

Hi-Clean™ pipe & tubing hangers

HI-CLEAN

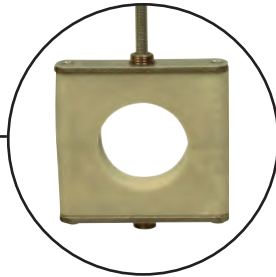
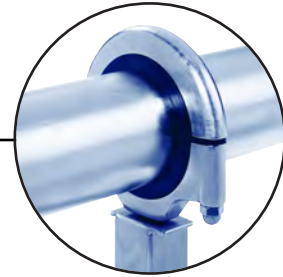
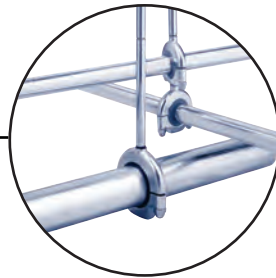
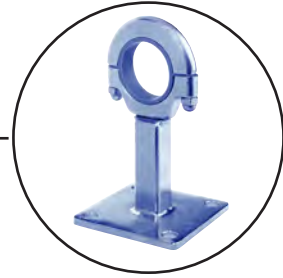
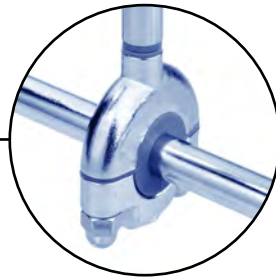

For clean work areas and clean rooms.

HI-CLEAN™ STAINLESS SERIES

Supports: For use with Process, Food and Pharmaceutical Applications

PATENT APPROVED



- Clamp design is patent approved.
- Type 316 stainless steel is standard. No corrosion or painting.
- All exposed metallic holder surfaces are 35 R_a or better.
- All non-metallic materials are FDA compliant.
- No exposed threaded pipe support components.
- Only closed sections such as round, square or rectangular tube steel are used with end caps which close the sections.
- Exposed threads or bolts and anchor bolts are concealed by locking acorn nuts.
- Edges and inside corners are chamfered or rounded for cleanliness and safety.
- Optional grommets allow for either tube or pipe “clamping” or “sliding”.

Pipe & Tubing Hanger follows the design principles of BPE-2002

BPE-2002 SECTION	HANGER DESIGN PRINCIPLE
SD-3.1.1	The hanger surfaces are rounded and cleanable.
SD-3.1.2	The use of horizontal surfaces is minimized.
SD-3.1.3	The hangers are drainable and free of surfaces where liquids could collect. The grommet around the tubing or piping is leak tight and the rounded surfaces of the assembly are conducive to spillage removal and drainage of periodic washdown fluids.
SD-3.1.5	The hanger surfaces are accessible to cleaning solutions.
SD-3.1.6	The hanger surfaces have no exposed threads. The use of acorn nuts covers the fastener threads.
SD-3.3.1	Hangers are supplied in a polished condition, if requested by the customer.
SD-3.4.1	Standard material of construction is 316 stainless and cast CF8M.
SD-3.4.2	The nitrile, silicone, and teflon grommet materials are compliant with 21CFR 177.
SD-3.7.6	Hanger surfaces are self draining and horizontal surfaces are minimized.
SD-3.8 (a)	Hanger surfaces are stainless steel or FDA compliant elastomers. There are no plating or coating that could chip or flake.
SD-3.8 (b)	Hanger finish is polished. Electro-polishing is also available.
SD-3.8 (c)	The hangers, and their gasketing and grommets, are suitable for washdown. The use of silicon for grommets and gasketing is compatible with steam cleaning.
SD-3.8 (d)	Burrs are removed as part of normal manufacturing operations

REFERENCE SPECIFICATIONS

MSS SP-69	Manufacturers Standardization Society Standard Practice: Pipe Hangers and Supports - Selection and Application.
MSS SP-77	Manufacturers Standardization Society Standard Practice: Guidelines for Pipe Support Contractual Relationships - Relationships and Responsibilities of the Pipe Hanger Contractor with the Purchaser's Engineer or the Pipe Fabricator and/or Erector
MSS SP-89	Pipe Hangers and Supports - Fabrication and Installation Practices.

Hi-Clean Clamps Maximum Load in Pipe Direction (F1) Hanging Load Rating for Hang Plate / Swivel Plate Assemblies (F2)

HI-CLEAN SERIES

STAUFF Group	Hexagon Hex Bolt (AS)	Polypropylene				Santoprene							
		Tightening Torque [Nm] Ft/Lb		Max Load in Pipe Direction [kN] Lbs.		Tightening Torque [Nm] Ft/Lb		Max Load in Pipe Direction [kN] Lbs.					
3	1/4"-20UNC	8	6	0.35	79	1.6	354	8	6	0.13	29	1.6	354
6	1/4"-20UNC	8	6	0.31	70	1.3	298	8	6	0.13	29	1.3	298
7L	1/4"-20UNC	8	6	0.3	67	1	219	8	6	0.13	29	1	219
8	1/4"-20UNC	8	6	0.25	56	0.6	137	8	6	0.18	40	0.6	137
9L	1/4"-20UNC	12	9	0.24	54	0.5	110	12	9	0.2	45	0.5	110

Safety Factor for Hanging Loads is a 4:1 Ratio.
Due to Flow Behavior in Santoprene, it is recommended to use Locktite on Hexagon Hex Bolt (AS) threads in conjunction with the Tightening Torque.

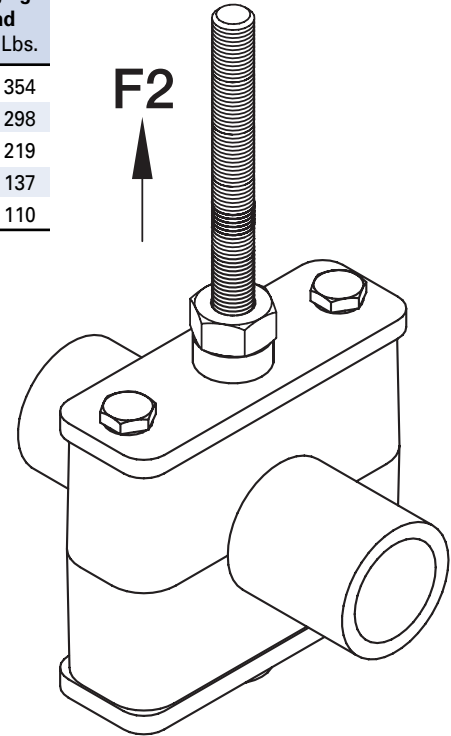
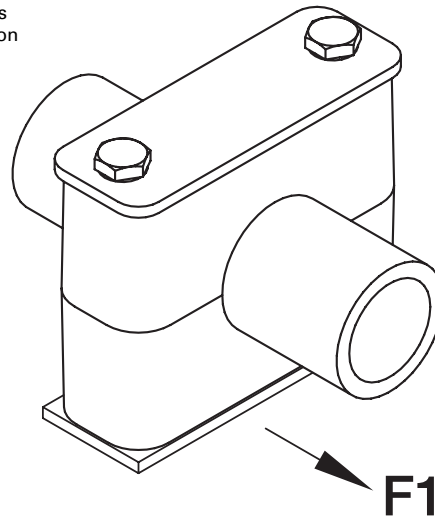

Technical Notes

Properties of Clamp Body Materials

MATERIAL PROPERTIES	POLYPROPYLENE PP Color: Blue	SANTOPRENE SA Color: Natural
MECHANICAL PROPERTIES		
Flexural Deflection	36 N/mm ²	
Impact Resistance	no failure	
Compressive Strength	Hardness: 66 Shore D	Hardness: 50 Shore D
Modulus of Elasticity	1073 N/mm ²	10 N/mm ²
Tensile Stress	25 N/mm ²	27.6 N/mm ²
THERMAL PROPERTIES		
Maximum Temperature	-22° to +215° F	-40° to +425° F
- Brief Exposure	-30° to +102° C	-40° to +218° C
Operating Temperature	-22° to +194° F	-40° to +210° F
- Continuous Exposure	-30° to +90° C	-40° to +99° C
CHEMICAL PROPERTIES		
Weak Acids, Solvents	conditionally consistent	conditionally consistent
Benzine, Mineral Oils	conditionally consistent	conditionally consistent
Alcohol, Other Oils, Seawater	consistent	consistent

Contact factory for further information.

Hanger Holding Assembly

COMPONENT	MATERIAL	SPECIFICATION	STANDARD FINISH
Holder Housing, Upper & Lower	316 stainless steel	Casting grade CF8M	35 Ra
Holder Grommet	Silicone (blue)	70 shore A	--
Slider Grommet	PTFE	50-65 shore D	--
Acorn Nuts, Locking	18-8 stainless steel		--
Mounting Stud	18-8 stainless steel		Threaded (not exposed)

PTFE grommet is bored to allow pipe/tube to slide.

Note: Other materials available on request. Consult factory for details.

Hanger Support Assembly

COMPONENT	MATERIAL	SPECIFICATION	STANDARD FINISH
Top Mount Support Rod	316 series stainless		50 Ra Mill
Bottom Mount Base Plate	316 series stainless	Casting grade CF8M	35 Ra
Bottom Assembly Rod	316 series stainless		50 Ra Mill
Square Telescoping Tubing	316 series stainless		35 Ra
Square Stand Off	316 series stainless	Casting grade CF8M	35 Ra
Wall Mount Bracket	316 series stainless	Casting grade CF8M	35 Ra
Wall Mount Tube	316 series stainless		35 Ra
Round Stand Off	316 series stainless	Casting grade CF8M	35 Ra
Wall Mount Tube Cap	PVC vinyl		--
Multiple Run Connector	316 series stainless		Threaded (not exposed)
Top Mount Support Rod Coned Gasket	Silicone	70 durometer hardness	As molded

Note: Other materials available on request. Consult factory for details.

Top Mount Support Rod Dimensions

PIPE / TUBING SIZE	ROD DIAMETER	TAP DIAMETER
1/4" tube - 2" tube	3/8"	3/8" - 16 UNC
2" pipe - 3" pipe	1/2"	1/2" - 13 UNC
4" pipe and tube	5/8"	5/8" - 11 UNC
6" pipe and tube	3/4"	3/4" - 10 UNC

Top Mount Support Rods come in 6", 12", and 24" Standard Lengths.

Grommet Material Ratings

MATERIAL	TYPE	TEMP. RATING	
Silicone	Clamp	400°F	204°C
PTFE	Slide	400°F	204°C

Note: Other materials available on request. Consult factory for details.

Sizing Pipe and Tubing Hanger Grommets

SIZE	PIPE O.D.	TUBE O.D.	COPPER TUBE O.D.*
1/4"	0.54"	0.25"	0.375"
3/8"	0.68"	0.37"	0.500"
1/2"	0.84"	0.5"	0.625"
3/4"	1.05"	0.75"	0.875"
1"	1.32"	1.0"	1.125"
1-1/4"	1.66"	1.25"	1.375"
1-1/2"	1.90"	1.5"	1.625"
2"	2.38"	2.0"	2.125"
2-1/2"	2.88"	2.5"	2.625"
3"	3.5"	3.0"	3.125"
4"	4.5"	4.0"	4.125"
6"	6.63"	6.0"	6.125"

Important Note: Be sure to specify appropriate hanger sizes for pipe or tube. Industry trade standards for measuring pipe and tube outside diameter (O.D.) is shown in the chart above. Use a calliper to measure pipe/tube to ensure proper grommet size.

Hanger Assembly

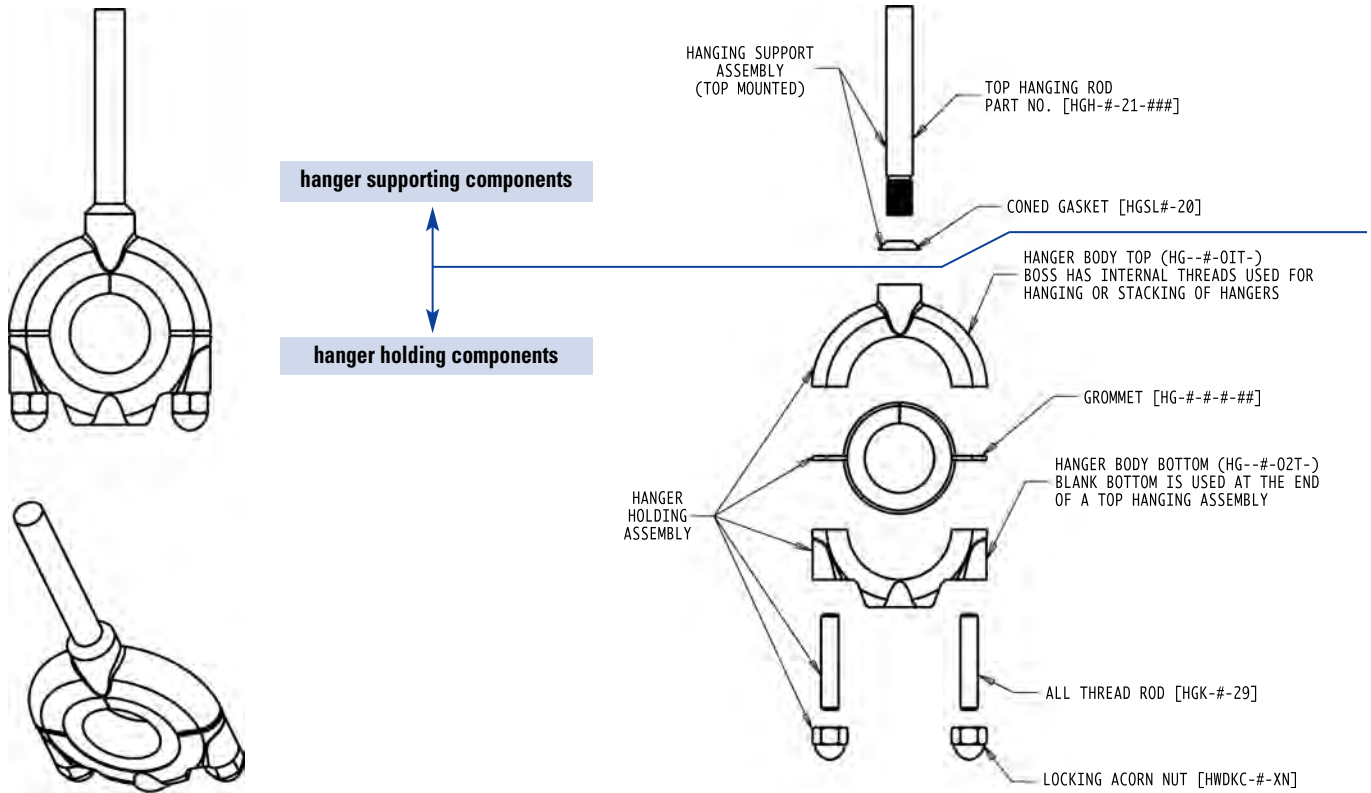

Bottom Mount Assembly

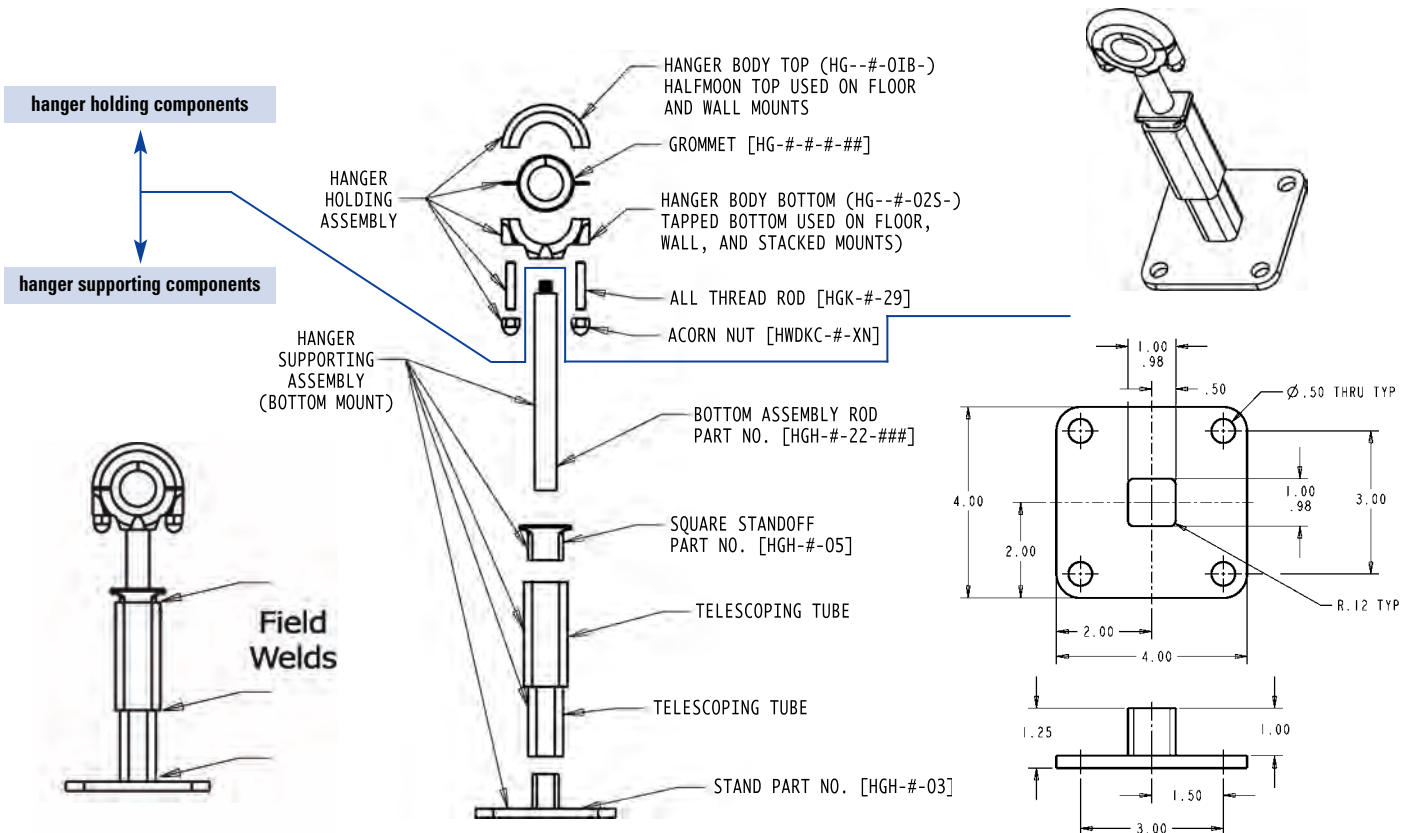

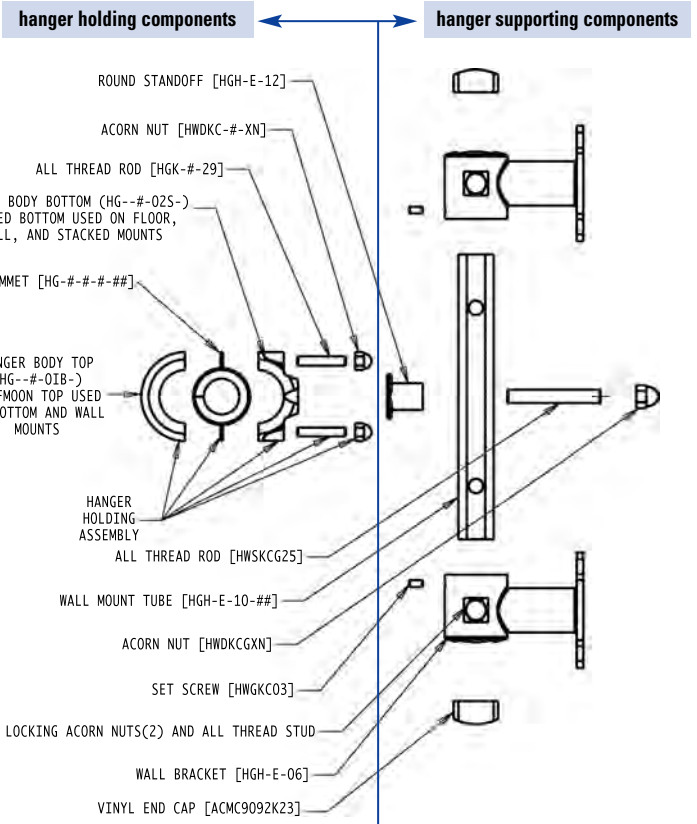
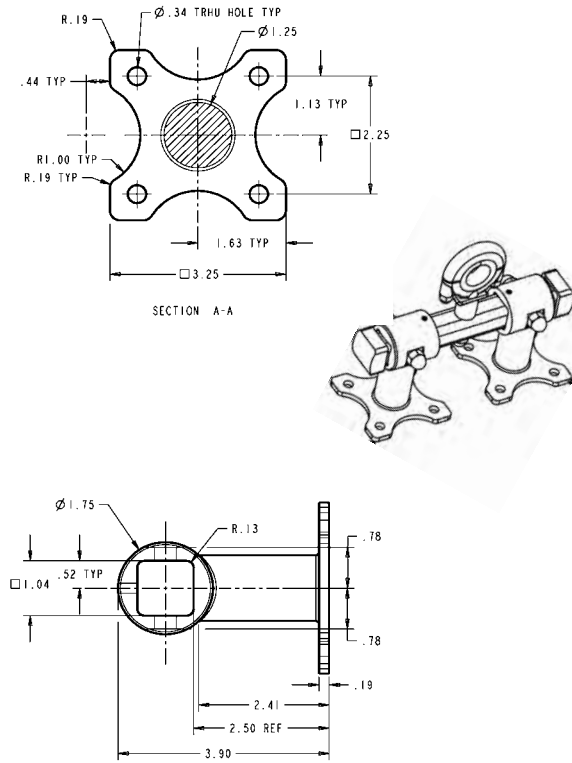

Multi-Hanger Holding Assemblies

Top Mounted Multi-Hanger

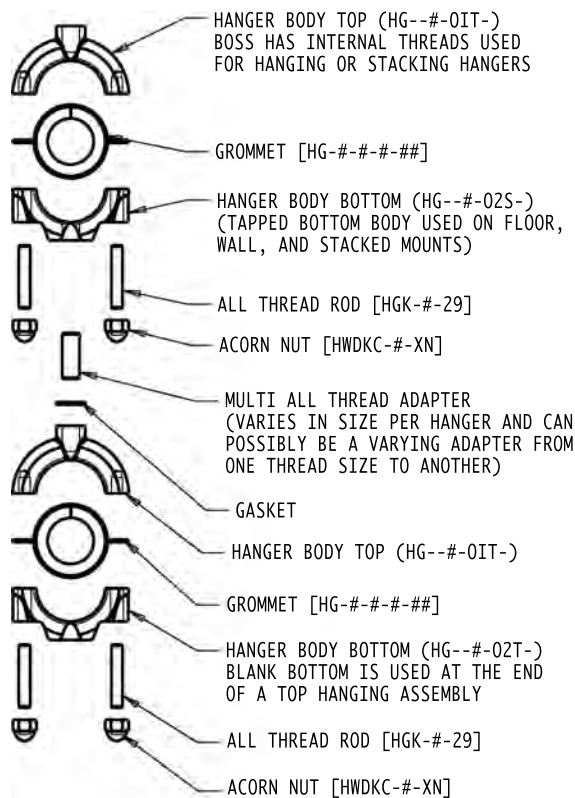

Bottom or Wall Mounted Multi-Hanger

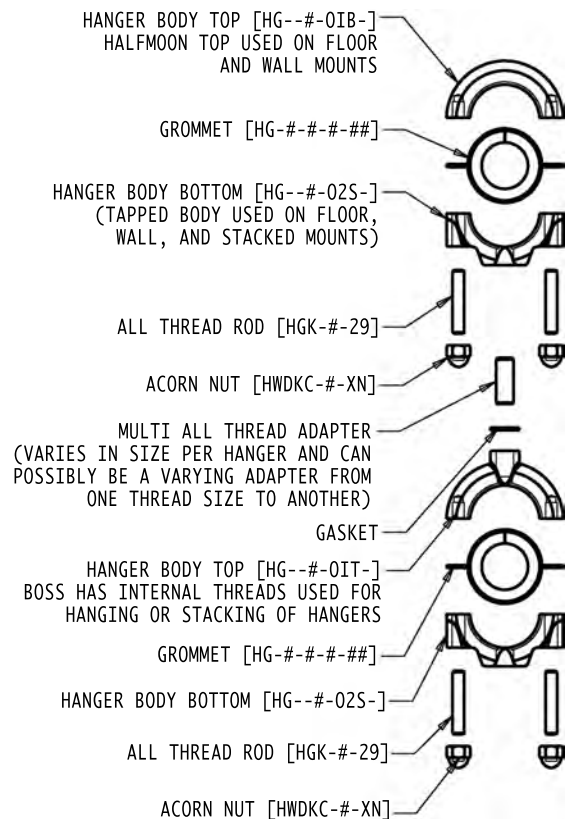

Top Mount (Hang from Ceiling) Housing Dimensions

GROMMET SIZE*		DIMENSIONS								APPROX. WEIGHT
PIPE	TUBE	UNITS	B	C	D	E	F	G	H	
1/4", 3/8" 1/2"	1/4", 3/8"	inches	2.22	1.25	2.02	0.63	1/4"-20	3/8"-16	.94	0.32 lbs
	1/2", 3/4"	mm	56.39	31.7	51.3	16.00			23.88	0.145 kg
3/4", 1"	1", 1-1/4"	inches	2.72	1.50	2.52	0.63	1/4"-20	3/8"-16	1.15	0.44 lbs
		mm	69.08	38.1	64.0	16.00			29.21	0.2 kg
1-1/4" 1-1/2"	1-1/2"	inches	3.50	1.88	3.62	0.75	5/16"-18	3/8"-16	1.62	0.95 lbs
	2"	mm	88.9	47.75	91.95	19.10			41.15	0.43 kg
2", 2-1/2" 3"	2-1/2"	inches	5.07	2.63	5.25	0.88	5/16"-18	1/2"-13	2.44	1.97 lbs
	3"	mm	128.8	66.80	133.4	22.4			61.98	0.89 kg
4"	4"	inches	6.62	3.50	6.75	1.00	3/8"-16	5/8"-11	3.12	3.35 lbs
		mm	168.1	88.90	171.5	25.40			79.25	1.52 kg
6"	6"	inches	8.88	4.50	9.00	1.25	1/2"-13	3/4"-10	4.38	7.41 lbs
		mm	225.6	114.3	228.6	31.75			111.25	3.36 kg

Bottom/Wall Mount (Mount from floor to wall) Housing Dimensions

GROMMET SIZE*		DIMENSIONS								APPROX. WEIGHT
PIPE	TUBE	UNITS	B	C	D	E	F	G	H	
1/4", 3/8" 1/2"	1/4", 3/8"	inches	1.98	1.01	2.02	0.63	1/4"-20	3/8"-16	.94	0.31 lbs
	1/2", 3/4"	mm	50.30	25.60	51.3	16.0			23.88	0.14 kg
3/4", 1"	1", 1-1/4"	inches	2.48	1.26	2.52	0.63	1/4"-20	3/8"-16	1.15	0.44 lbs
		mm	63.00	32.00	64.0	16.0			29.21	0.2 kg
1-1/4" 1-1/2"	1-1/2"	inches	3.43	1.81	3.62	0.75	5/16"-18	3/8"-16	1.62	0.96 lbs
	2"	mm	87.1	46.00	91.95	19.1			41.15	0.44 kg
2", 2-1/2" 3"	2-1/2"	inches	5.07	2.63	5.25	0.88	5/16"-18	1/2"-13	2.44	1.99 lbs
	3"	mm	128.8	66.8	133.4	22.4			61.9	0.90 kg
4"	4"	inches	6.50	3.38	6.75	1	3/8"-16	5/8"-11	3.12	3.38 lbs
		mm	165.1	85.80	171.5	25.4			79.25	1.53 kg
6"	6"	inches	8.88	4.50	9.00	1.25	1/2"-13	3/4"-10	4.38	7.36 lbs
		mm	225.6	114.3	228.6	31.75			111.25	3.33 kg

Multiple-Run (Stacking) Housing Dimensions

GROMMET SIZE*		DIMENSIONS								APPROX. WEIGHT
PIPE	TUBE	UNITS	B	C	D	E	F	G	H	
1/4", 3/8" 1/2"	1/4", 3/8"	inches	2.22	1.25	2.02	0.63	1/4"-20	3/8"-16	.94	0.32 lbs
	1/2", 3/4"	mm	56.39	31.75	51.3	16.0			23.88	0.145 kg
3/4", 1"	1", 1-1/4"	inches	2.72	1.5	2.52	0.63	1/4"-20	3/8"-16	1.15	0.44 lbs
		mm	69.08	38.1	64.0	16.0			29.21	0.2 kg
1-1/4" 1-1/2"	1-1/2"	inches	3.5	1.88	3.62	0.75	5/16"-18	3/8"-16	1.62	0.95 lbs
	2"	mm	88.9	47.75	91.95	19.1			41.15	0.43 kg
2", 2-1/2" 3"	2-1/2"	inches	5.07	2.63	5.25	0.88	5/16"-18	1/2"-13	2.44	1.97 lbs
	3"	mm	128.8	66.8	133.4	22.4			61.98	0.89 kg
4"	4"	inches	6.62	3.5	6.75	1	3/8"-16	5/8"-11	3.12	3.35 lbs
		mm	168.1	88.9	171.5	25.4			79.25	1.52 k
6"	6"	inches	8.88	4.50	9.00	1.25	1/2"-13	3/4"-10	4.38	7.41 lbs
		mm	225.6	114.3	228.6	31.75			111.25	3.36 kg

Top Mount (Hang from Ceiling)

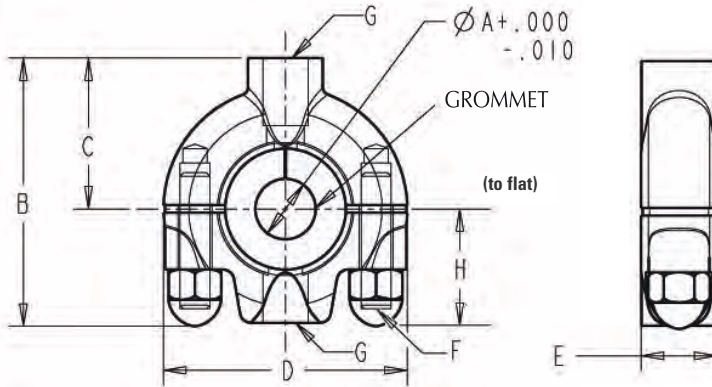

There are six different housing size codes that accommodate pipe and tube sizes from 1/4" - 6". The housing size codes are "C, E, H, K, L, and M". Dimensions of housing codes can be seen on tabulated drawings to the left.

LINE SIZE	HOUSING SIZE CODE		
	TUBING	PIPE	COPPER TUBE
1/4"	C	C	C
3/8"	C	C	C
1/2"	C	C *	C
3/4"	C	E	C
1"	E	E *	E
1-1/4"	E	H	E
1-1/2"	H	H	H
2"	H	K	H
2-1/2"	K	K	K
3"	K	K *	K
4"	L	L	L
6"	M	M	M

Bottom/Wall Mount (Mount from floor to wall)

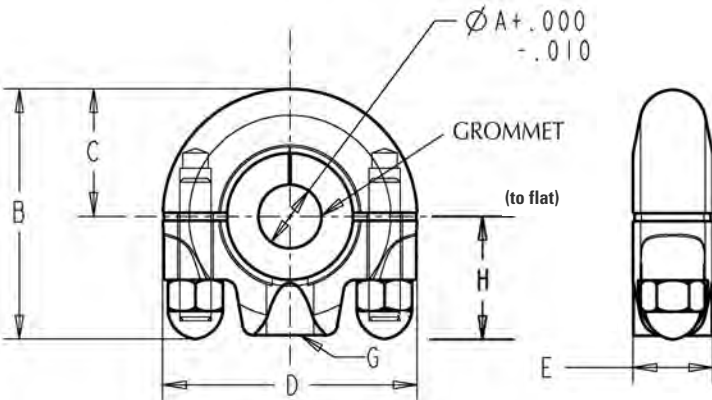

* Slider Housing moves up one size

Varying all-thread adapters are used to connect two (2) different hanger holder housing sizes. Use the chart above to determine if varying adapters are required.

For example, if you wish to hang a 1-1/2" tube holder from a 2" tube holder, since the housings are the same size (size code "H"), a standard all-thread adapter is required.

Multiple-Run (Stacking)

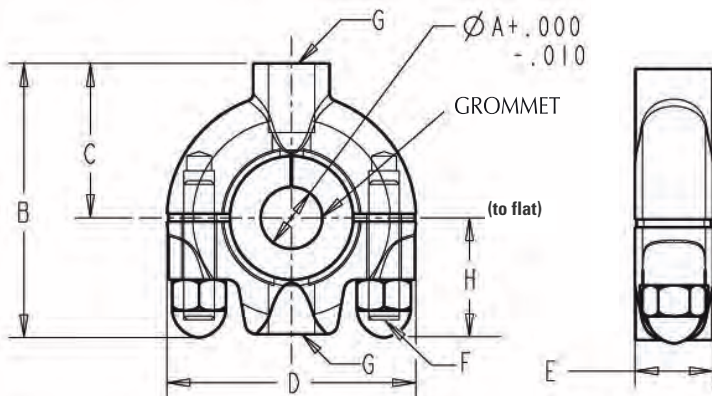

If you wish to hang a 1-1/2" tube holder from a 3" tube holder, the housings are different size codes (1-1/2" tube = code H, 3" tube = code K), therefore a varying all-thread adapter is required.

Box Quantities

SIZE RANGE	BOX QTY
1/4" tube - 1-1/4" tube	24
1-1/4" pipe - 2" tube	12
2" pipe - 4" pipe	6
6" tube/pipe	1

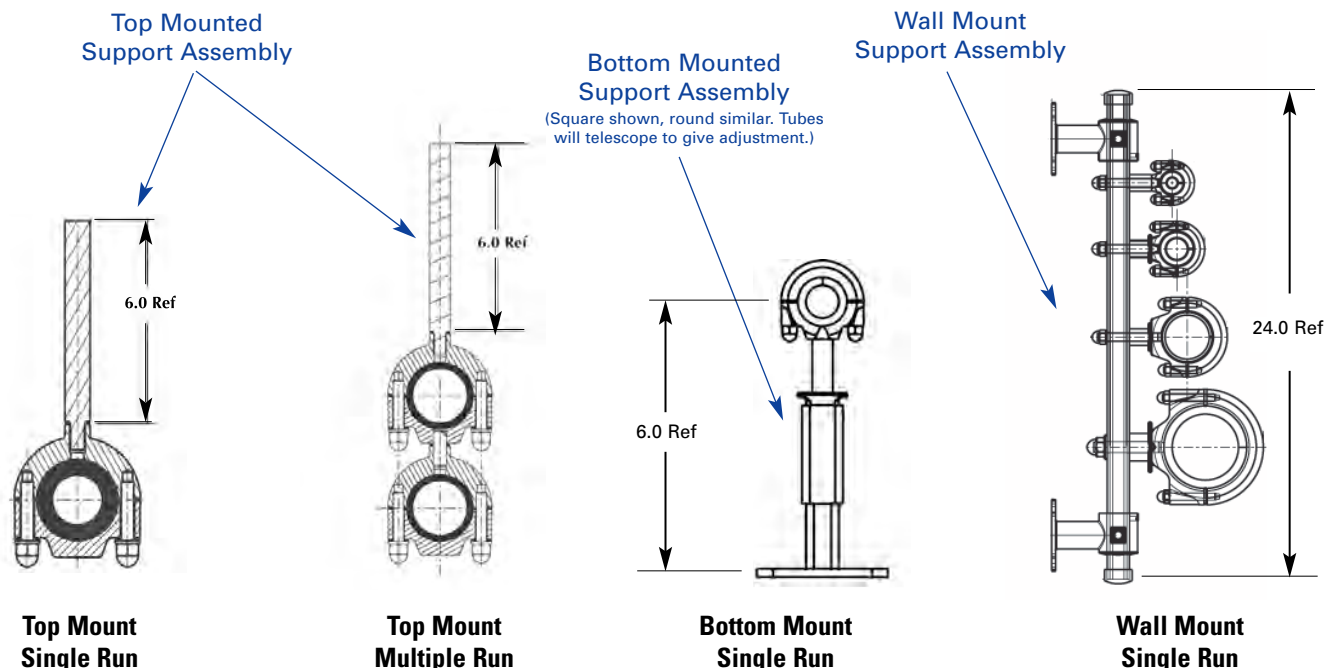

Pipe and Tubing Supports Ordering Information

Number in "()" represents part number position.

Product (1-2)		Material (3-4)		Size* (5)		Hanger Style (6)		Grommet Style (7)		Grommet Material (8-9)		Hanger Type (10)		Polish Option (11-12)	
HH	Hanger Holding Assembly	H-	316 Stainless	A	1/4"	T	Top Mounted from Ceiling	F	Tube Diameter	SL	Silicone, 70 Durometer	S	Single Run (1 Tapped Hole)	--	35 R _a Finish (Standard)
				B	3/8"			A-	20 R _a Mirror Finish						
				C	1/2"			B	Bottom or Wall Mount					T	Copper Tube Diam.
				D	3/4"	AM	20 R _a Mirror Finish + Electro Polish								
				E	1"										
				F	1.25"										
				G	1.5"										
				H	2"										
				J	2.5"										
				K	3"										
				L	4"										
M	6"														

Ordering Example

Series	Material	Size	Hanger Style	Grommet Style	Grommet Material	Hanger Type	Polish Option
HH	H-	C	T	F	SL	S	--
Hanger Holding Assembly	316 Stainless Steel	1/2" size	Top Mount from Ceiling	Tube Diameter	Silicone, 70 Durometer	Single Run	35 R _a Finish

Pipe and Tubing Support Rods and Components Ordering Information

Number in "()" represents part number position.

Product (1-2)		Material (3-4)		Size (5)		Hanger Style (6)		Length (7-9)		Polish Options (10-11)	
HS	Hanger Supporting Assembly	H-	316 Stainless Steel	A	1/4" thru 3/8"	T	Top Mounted from Ceiling	XYZ	X = Feet; YZ - Inches	--	50 R _a Finish (Standard)
				D	1/2" thru 2" Tube						B
				H	2" Pipe thru 3"	-M	50 R _a Finish + Electro Polish				
				L	4" Pipe and Tube	W	Wall Mount	110	1'10" (base mount adjustable from 1'10" to 3'6")	AM	
				M	6" Pipe and Tube						

Ordering Example

Series	Material	Size	Hanger Style	Length	Polish Option
HS	H-	D	T	006	A-
Hanger Support Assembly	316 Stainless Steel	1/2" thru 2" Tube	Top Mount from Ceiling	6"	Mechanically Polished to 20 R _a Mirror Finish

Sizing DIN and ISO Hanger Grommets

SIZE	ISO 4200 O.D.	DIN 11850 O.D.
8 (1/4")	13.50 (.531")	10.00 (.394")
10 (3/8")	17.20 (.677")	12.00 (.472")
15 (1/2")	21.30 (.839")	19.00 (.748")
20 (3/4")	26.90 (1.059")	23.00 (.906")
25 (1")	33.70 (1.327")	29.00 (1.142")
32 (1-1/4")	42.40 (1.669")	35.00 (1.378")
40 (1-1/2")	48.30 (1.902")	41.00 (1.614")
50 (2")	60.30 (2.374")	53.00 (2.087")
65 (2-1/2")	76.10 (2.996")	70.00 (2.756")
80 (3")	88.90 (3.50")	85.00 (3.347")
100 (4")	114.30 (4.50")	104.00 (4.094")
150 (6")	154.00 (6.063")	154.00 (6.063")

Important Note: Be sure to specify appropriate hanger sizes for pipe or tube. Industry trade standards for measuring pipe and tube outside diameter (O.D.) is shown in the chart above. Use a calliper to measure pipe/tube to ensure proper grommet size.

Pipe and Tubing Supports Ordering Information

Number in "()" represents part number position.

Product (1-2)	Material (3-4)	Size (5)	Hanger Style (6)	Grommet Style (7)	Grommet Material (8-9)	Hanger Type (10)	Polish Option (11-12)
HH Hanger Holding Assembly	H- 316 Stainless	A 8 (1/4")	T Top Mounted from Ceiling	D DIN 11850 Diam.	SL Silicone, 70 Durometer	S Single Run (1 Tapped Hole)	-- 35 R _a Finish (Standard)
		B 10 (3/8")					I ISO 4200 Diam.
		C 15 (1/2")	B Bottom or Wall Mount	VT Teflon (Slider)	M Multiple Run (2 Tapped Holes)	-M 35 R _a Finish + Electro Polish	
		D 20 (3/4")				AM 20 R _a Mirror Finish + Electro Polish	
		E 25 (1")					
		F 32 (1.25")					
		G 40 (1.5")					
		H 50 (2")					
		J 65 (2.5")					
		K 80 (3")					
		L 100 (4")					
		M 150 (6")					

Ordering Example

Series	Material	Size	Hanger Style	Grommet Style	Grommet Material	Hanger Type	Polish Option
HH	H-	C	T	D	SL	S	- -
Hanger Holding Assembly	316 Stainless Steel	15 (1/2") size	Top Mount from Ceiling	DIN 11850 Diam.	Silicone, 70 Durometer	Single Run	35 R _a Finish

Pipe and Tubing Support Rods and Components Ordering Information

Number in "()" represents part number position.

Product (1-2)	Material (3-4)	Size (5)	Hanger Style (6)	Length (7-9)	Polish Options (10-11)
HS Hanger Supporting Assembly	H- 316 Stainless Steel	A 8 thru 10	T Top Mounted from Ceiling	XYZ X = Feet; YZ - Inches	-- 50 R _a Finish (Standard)
		D 15 thru DN 50	B Bottom Mount from Floor (Square Tube)		A- 20 R _a Mirror Finish
		H ISO 50 thru 80		W Wall Mount	006 6" (base mount adjustable from 6" to 10")
		L 100 DIN + ISO	AM 20 R _a Mirror Finish + Electro Polish		
		M 150 DIN + ISO	110 1'10" (base mount adjustable from 1'10" to 3'6")		

Ordering Example

Series	Material	Size	Hanger Style	Length	Polish Option
HS	H-	D	T	006	A-
Hanger Support Assembly	316 Stainless Steel	15 thru DN 50	Top Mount from Ceiling	6"	Mechanically Polished to 20 R _a Mirror Finish



Housing

HOUSING SIZE	SIZE	HANGER BODY TOP	HANGER BODY BOTTOM, UNTAPPED	"HALFMOON" BODY TOP	HANGER BODY BOTTOM, TAPPED
C	1/4" thru 3/4"	HGH-C-01T-	HGH-C-02T-	HGH-C-01B-	HGH-C-02S-
E	3/4" thru 1-1/4"	HGH-E-01T-	HGH-E-02T-	HGH-E-01B-	HGH-E-02S-
H	1-1/4" thru 2"	HGH-H-01T-	HGH-H-02T-	HGH-H-01B-	HGH-H-02S-
K	2" thru 3"	HGH-K-01T-	HGH-K-02T-	HGH-K-01B-	HGH-K-02S-
L	4"	HGH-L-01T-	HGH-L-02T-	HGH-L-01B-	HGH-L-02S-
M	6"	HGH-M-01T-	HGH-M-02T-	HGH-M-01B-	HGH-M-02S-

The Hanger Body Top is used for the Top Hanger Assembly. The Hanger Body Bottom, Untapped is used for the Top Hanger Assembly. The "Halfmoon" Body Top is used for the Bottom Mount Assembly and Wall Mount Assembly. The Hanger Body Bottom, Tapped is used for the Bottom Mount Assembly, and Multi-Mount Assembly.

Standard Material for Housings is T316 Stainless Steel. Standard Surface Finish is 35 Ra. Other Materials are available. Please Consult Factory for details.

Grommet

GROMMET SIZE	SIZE	TUBE PART NUMBER	PIPE PART NUMBER	COPPER TUBE PART NUMBER
C	1/4"	HGSLAF23	HGSLAB08	HGSLAT23
	3/8"	HGSLBF23	HGSLBB08	HGSLBT08
	1/2"	HGSLCF08	HGSLCB08	HGSLCT08
	3/4"	HGSLDF08		HGSLDT08
E	3/4"		HGSLDB08	
	1"	HGSLEF08	HGSLEB08	HGSLET08
	1-1/4"	HGSLFF08		HGSLFT08
H	1-1/4"		HGSLFB08	
	1-1/2"	HGSLGF08	HGSLGB08	HGSLGT08
	2"	HGSLHF08		HGSLHT08
K	2"		HGSLHB08	
	2-1/2"	HGSLJF08	HGSLJB08	HGSLJT08
	3"	HGSLKF08	HGSLKB08	HGSLKT08
L	4"	HGSLLF08	HGSLLB08	HGSLLT08
M	6"	HGSLMF08	HGSLMB08	HGSLMT08

Standard Material for Grommets is Silicone, 70 Durometer. Other Materials are available. Please Consult Factory for details.

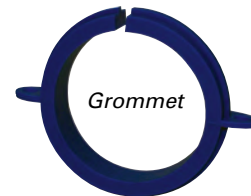

Grommet



All Threaded Rod

HOUSING SIZE	ALL THREADED ROD PART NUMBER
C	HGK-C-29
E	HGK-E-29
H	HGK-H-29
K	HGK-K-29
L	HGK-L-29
M	HGK-M-29

Standard Material for All Thread Rod is 18-8 Stainless Steel.

Slider Grommet

GROMMET SIZE	SIZE	TUBE PART NUMBER	PIPE PART NUMBER	COPPER TUBE PART NUMBER
C	1/4"	HGVTAF24	HGVTAB24	HGVTAT24
	3/8"	HGVTBF24	HGVTBB24	HGVTBT24
	1/2"	HGVTCF24	HGVTCB24	HGVTCT24
	3/4"	HGVTDF24		HGVTDT24
E	3/4"		HGVTDB24	
	1"	HGVTEF24	HGVTEB24	HGVTET24
	1-1/4"	HGVTEF24		HGVTFT24
H	1-1/4"		HGVTFB24	
	1-1/2"	HGVTFG24	HGVTFB24	HGVTFG24
	2"	HGVTHF24		HGVTHF24
K	2"		HGVTHB24	
	2-1/2"	HGVTFJ24	HGVTFB24	HGVTFJ24
	3"	HGVTKF24	HGVTKB24	HGVTKT24
L	4"	HGVTLF24	HGVTLB24	HGVTLT24
M	6"	HGVTMF24	HGVTMB24	HGVMTT24

Standard Material for Slider Grommets is Teflon. Other Materials are available. Please Consult Factory for details.



Acorn Nut

HOUSING SIZE	ACORN NUT PART NUMBER
C	HWDKCEXN
E	HWDKCEXN
H	HWDKCFXN
K	HWDKCFXN
L	HWDKCGXN
M	HWDKCIXN

Standard Material for Acorn Nut is 18-8 Stainless Steel.



Slider Grommet

HI-CLEAN™ PLASTIC SERIES

Supports: For use with Process, Food and Pharmaceutical Applications

Specifications

- Smooth Clamping Surface for Sanitary, Clean in Place (CIP) Installations
- Body Material
 - Polypropylene (PP-Blue)
 - Santoprene (SA-Natural)
 - UHMW (special order)
- Support Hardware
 - 304 Stainless Steel
 - 316 Stainless Steel (special order)
 - Zinc Plated Carbon Steel (special order)
- Modular Design for Multiple Mounting Configurations
- Santoprene (SA) is FDA Approved
- Hardware Compatible with Standard Series Clamps



Hi-Clean Support Bodies

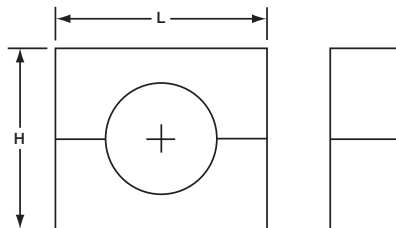

GRP	SIZE	O. D.	H	L	POLYPROPYLENE	SANTOPRENE
3	1/4" T	0.25"	1.40"	1.96"	3064 PPC	3064 SAC
	3/8" T	0.375"			3095 PPC	3095 SAC
	1/2" T	0.50"			3127 PPC	3127 SAC
	3/4" T	0.75"			3190 PPC	3190 SAC
	1/2" P	0.84"			3213 PPC	3213 SAC
	1" T	1.00"			3254 PPC	3254 SAC
6	1/4" T	0.25"	2.53"	3.38"	6064 PPC	6064 SAC
	1/2" T	0.50"			6127 PPC	6127 SAC
	5/8" T	0.625"			6160 PPC	6160 SAC
	3/4" T	0.75"			6190 PPC	6190 SAC
	1/2" P	0.84"			6213 PPC	6213 SAC
	7/8" T	0.875"			6222 PPC	3222 SAC
	1" T	1.00"			6254 PPC	6254 SAC
	3/4" P	1.05"			6266 PPC	6266 SAC
	1" P	1.315"			6334 PPC	6334 SAC
	1 1/2" T	1.50"			6381 PPC	6381 SAC
	1 1/2" P	1.90"			6483 PPC	6483 SAC
	2" T	2.00"			6508 PPC	6508 SAC
	7L	2" T			2.00"	4.26"
2" P		2.375"	7603 LPPC	7603 LSAC		
2 1/2" T		2.50"	7635 LPPC	7635 LSAC		
2 1/2" P		2.875"	7730 LPPC	7730 LSAC		
3" T		3.00"	7762 LPPC	7762 LSAC		
8L	4" T	4.00"	4.56"	5.75"	8102 LPPC	8102 LSAC
9L	6" T	6.00"	7.52"	8.85"	9152 LPPC	9152 LSAC

P = Pipe T = Tube

Other sizes and materials available on request.

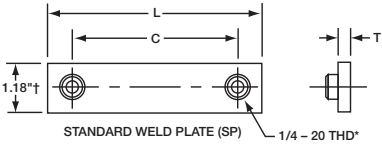
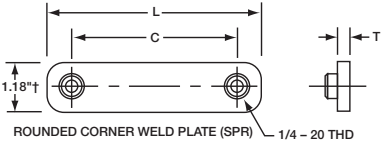
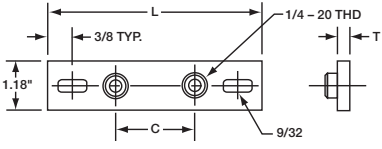
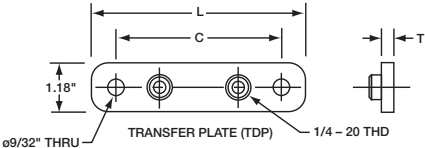
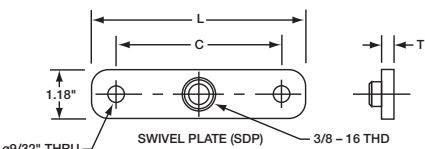
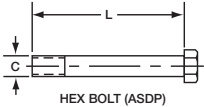
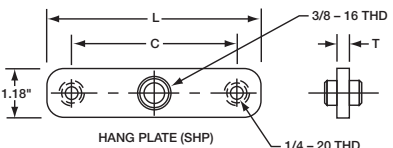
	GROUP	PART #	DIMENSIONS		
			L	C	T
STANDARD WELD PLATE (SP) * SP9L has 3/8-16 UNC Thread † SP9L width is 1.38"  For Weld in Place Use	3	SP3-UW4	1.97"	1.30"	0.11"
	6	SP6-UW4	3.48"	2.60"	0.11"
	7L	SP7L-UW4	5.00"	4.25"	0.11"
	8	SP8-UW4	5.75"	4.72"	0.19"
	9L	SP9L-UW4	8.75"	7.67"	0.31"
ROUNDED CORNER WELD PLATE (SPR) * SPR9L has 3/8-16 UNC Thread † SPR9L width is 1.38"  For Suspension Use	3	SPR3-UW4	1.97"	1.30"	0.11"
	6	SPR6-UW4	3.48"	2.60"	0.11"
	7L	SPR7L-UW4	5.00"	4.25"	0.11"
	8	SPR8-UW4	5.75"	4.72"	0.19"
	9L	*	*	*	*
BASE PLATE (SPV)  For Bolt or Weld in Place	3	SPV3-UW4	3.07"	1.30"	0.11"
	6	SPV6-UW4	4.52"	2.60"	0.11"
	7L	SPV7L-UW4	6.50"	4.25"	0.11"
	8	*	—	—	—
	9L	*	—	—	—
TRANSFER PLATE (TDP) * TDP9L has ø7/16" THRU  For Stacking Different Clamp Groups	3/6	TDP3-UW4	3.38"	2.60"	0.11"
	6/7	TDP6-UW4	5.00"	4.25"	0.11"
	7L/3	TDP7L-UW4	5.00"	4.25"	0.11"
	8	*	—	—	—
	9L	*	—	—	—
SWIVEL PLATE (SDP) * SDP9L has ø7/16" THRU  For Hanging	3	SDP3-UW4	1.89"	1.30"	0.20"
	6	SDP6-UW4	3.38"	2.60"	0.20"
	7L	SDP7L-UW4	5.00"	4.25"	0.20"
	8	SDP8-UW4	5.75"	4.72"	0.25"
	9L	*	—	—	—
HEX BOLT (ASDP)  For Hanging	3	AS3-UW4	1.50"	1/4"-20 UNC	—
	6	AS6-UW4	2.75"	1/4"-20 UNC	—
	7L	AS7L-UW4	4.375"	1/4"-20 UNC	—
	8	AS8-UW4	4.875"	1/4"-20 UNC	—
	9L	AS9L-UW4	8.00"	3/8"-16 UNC	—
HANG PLATE (SHP)  For Hanging	3	SHP3-UW4	1.95"	1.30"	0.20"
	6	SHP6-UW4	3.38"	2.60"	0.20"
	7L	SHP7L-UW4	5.00"	4.25"	0.20"
	8	SHP8-UW4	5.75"	4.72"	0.25"
	9L	*	—	—	—

* Consult factory

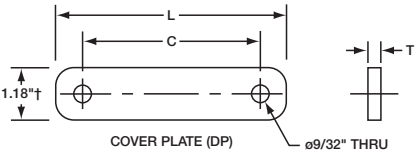
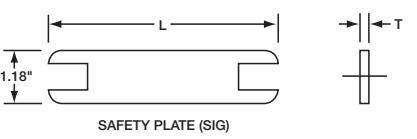
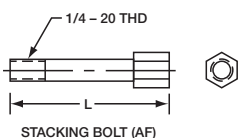
	GROUP	PART #	DIMENSIONS		
			L	C	T
COVER PLATE (DP) * DP9L has $\varnothing 7/16"$ THRU † DP9L width is 1.38" 	3	DP3-W4	1.89"	1.30"	0.11"
	6	DP6-W4	3.38"	2.60"	0.11"
	7L	DP7L-W4	5.00"	4.25"	0.11"
	8	DP8-W4	5.67"	4.72"	0.19"
	9L	DP9L-W4	8.75"	7.67"	0.16"
SAFETY PLATE (SIG) 	3	SIG3-W4	1.85"	—	0.03"
	6	SIG6-W4	3.34"	—	0.03"
	7L	SIG7L-W4	5.00"	—	0.03"
	8	*	—	—	0.03"
	9L	*	—	—	—
STACKING BOLT (AF) 	3	AF3-UW4	1.73"	—	—
	6	AF6-UW4	2.91"	—	—
	7L	AF7L-UW4	4.57"	—	—
	8	*	—	—	—
	9L	*	—	—	—

* Consult factory

Accessories for Hi-Clean Support Installation

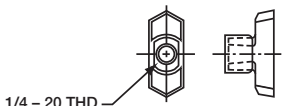
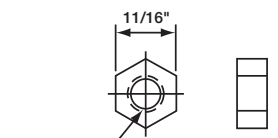
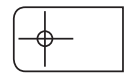
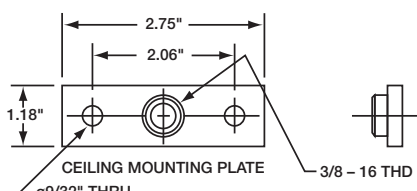
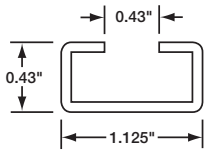
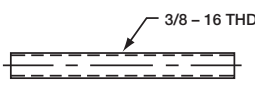
 <p>1/4 - 20 THD</p> <p>HEXAGON RAIL NUT</p> <p>PART#: SM1-8/1D-UW4 * Group 3-8 only</p>	 <p>11/16"</p> <p>3/8 - 16 THD</p> <p>HEX LOCK NUT</p> <p>PART#: SLN-UW4</p>	 <p>CLAMP SPACER (SEG) PART#: SEG-X-SAC-XXX STAUFF GROUP TUBE / PIPE-O.D.</p> <p>Use For "Sliding" Installations</p>
 <p>2.75"</p> <p>2.06"</p> <p>1.18"</p> <p>9/32" THRU</p> <p>CEILING MOUNTING PLATE</p> <p>3/8 - 16 THD</p> <p>PART#: SCP-UW4</p>	 <p>0.43"</p> <p>0.43"</p> <p>1.125"</p> <p>STANDARD LENGTH: 3/3' OR 6.6'</p> <p>MOUNTING RAIL</p> <p>PART#: TS11-1-W4 (3.3') PART#: TS11-2-W4 (6.6')</p>	 <p>3/8 - 16 THD</p> <p>THREADED ROD</p> <p>STANDARD LENGTH 6 FT SPECIAL LENGTHS MADE TO ORDER</p> <p>PART#: THR-6-UW4</p>

Hi-Clean Assembly Hang Plate / Cover Plate Style

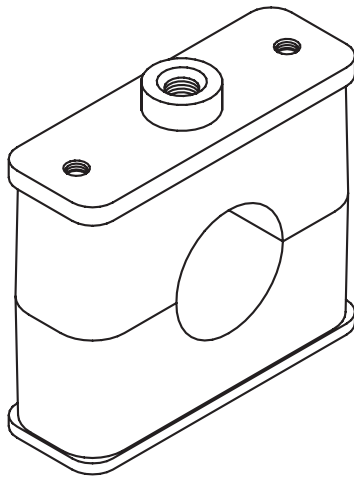
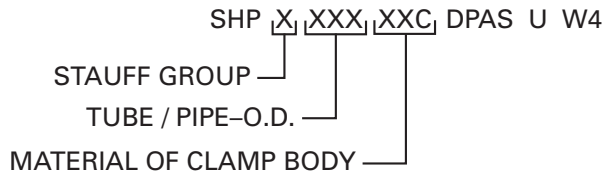

- Clamp Consisting of:**
- 1x Hang Plate
 - 1x Clamp Body (2 Halves)
 - 1x Cover Plate
 - 2x Hex Head Bolt

Hi-Clean Assembly Hang Plate / Swivel Plate Style

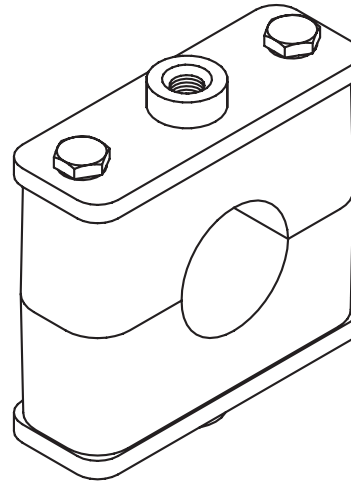
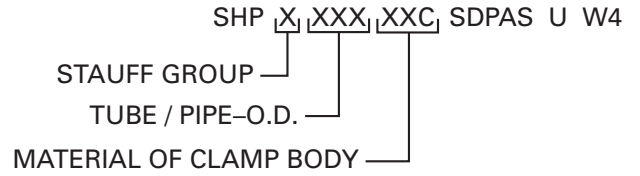

- Clamp Consisting of:**
- 1x Hang Plate
 - 1x Clamp Body (2 Halves)
 - 1x Swivel Plate
 - 2x Hex Head Bolt

Hi-Clean Assembly Rounded Weld Plate / Swivel Plate Style

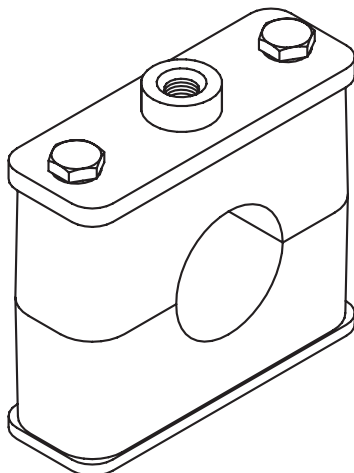
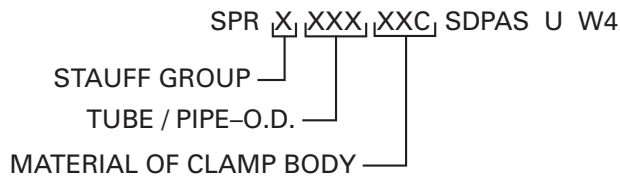

- Clamp Consisting of:**
- 1x Rounded Weld Plate
 - 1x Clamp Body (2 Halves)
 - 1x Swivel Plate
 - 2x Hex Head Bolt

Hi-Clean Assembly Weld Plate / Cover Plate Style

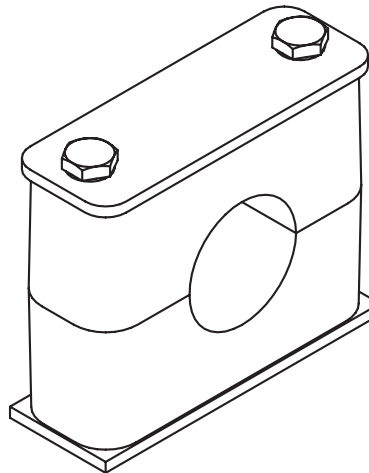
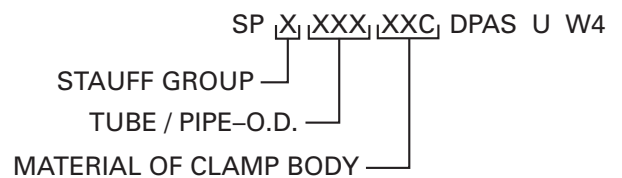

- Clamp Consisting of:**
- 1x Weld Plate
 - 1x Clamp Body (2 Halves)
 - 1x Cover Plate
 - 2x Hex Head Bolt



AUSTRALIA

STAUFF Corporation Pty. Ltd.
P. O. Box 227
Unanderra Wollongong, NSW, 2526
24-26 Doyle Avenue
Unanderra Wollongong, NSW, 2526
Tel: +61 2 4271 18 77
Fax: +61 2 4271 84 32

BRAZIL

STAUFF Brasil Ltda.
Avenida Gupê 10767
Galpão 2 - Bloco A
Barueri - São Paulo
CEP 06422-120
Tel: +55 11 47 72 72 00
Fax: +55 11 47 72 72 10

CHINA

STAUFF Intern.Trading Co., Ltd.
Shangdian Mansion, Pudong
331, Binzhou Road
200126 Shanghai
Tel: +86 21 58 45 65 60
Fax: +86 21 58 45 66 80

FRANCE

STAUFF S.A.
230, Avenue du Grain d'Or
Z.I. de Vineuil - Blois Sud
41354 Vineuil-cedex
Tel: +33 2 54 50 55 50
Fax: +33 2 54 42 29 19

GERMANY

Walter Stauffenberg GmbH & Co. KG
Postfach 1745
58777 Werdohl
Im Ehrenfeld 4
58791 Werdohl
Tel: +49 23 92 916-0
Fax: +49 23 92 2505

INDIA

STAUFF India Pvt. Ltd.
Gat. No. 2340
Pune Nagar Road, Wagholi
Pune, 412207
Tel: +91 202 705 19 90
Fax: +91 202 705 19 89

ITALY

STAUFF Italia S.r.l.
Via Pola 21/23
20034 Birone di Giussano
Tel: +39 0362 312113
Fax: +39 0362 335536

KOREA

STAUFF Korea Ltd.
1500-12, Dadae-Dong
Saha-Ku
Pusan, Korea 604-826
Tel: +82 51 266 6666
Fax: +82 51 266 8866

NEW ZEALAND

Stauff Corporation (NZ) Ltd.
P.O. Box 58517,
Greenmount, Auckland
Unit D, 103 Harris Road
East Tamaki, Auckland
Tel: +64 9 271 48 12
Fax: +64 9 271 48 32

POLAND

STAUFF Polska Sp. z o.o.
ul. Rdestowa 51
81-591 Gdynia
Tel: +48 58 660 11 60
Fax: +48 58 629 79 52

UNITED KINGDOM

STAUFF UK
332, Coleford Road
Darnall
Sheffield, S9 5PH
Tel: +44 114 251 85 18
Fax: +44 114 251 85 19

GLOBALLY AVAILABLE THROUGH DISTRIBUTORS IN ALL INDUSTRIAL COUNTRIES.

UNITED STATES OF AMERICA

STAUFF Corporation
7 Wm. Demarest Place
Waldwick, New Jersey 07463-1542
Tel: +1 201 444 7800
Fax: +1 201 444 7852
www.stauffusa.com
sales@stauffusa.com

CANADA

STAUFF Canada Ltd.
866 Milner Avenue
Scarborough
Ontario M1B 5N7
Tel: +1 416 282 4608
Fax: +1 416 282 3039
www.stauffcanada.com
sales@stauffcanada.com

YOUR LOCAL DISTRIBUTOR: