

Haldex

ROTARY GEAR FLOW DIVIDERS

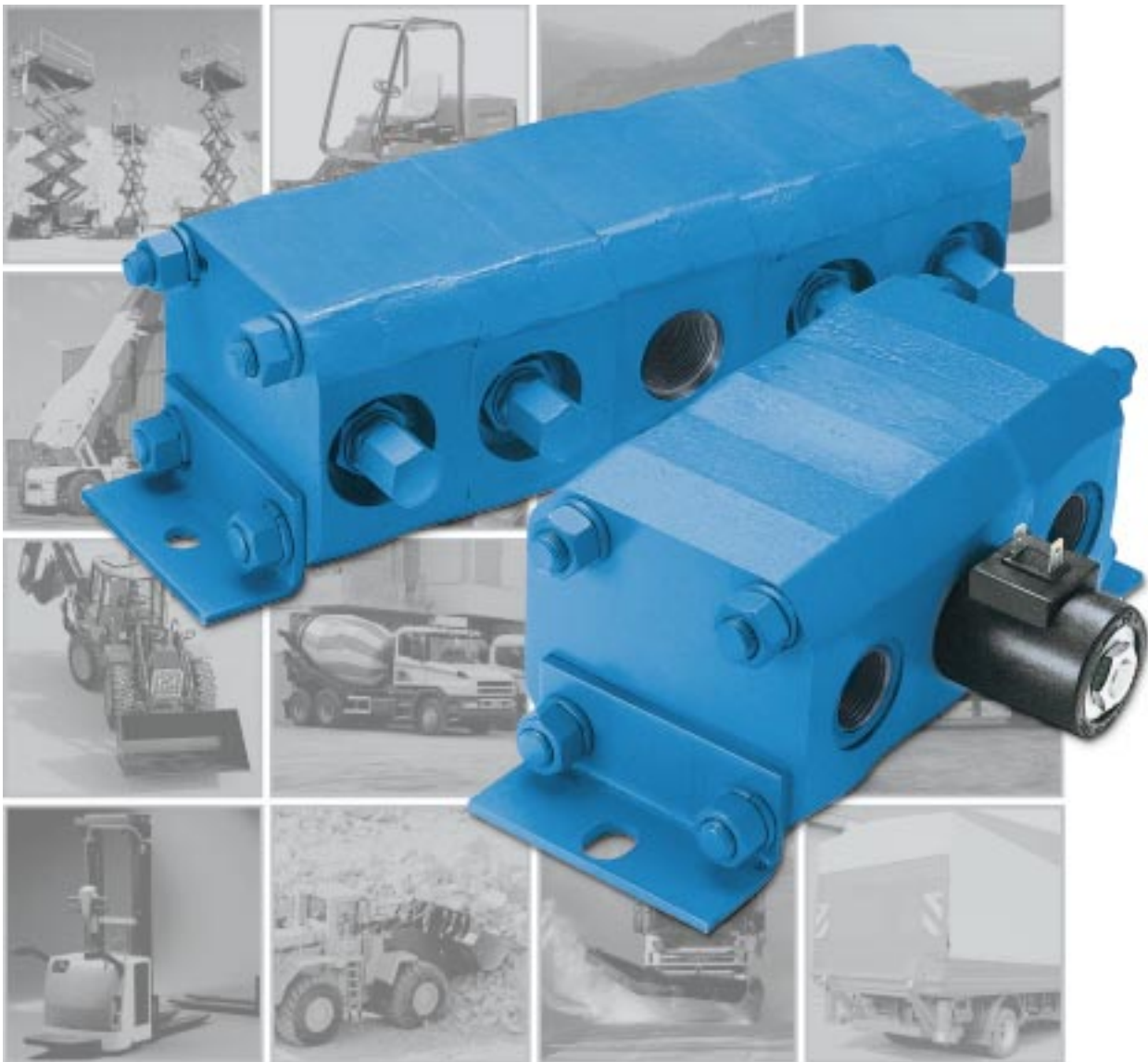

GC and D Series Rotary Gear Flow Dividers

Intensifier - Combiner (European and U.S. Versions)

Field-proven Haldex Hydraulic Systems' Rotary Gear Flow Dividers are providing efficient, reliable service for a wide variety of applications in agricultural, materials handling, and construction equipment. These hydraulic flow dividers provide many useful functions from a single pump source:

- Synchronized operation of multiple cylinders or fluid motors.
- Proportional division of pump output among several circuits.
- Intensified pressure when pressure higher than pump capacity is needed.

WHY ROTARY GEAR FLOW DIVIDERS INSTEAD OF SPOOL TYPE DIVIDERS?

Connected within the hydraulic circuit, rotary gear flow dividers operate automatically and only when needed. They require no maintenance.

In a rotary gear divider, horsepower-in is equal to horsepower-out with very small efficiency losses. Consequently, it does not generate heat. Since the efficiency of the unit is a function of the pressure drop across the section, **efficiencies approaching 98 percent are not uncommon.** This enhances the overall system effectiveness. Spool type dividers require a significant pressure drop just to operate. Heat is designed in when spool type dividers are incorporated in an application. Much care has to be taken to accommodate the inherent inefficiencies of spool type dividers when sizing them for an application.

Rotary gear flow dividers are also more tolerant of contamination and more rugged than spool type flow dividers. Spool type dividers can be accurate and exhibit little internal leakage but their cost is generally as much as 25% greater than comparable rotary gear dividers.

DIFFERENTIAL RELIEF VALVES

Our modular design allows us to add differential relief valves in each section of our flow dividers. These valves are not system relief valves. They are commonly used in applications where cylinders must be synchronized. They also serve to protect the flow divider against excessive differential pressure in the divider which could be caused by actuators becoming stalled or restricted.

APPLICATION OF A ROTARY GEAR FLOW DIVIDER IN A CYLINDER CIRCUIT

Rotary Gear Flow Dividers are designed to synchronize hydraulic cylinders (bring them to equal stroke length) in one direction only. This needs to be in a direction where the cylinders bottom out (go to the end of their stroke). The synchronizing is accomplished because excess fluid is bled off over the flow divider's internal relief valves to feed the cylinder that is late getting to the end of its stroke. Reversing the direction of the cylinders, the Rotary Gear Flow Divider will act as a combiner with the same efficiency as a divider. Please note that a combiner doesn't regulate cylinder speed, so a flow control is required to limit maximum flow.

ROTARY GEAR FLOW DIVIDER USED AS AN INTENSIFIER

Press and clamping circuits that require high flow at low pressure and low flow at high pressure are good applications for Rotary Gear Flow Dividers to intensify pressure. High flow from the outputs of the divider are combined until high pressure is required, then one or more of the divider outputs are dumped to tank giving high pressure in the intensified circuit. Caution is required so that the pressure does not exceed the rating of the flow divider.

WHAT'S NEW AND INNOVATIVE ABOUT HALDEX ROTARY GEAR FLOW DIVIDERS?

We have earned a reputation over the last 70 years as innovators and systems specialists. We go beyond the basic requirements for hydraulic components to analyze the total system goals. In doing this, many times we find that we can help solve a customer's system problem by doing something different to our product. The following are examples of how we have done this with flow dividers:

SOLENOID ACTUATED 2-WAY VALVES FOR FLUID MOTOR DRIVE APPLICATIONS

This feature provides operator selection between a positive traction drive or differential drive on turf care vehicles, small utility vehicles and various mobile lift devices. This feature is available in 2, 3 or 4 section dividers.

ADJUSTABLE NEEDLE VALVE BETWEEN SECTIONS

to allow only the set amount of flow providing the desired differential effect for drive motors. It can also be adjusted for varying tire ratios.

WHY HALDEX VS. OTHER ROTARY GEAR FLOW DIVIDERS?

Haldex GC series flow dividers are of cast iron construction with 1/2" diameter shaft and needle bearings for high pressure operation. The gear bores are held to extremely close tolerances to provide maximum efficiency. They are lighter weight than many competitors because no interface plates are required between sections. This feature also insures better shaft alignment and fewer leakage paths. Seal plates between each section provide additional insurance against leakage. The modular design easily accommodates multiple gear width combinations and multiple porting options. Haldex D series flow dividers incorporate the above features but substitute a 5/8" diameter shaft and needle bearings. The D series also substitutes o-ring seals between each section for enhanced sealing.

INSIDE THIS CATALOG ...

This catalog combines both GC and D series flow divider information, including European versions. We have included performance and dimensional information as well.

Please review the information provided to get a general understanding of what Haldex Hydraulic Systems can offer your company. To answer your specific needs, please contact us. We have an excellent track record for meeting unique hydraulic system challenges.

Pictures on front cover are used with the kind permission of eg: Atlet, BT, Huddig, Scania, Toro and Volvo Construction Equipment.

GC Series Rotary Gear Flow Dividers

Order Code	Gear Face Width	Displacement		SAE Ports		Minimum Flow/Sec		Maximum Flow/Sec		Cont. Diff. Pressure Between Inlet/Outlet		Maxium Outlet Pressure Any Section	
		In. ³	Cm. ³	Inlet	Outlet	GPM	L/M	GPM	L/M	PSI	BAR	PSI	BAR
06	3/16	.097	1.59	9/16-18	9/16-18	0.8	3.0	1.7	6.4	1800	124	3500	241
* 08	1/4	.129	2.12	3/4-16	3/4-16	1.2	4.5	2.5	9.5				
12	3/8	.194	3.18	3/4-16	9/16-18	1.7	6.4	4.5	13.2				
* 16	1/2	.258	4.24	7/8-14	7/8-14	2.5	9.5	5.0	18.9				
20	5/8	.323	5.30	7/8-14	7/8-14	3.0	11.4	6.0	22.7				
* 24	3/4	.388	6.36	7/8-14	7/8-14	3.5	13.2	7.0	26.5	1600	110		
28	7/8	.453	7.42	7/8-14	7/8-14	4.0	15.1	8.0	30.3	1300	90		
* 32	1	.517	8.48	7/8-14	7/8-14	4.5	17.0	9.0	34.1	1200	83		

NOTE: Flows listed above are per section.

For **European Style GC Flow Dividers**, all inlet and outlet ports are 1/2-14 BSPP.

* Stock units available in two and four section versions, see page 9.

MAXIMUM inlet pressure 3000 psi (207 bar) • **MAXIMUM** outlet pressure 3500 psi (241 bar). For 3 section flow dividers or flow dividers with unequal sections, contact the factory. Recommended operating range 2000 rpm to 3500 rpm.

Performance

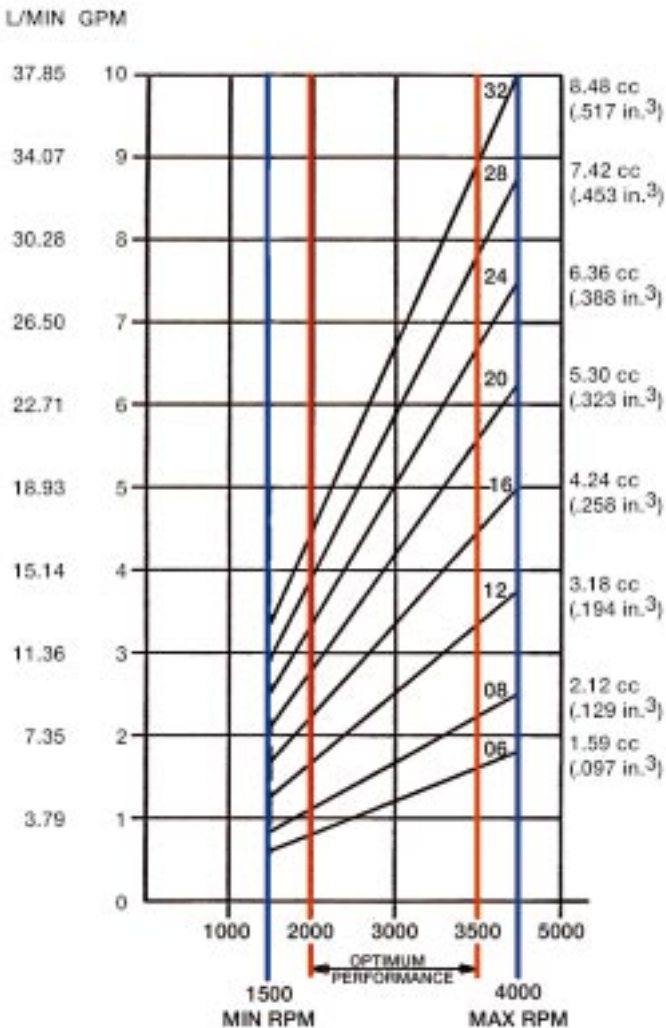

The curve on the left and the chart above can be useful in selecting the proper size flow divider sections. The curve shows speed vs. flow per section.

For equal sized sections:

Assume four section dividers with a total flow of 12 GPM (45.4 L/M) in and 3 GPM (11.4 L/M) per section out. From the chart, an order code 12 or 20 would be suitable for this flow. However, the nearer the mid-range, the better the efficiency. From the curve, order code 16 crosses the 3 GPM (11.4 L/M) line at 2750 RPM. The best selection is the order code 16 gear section.

For proportional flow, the curve is used as follows:

Assume a four section divider with an input flow of 19 GPM (71.9 L/M) and an outlet flow of 7 GPM (26.5 L/M), 5 GPM (18.9 L/M), 4 GPM (15.1 L/M), and 3 GPM (11.4 L/M). With a straight edge on the 3000 RPM line, proper flow for 7 GPM (26.5 L/M) is given with an order code 32 gear section, 5 GPM (18.9 L/M) with an order code 24 gear section, 4 GPM (15.1 L/M) with an order code 20 gear section and 3 GPM (11.4 L/M) with an order code 16 gear section.

The chart above also shows the allowable differential pressures. The differential relief valve setting is determined by the maximum pressure needed by the circuit minus the inlet pressure without exceeding the allowable differential pressure. Either the continuous or intermittent differential pressures are used, depending on the circuit requirement. The differential relief valve is adjustable through a range of 500 - 1000 PSI (34.5 - 69 BAR). Our standard setting for the differential relief valves is 750 PSI (51.7 BAR).

D Series Rotary Gear Flow Dividers

Order Code	Gear Face Width	Displacement		SAE Ports		Minimum Flow/Sec		Maximum Flow/Sec		Continuous Differential Between Sections		Intermittent Differential Between Sections	
		In. ³	Cm. ³	Inlet	Outlet	GPM	L/M	GPM	L/M	PSI	BAR	PSI	BAR
08	1/4	.232	3.81	7/8-14	9/16-18	2	7.6	4	15.2	3000	207	3000	207
* 12	3/8	.349	5.71	1 5/16-12	3/4-16	3	11.4	6	22.9	2750	190	3000	207
16	1/2	.465	7.62	1 5/16-12	3/4-16	4	15.2	8	30.5	2500	172	3000	207
* 20	5/8	.581	9.52	1 5/16-12	7/8-14	5	19.0	10	38.1	2000	138	2750	190
24	3/4	.697	11.43	1 5/16-12	7/8-14	6	22.9	12	45.7	1500	103	2250	155
* 28	7/8	.813	13.33	1 5/16-12	1 1/16-12	7	26.7	14	53.3	1200	83	1750	121

NOTE: Flows listed above are per section.

* Stock units available in two and four section versions, see page 9.

MAXIMUM inlet pressure 3000 psi (207 bar) • MAXIMUM outlet pressure 4500 psi (310.3 bar). For 3 section flow dividers or flow dividers with unequal sections, contact the factory. Recommended operating range 2000 rpm to 4000 rpm. NOTE: Do not exceed 4500 rpm.

Performance

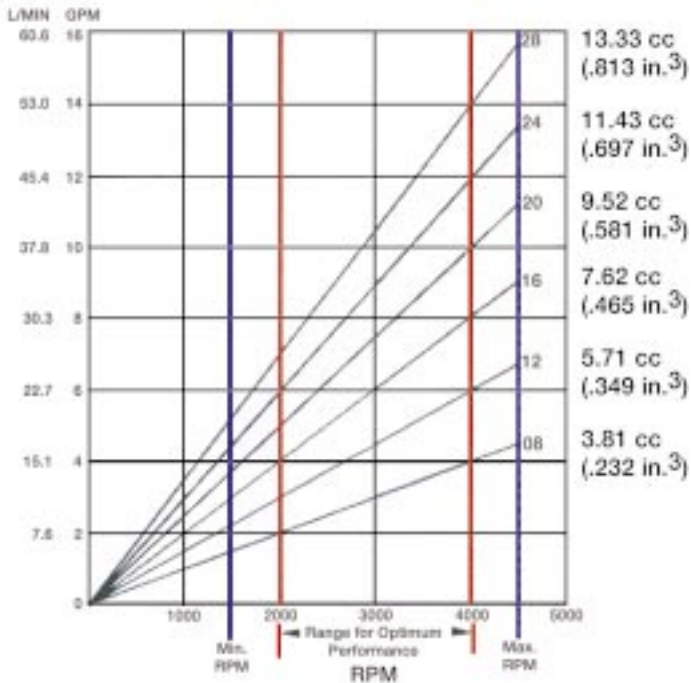

The curve on the left and the chart above can be useful in selecting the proper size flow divider sections. The curve shows speed vs. flow per section.

For equal sized sections:

Assume two section dividers with a total flow of 16 GPM (60.6 L/M) in and 8 GPM (30.3 L/M) per section out. From the chart, an order code 16, 20, 24 or 28 would be suitable for this flow. However, the nearer the mid-range, the better the efficiency. From the curve, order code 20 crosses the 8 GPM (30.3 L/M) line at 3200 RPM. The best selection is the order code 20 gear section.

For proportional flow, the curve is used as follows:

Assume a three section divider with an input flow of 20 GPM (75.7 L/M) and an outlet flow of 10 GPM (37.9 L/M), 7 GPM (26.5 L/M), and 3 GPM (11.4 L/M). With a straight edge on the RPM line, note the 10 GPM (37.9 L/M) line at 2800 RPM gives the proper flow with an order code 28 gear section, an order code 20 gear section and an order code 08 gear section.

The chart above also shows the allowable differential pressures. The differential relief valve setting is determined by the maximum pressure needed by the circuit minus the inlet pressure without exceeding the allowable differential pressure. Either the continuous or intermittent differential pressures are used, depending on the circuit requirement. The differential relief valve is adjustable through a range of 500 - 1000 PSI (34.5 - 69 BAR). Our standard setting for the differential relief valves is 750 PSI (51.7 BAR).

2 Section GC Series Flow Divider U.S. & European Style

NOTE: The only difference between the U.S. version and European version is the porting configuration. The U.S. version has SAE standard ports (refer to page 3) and the European version has 1/2-14 BSPP ports.

(inches are in brackets)

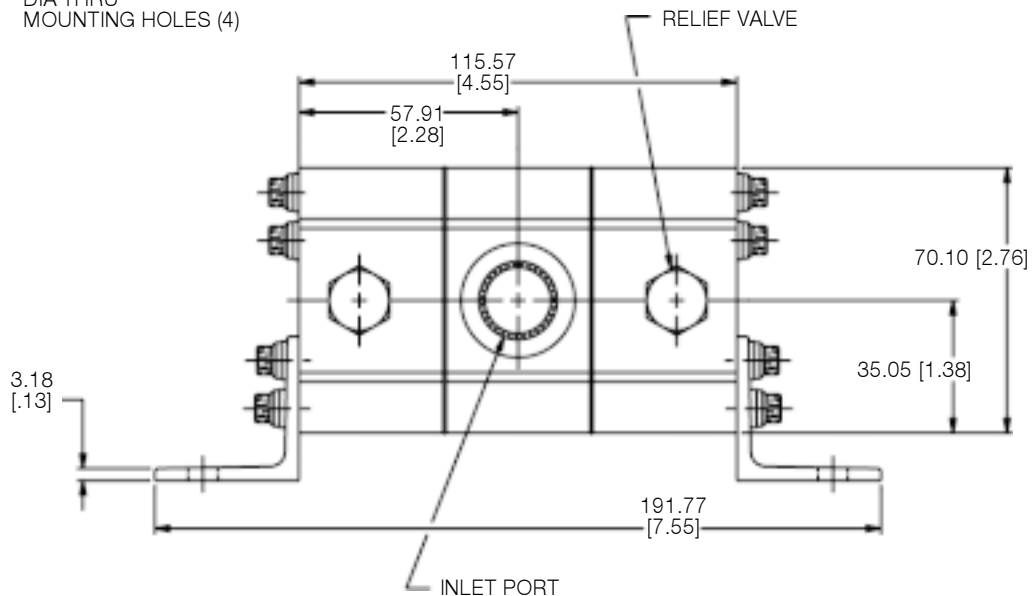
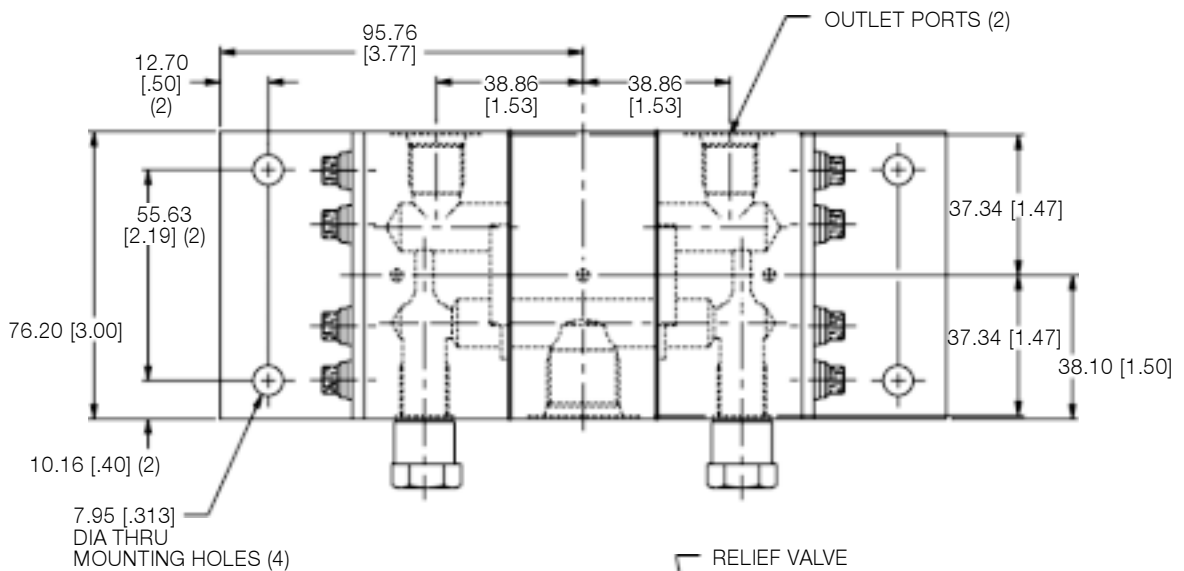
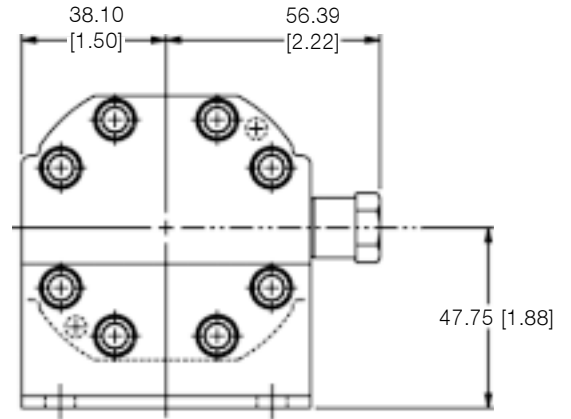
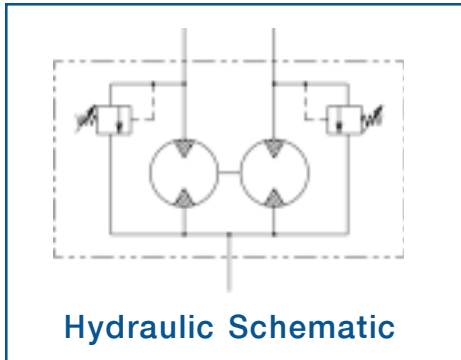

4 Section GC Series Flow Divider U.S. & European Style

NOTE: The only difference between the U.S. version and European version is the porting configuration. The U.S. version has SAE standard ports (refer to page 3) and the European version has 1/2-14 BSPP ports.

(inches are in brackets)

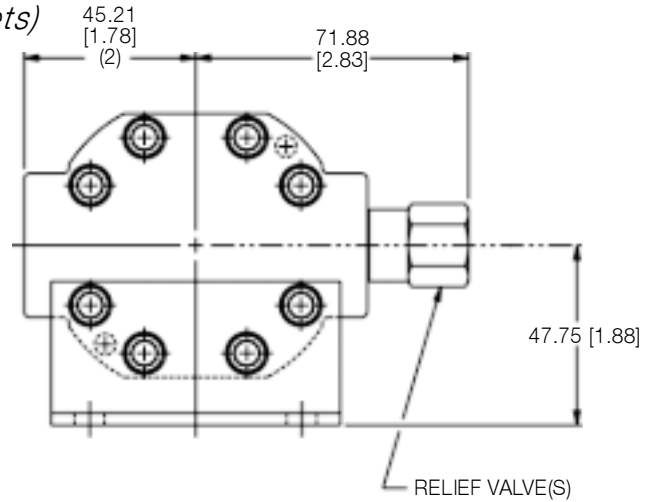
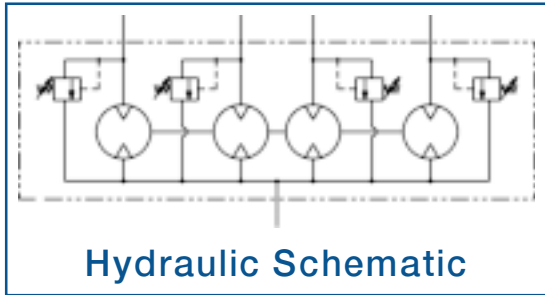

2 Section D Series Flow Divider

(inches in brackets)

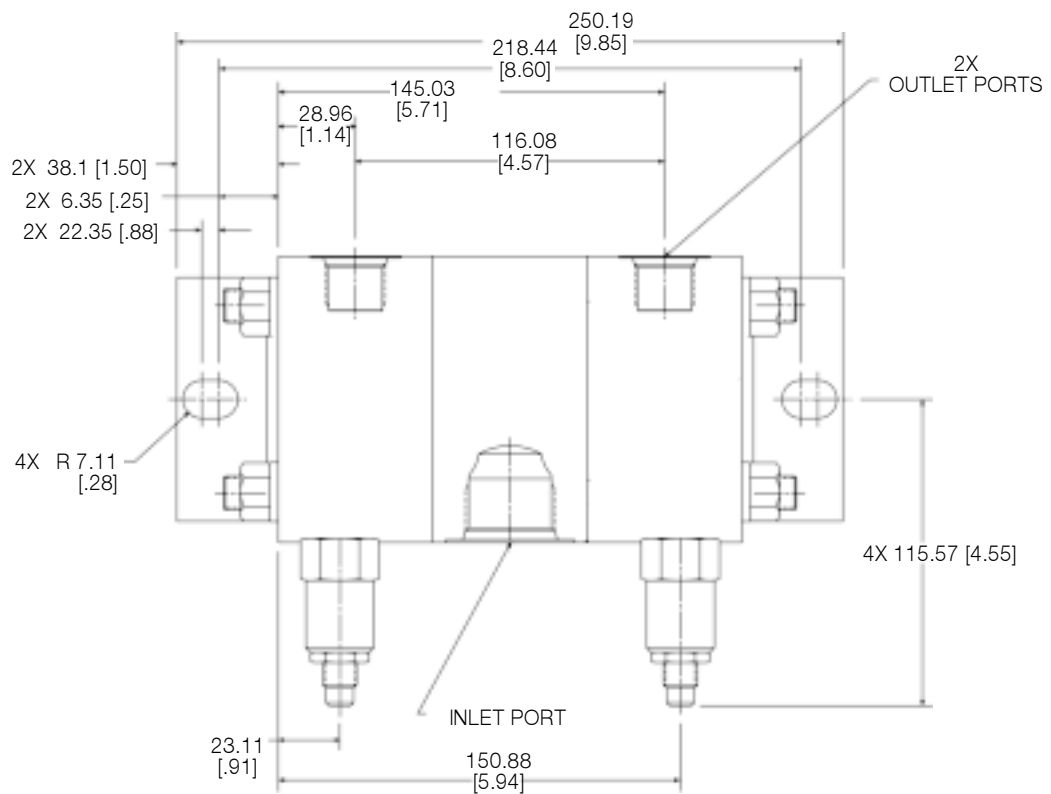
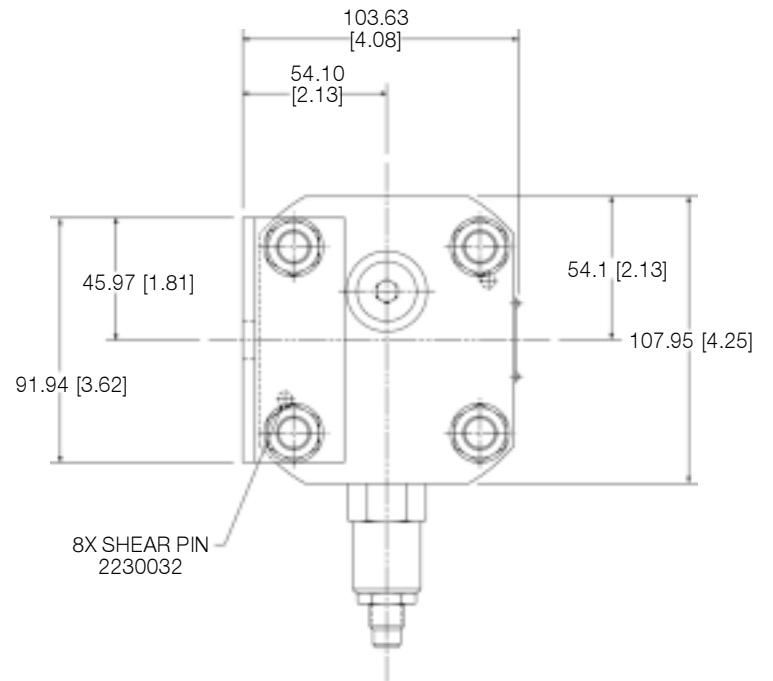
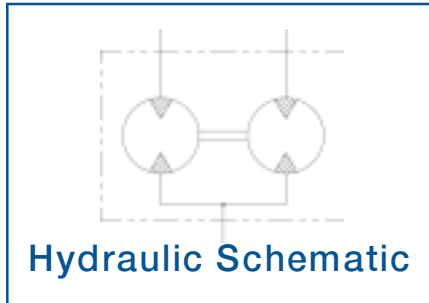

4 Section D Series Flow Divider

(inches in brackets)

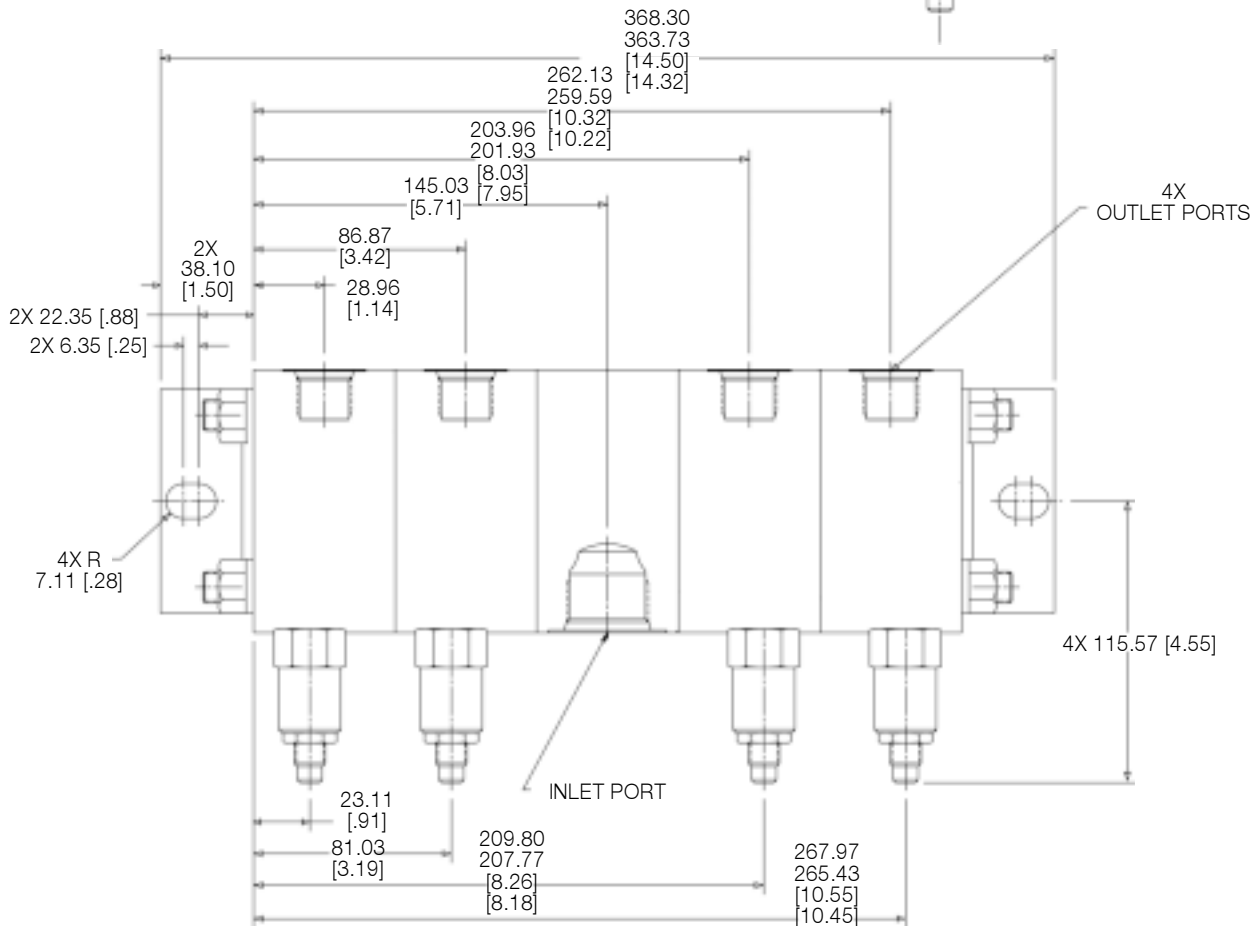
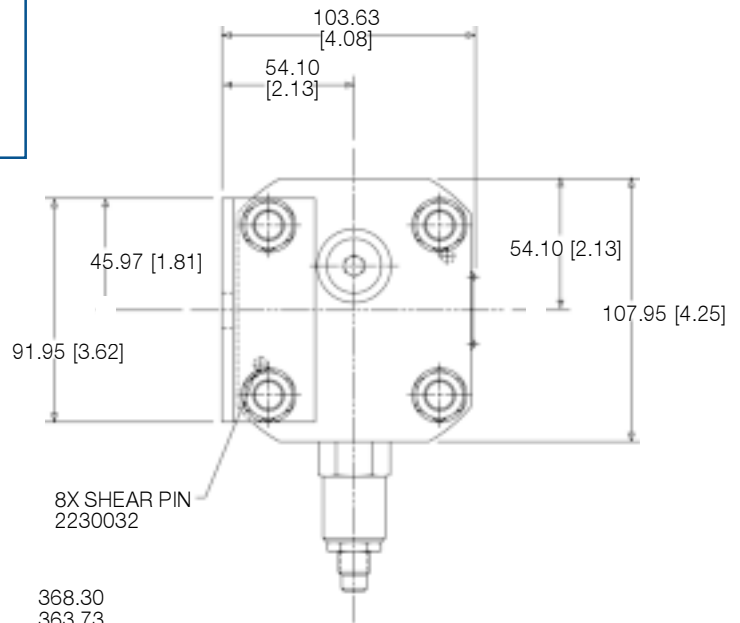
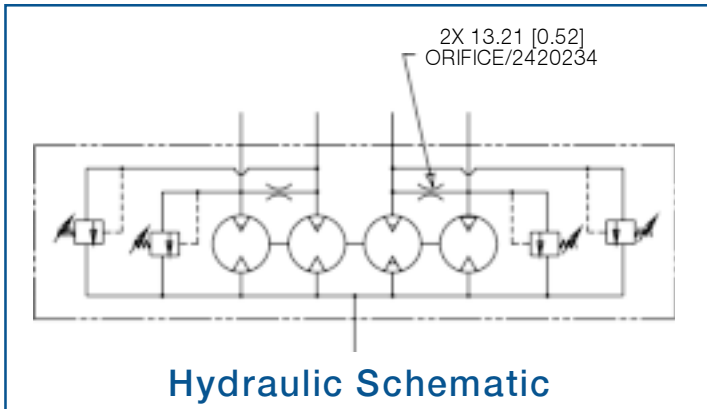

Stock Haldex Hydraulic Systems Flow Dividers

GC Series (U.S. Version) Flow Dividers

Sections	Ports (SAE)		Relief Valve	Displacement in. ³ Per Section	Model Code X-Ref	Stock P/N
	Inlet	Outlet				
2	3/4-16	3/4-16	Included	.129	FG1220021	1300634
2	7/8-14	7/8-14	Included	.258	FG1440021	1300635
2	7/8-14	7/8-14	Included	.388	FG1770021	1300636
2	7/8-14	7/8-14	Included	.517	FG1990021	1300637
4	3/4-16	3/4-16	Included	.129	FG3222221	1303139
4	7/8-14	9/16-18	Included	.258	FG3444421	1303140
4	7/8-14	3/4-16	Included	.388	FG3777721	1303142
4	7/8-14	7/8-14	Included	.517	FG3999921	1303143

GC Series (European Version) Flow Dividers

Sections	Ports (BSPP)		Relief Valve	Displacement cc Per Section	Model Code X-Ref	Stock P/N
	Inlet	Outlet				
2	1/2-14	1/2-14	Included	2.11	FG1220023	1303144
2	1/2-14	1/2-14	Included	3.18	FG1330023	1303165
2	1/2-14	1/2-14	Included	4.24	FG1440023	1303149
4	1/2-14	1/2-14	Included	2.11	FG3222223	1303157
4	1/2-14	1/2-14	Included	4.24	FG3444423	1303147

D Series Flow Dividers

Sections	Ports (SAE)		Relief Valve	Displacement in. ³ Per Section	Model Code X-Ref	Stock P/N
	Inlet	Outlet				
2	1 5/16-12	7/8-14	Included	.581 (9.5 cc)	FD2-0-V20S7.5-20S7.5-0-B10	1300315
2	1 5/16-12	3/4-16	Included	.348 (5.7 cc)	FD2-0-V12Q7.5-12Q7.5-0-B10	1300322
4	1 5/16-12	7/8-14	Included	.581 (9.5 cc)	FD2-V20S7.5-20S7.5-20S7.5-20S7.5-B10	1300323
4	1 5/16-12	3/4-16	Included	.348 (5.7 cc)	FD2-V12Q7.5-12Q7.5-12Q7.5-B10	1300324
2	1 5/16-12	1 1/16-12	Included	.813 (13.3 cc)	FD2-0-V28T7.5-28T7.5-0-B10	1300352
4	1 5/16-12	1 1/16-12	Included	.813 (13.3 cc)	FD2-V28T7.5-28T7.5-28T7.5-28T7.5-B10	1300353

How To Order Haldex GC Series Flow Dividers

Haldex Hydraulic Systems stocks a selection of GC Series two section and four section flow dividers, which include a built-in adjustable differential relief valve in each section. See page 9 for a list of stock available. If the GC Series flow divider required is not a stock item at Haldex, it may be ordered by following the ordering code show below. Non-stock options require a 100-piece minimum.

Determine the number of sections needed.
Determine gear size of sections required:
Fill in all blanks in model code below:

1 2 3 4 5 6 7 8 9
F G _ _ _ _ _ _ _ _

1.	Type	F	Flow Divider
2.	Series	G	GC Series Flow Divider
3.	Number of Sections	1	Two Sections
		2	Three Sections
		3	Four Sections

EXAMPLE: FG1440021

Two section flow divider, .258 in.³/rev. gear first section, .258 in.³/rev. gear second section, no 3rd or 4th section, relief valve in each section, SAE ports.

4.	Gear Size(s) (each section)	
5,	0	None
6,	1	.097 in. ³ /rev.
7.	2	.129 in. ³ /rev.
	3	.194 in. ³ /rev.
	4	.258 in. ³ /rev.
	5	.291 in. ³ /rev.
	6	.323 in. ³ /rev.
	7	.388 in. ³ /rev.
	8	.453 in. ³ /rev.
	9	.517 in. ³ /rev.
8.	Relief Valve	
	1	None
	2	One Each Section
9.	Porting	
	1	SAE (Standard)
	2	NPTF

How To Order Haldex GC Series Flow Dividers (European Version)

Haldex Hydraulic Systems stocks a selection of GC Series two section and four section flow dividers (European Version), which include a built-in adjustable differential relief valve in each section. See page 9 for a list of stock available. If the GC Series flow divider required is not a stock item at Haldex, it may be ordered by following the ordering code show below. Non-stock options require a 100-piece minimum.

Determine the number of sections needed.
Determine gear size of sections required:
Fill in all blanks in model code below:

1 2 3 4 5 6 7 8 9
F G _ _ _ _ _ _ _ _

1.	Type	F	Flow Divider
2.	Series	G	GC Series Flow Divider
3.	Number of Sections	1	Two Sections
		2	Three Sections
		3	Four Sections

EXAMPLE: FG1220023

Two section flow divider, 2.11 cc/rev. gear first section, 2.11 cc/rev. gear second section, no 3rd or 4th section, relief valve in each section, BSPP ports.

4.	Gear Size(s) (each section)	
5,	0	None
6,	1	1.58 cc/rev.
7.	2	2.11 cc/rev.
	3	3.18 cc/rev.
	4	4.24 cc/rev.
	5	4.76 cc/rev.
	6	5.29 cc/rev.
	7	6.36 cc/rev.
	8	7.42 cc/rev.
	9	8.47 cc/rev.
8.	Relief Valve	
	1	None
	2	One Each Section
9.	Porting	
	3	BSPP

How To Order Haldex D Series Flow Dividers

Haldex Hydraulic Systems stocks a selection of D Series two section and four section flow dividers, which include a built-in adjustable differential relief valve in each section. See page 9 for a list of stock available. If the D Series flow divider required is not a stock item at Haldex, it may be ordered by following the ordering code show below. Non-stock options require a 100-piece minimum.

EXAMPLE: FD2-V28T7.5-28T7.528T7.5-28T7.5-B10

D Series Flow Divider, two section flow divider, #16 SAE 1-5/16" - 12 inlet port, .813 in.³/rev. (13.3 cc/rev.) Position A Section Displacement, #12 SAE 1-1/16" - 12 Position A Section Outlet Port, 750 PSI (51.7 BAR) Position A Section Relief Valve, .813 in.³/rev. (13.3 cc/rev.) Position B Section Displacement, #12 SAE 1-1/16" - 12 Position B Section Outlet Port, 750 PSI (51.7 BAR) Position B Section Relief Valve, .813 in.³/rev. (13.3 cc/rev.) Position C Section Displacement, #12 SAE 1-1/16" - 12 Position C Section Outlet Port, 750 PSI (51.7 BAR) Position C Section Relief Valve, .813 in.³/rev. (13.3 cc/rev.) Position D Section Displacement, #12 SAE 1-1/16" - 12 Position D Section Outlet Port, 750 PSI (51.7 BAR) Position D Section Relief Valve, Standard Bracket, Design Series 10 (standard).

1. Paint Option	
P1	Standard Black
P2	Grey
2. Model Series	
FD	D Series Flow Divider
3. Number of Sections	
2	Two Sections
3	Three Sections
4	Four Sections
4. Inlet Port	
S	#10 SAE 7/8" - 14 (Displacement 08 only)
T	#12 SAE 1-1/16" - 12
V	#16 SAE 1-5/16" - 12 (Except Displacement 08)
5. Position A Section Displacement Code	
08	.232 in. ³ /rev. (3.8 cc/rev.)
12	.348 in. ³ /rev. (5.7 cc/rev.)
16	.465 in. ³ /rev. (7.6 cc/rev.)
20	.581 in. ³ /rev. (9.5 cc/rev.)
24	.697 in. ³ /rev. (11.4 cc/rev.)
28	.813 in. ³ /rev. (13.3 cc/rev.)
6. Position A Section Outlet Port	
H	9/16" - 18 SAE
Q	#8 SAE 3/4" - 16
S	#10 SAE 7/8" - 14 (Displacement 08 only)
T	#12 SAE 1-1/16" - 12
V	#16 SAE 1-5/16" - 12 (Except Displacement 08)
7. Position A Section Relief Valve	
Omit	No Valve
15	1500 PSI (103.5 BAR)
7.5	750 PSI (51.7 BAR)
8. Position B Section Displacement Code	
08	.232 in. ³ /rev. (3.8 cc/rev.)
12	.348 in. ³ /rev. (5.7 cc/rev.)
16	.465 in. ³ /rev. (7.6 cc/rev.)
20	.581 in. ³ /rev. (9.5 cc/rev.)
24	.697 in. ³ /rev. (11.4 cc/rev.)
28	.813 in. ³ /rev. (13.3 cc/rev.)
9. Position B Section Outlet Port	
H	9/16" - 18 SAE
Q	#8 SAE 3/4" - 16
S	#10 SAE 7/8" - 14 (Displacement 08 only)
T	#12 SAE 1-1/16" - 12
V	#16 SAE 1-5/16" - 12 (Except Displacement 08)

10. Position B Section Relief Valve	
Omit	No Valve
15	1500 PSI (103.5 BAR)
7.5	750 PSI (51.7 BAR)
11. Position C Section Displacement Code	
08	.232 in. ³ /rev. (3.8 cc/rev.)
12	.348 in. ³ /rev. (5.7 cc/rev.)
16	.465 in. ³ /rev. (7.6 cc/rev.)
20	.581 in. ³ /rev. (9.5 cc/rev.)
24	.697 in. ³ /rev. (11.4 cc/rev.)
28	.813 in. ³ /rev. (13.3 cc/rev.)
12. Position C Section Outlet Port	
H	9/16" - 18 SAE
Q	#8 SAE 3/4" - 16
S	#10 SAE 7/8" - 14 (Displacement 08 only)
T	#12 SAE 1-1/16" - 12
V	#16 SAE 1-5/16" - 12 (Except Displacement 08)
13. Position C Section Relief Valve	
Omit	No Valve
15	1500 PSI (103.5 BAR)
7.5	750 PSI (51.7 BAR)
14. Position D Section Displacement Code	
08	.232 in. ³ /rev. (3.8 cc/rev.)
12	.348 in. ³ /rev. (5.7 cc/rev.)
16	.465 in. ³ /rev. (7.6 cc/rev.)
20	.581 in. ³ /rev. (9.5 cc/rev.)
24	.697 in. ³ /rev. (11.4 cc/rev.)
28	.813 in. ³ /rev. (13.3 cc/rev.)
15. Position D Section Outlet Port	
H	9/16" - 18 SAE
Q	#8 SAE 3/4" - 16
S	#10 SAE 7/8" - 14 (Displacement 08 only)
T	#12 SAE 1-1/16" - 12
V	#16 SAE 1-5/16" - 12 (Except Displacement 08)
16. Position D Section Relief Valve	
Omit	No Valve
15	1500 PSI (103.5 BAR)
7.5	750 PSI (51.7 BAR)
17. Bracket	
B	Standard Bracket
Omit	No Bracket
18. Design Series	
10	Standard



PRODUCT RANGE

He Power Packs
12/24/48 VDC 0.8 – 3.5 kW and
0.75 – 3 kW AC modular power
packs

Pressure Switches
5 - 350 bar, connecting/
disconnecting

He Classic Power Packs
12/24/48 VDC modular
powerpacks in weatherproof
boxes

W100 Hydraulic pumps
0.5 – 2.0 cc/section, 227 bar

W300 Hydraulic pumps
0.8 – 5.7 cc/section, 230 bar

W600 Hydraulic pumps
4 – 12 cc/section, 276 bar

WM600 Hydraulic motors
4 – 12 cc/section, 276 bar

W900 Hydraulic pumps
5 – 31 cc/section, 276 bar

WM900 Hydraulic motors
5 - 31 cc/section, 276 bar

WQ900 The quiet pump
5 - 23 cc/section, 230 bar

W1500 Hydraulic pumps
19 - 50 cc/section, 276 bar

WM1500 Hydraulic motors
19 - 50 cc/section, 276 bar

G25 Hydraulic pumps
23 – 87 cc/section, 250 bar

GM25 Hydraulic motors
23 – 87 cc/section, 250 bar

GPA Internal Gear pumps
1.7 – 63 cc/section, 100 bar

GC Hydraulic pumps / fluid motors
1.06 – 11.65 cc/section, 276 bar

II-Stage Hydraulic pumps
4.2 – 22.8 cc/section, 276 bar

Rotary Flow Dividers
3.8 – 13.3 cc/section, 300 bar

D Hydraulic pumps
3.8 - 22.9 cc/section, 207 bar

H Hydraulic pumps
9.8 - 39.4 cc/section, 207 bar

G20/G30 Hydraulic pumps
23 – 161 cc/section, 276 bar

GM20/GM30 Hydraulic motors
23 – 161 cc/section, 276 bar

G20/G30 (LS) Hydraulic pumps
23 – 161 cc/section 276 bar

Transmission pumps

Fuel pumps

www.hbus.haldex.com



Haldex Hydraulics Corp.
2222 15th Street
ROCKFORD, IL 61104
USA
Tel: +1-815 398 4400
Fax: +1-815 398 5977
E-mail: info.hydraulics.us@haldex.com

Haldex Hydraulics Corp.
214 James Farm Road
STATESVILLE, NC 28625
USA
Tel: +1-704 873 2587
Fax: +1-704 878 0530
E-mail: info.hydraulics.us@haldex.com

Haldex Hydraulics AB
Box 95
SE-280 40 SK. FAGERHULT
Sweden
Tel: +46-433 32400
Fax: +46-433 30546
E-mail: info.hydraulics.eu@haldex.com

Haldex Hydraulics AB
Box 511
SE-195 25 ARLANDASTAD
Sweden
Tel: +46-8 591 288 50
Fax: +46-8 591 288 60
E-mail: info.hydraulics.eu@haldex.com

Haldex Hydraulics GmbH
Postfach 1507
D-95014 HOF
Germany
Tel: +49-9281 895-0
Fax: +49-9281 87133
E-mail: info.hydraulics.eu@haldex.com



Haldex is an innovator in vehicle technology supplying proprietary systems and components for trucks, cars and industrial vehicles, worldwide. With 4,100 employees and yearly sales exceeding 7 billion Swedish Kronor, Haldex is listed on the Stockholm Stock Exchange (www.haldex.com).