



W1500 SERIES HYDRAULIC PUMP



W1500

Hydraulic Gear Pump

PRESSURE

(P1) 276 BAR (4000 PSI)
(P2) 300 BAR (4400 PSI)

SPEED

3300 RPM
Min. 500 RPM at
4000 PSI (276 BAR)
Continuous

EFFICIENCY

Overall > 90%
Volumetric 98%
Mechanical 92%

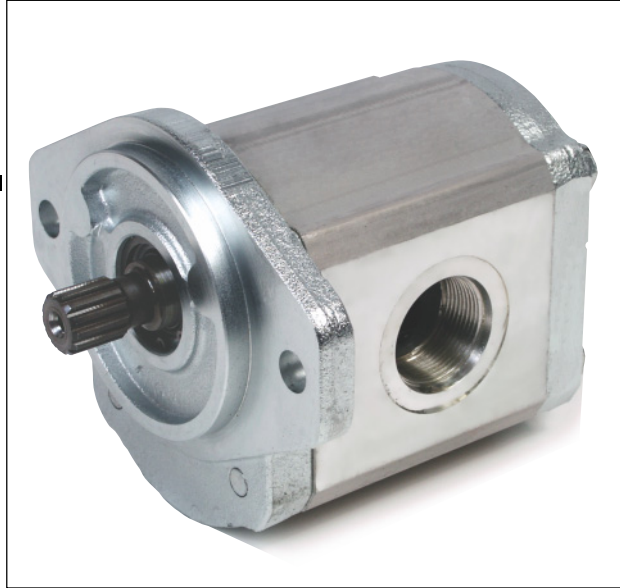

NOISE

14 Tooth Design
Superior trapping configuration
Optimum gear profile

FLEXIBILITY

SAE, ISO & DIN shafts
Mounting flanges, Port
styles, Integrated valves,
Multiple pumps

QUALITY

ISO 9001 Registered

The W1500 is one family in the W Series of high performance gear pumps and fluid motors. It is a through bore bushing type design constructed of high strength aluminum housings and cast iron end covers. The W Series is suitable for a wide range of equipment applications from material handling, agricultural, construction and paving to aerial lifts, winch and turf care.

The hydraulic performance, flexibility, high efficiency, low and high speed operation, low noise performance and the variety of options have established the W Series as the standard by which other pump performance is measured.

This catalog illustrates the options available for the W1500 family as well as performance and dimensional information. An easy to follow ordering guide is also included.

Performance Information

Model Code		190	230	250	280	330	380	440	500
Displacement	cm ³ /rev	19	23	25	28	33	38	44	50
	in ³ /rev	1.159	1.403	1.525	1.708	2.013	2.318	2.684	3.050
Inlet Pressure	BAR (PSI)	min. 0.2 BAR below atmospheric (6 IN.HG) max. 2.0 BAR (29 PSI)							
Max. Continuous Pressure (P1)	BAR	276 BAR						221	200
	PSI	4000 PSI						3200	2900
Max. Intermittent Pressure (P2)	BAR	300 BAR						243	220
	PSI	4400 PSI						3520	3190
Min. Rotational Speed At (P1)		500							
Max. Rotational Speed At (P1)		3300		3100		3000		2800	2700
Input Power @ P1 @ 1000 RPM	KW	9.54	11.55	12.55	14.06	16.57	19.08	17.67	18.20
	HP	12.8	15.5	16.8	18.9	22.2	25.6	23.7	24.4

DIMENSIONS & MOUNTING FLANGE OPTIONS 3

For its displacement and pressure range, the W1500 family features one of the most compact envelopes available from any manufacturer. Standard international mounting flange options are outlined below. Dimensions shown outside of brackets are metric units. See bottom of page 4 for dimensional chart showing "A", "B", "X", and "Y" dimensions.

SAE "A" 2-BOLT ORDER CODE 04

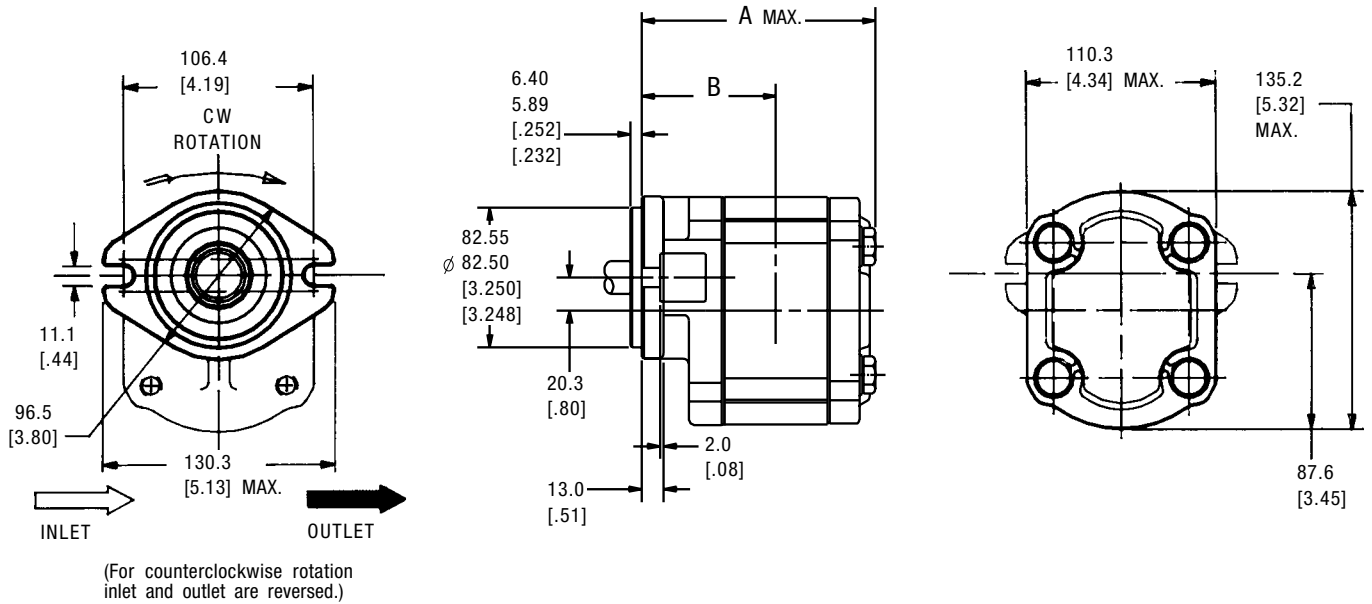

SAE "B" 2-BOLT ORDER CODE 05

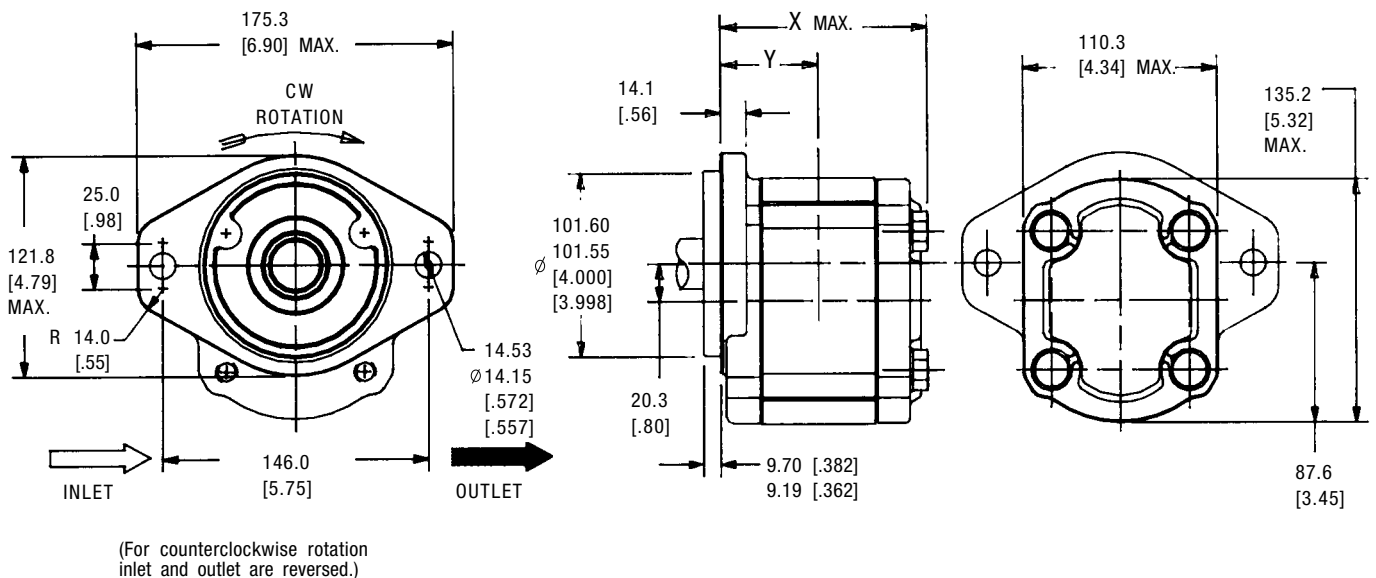

4 DIMENSIONS & MOUNTING FLANGE OPTIONS

RECTANGULAR (100.0 mm Pilot) ORDER CODE 08

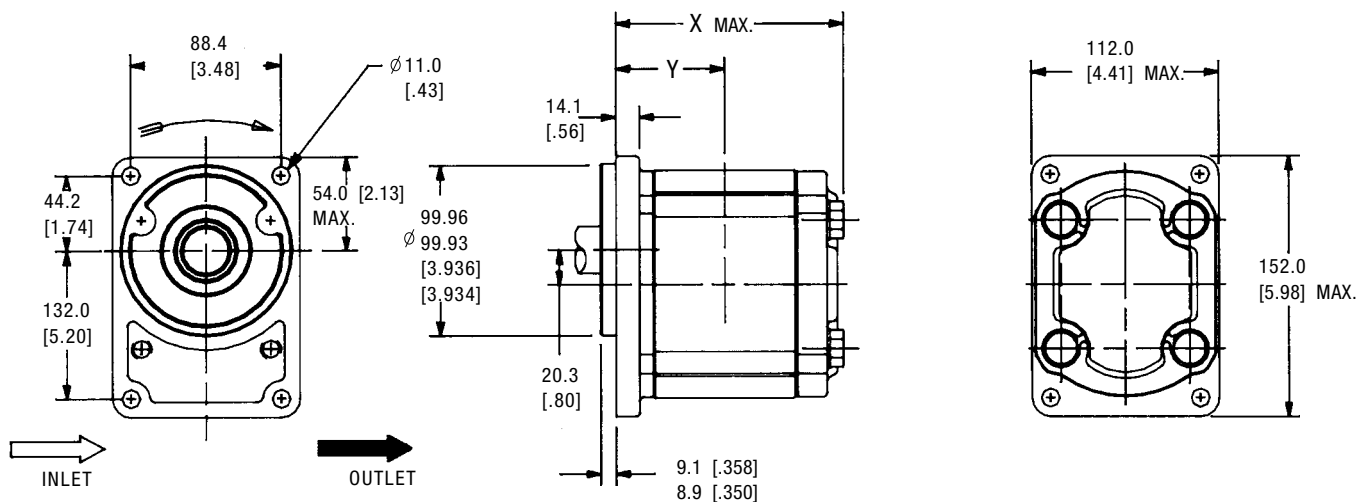

* NOTE: For port code options 05 & 06, subtract 2 mm from the port centerline dimension on the 19 cc displacement only.

** NOTE: For port code options 05 & 06, subtract 2 mm from the port centerline dimension on the 28 cc displacement only.

(See dimensional drawings on page 3 and above.)

Order Code	Displacement		Dims. & Weights with Flange Option 4			Dims. & Weights with Flange Options 5 & 8		
	CM ³	IN ³	A Max.	B (To Port Centerline)	Approx. Wt. kg. [lbs.]	X Max.	Y (To Port Centerline)	APPROX. Wt. kg. [lbs.]
190	19.0	1.159	152.0 [5.98]	* 89.3 [3.52]	8.44 [18.62]	124.5 [4.90]	* 63.3 [2.49]	8.04 [17.73]
230	23.0	1.403	156.2 [6.15]	91.4 [3.60]	8.64 [19.05]	128.7 [5.07]	65.4 [2.57]	8.23 [18.14]
250	25.0	1.525	158.4 [6.24]	92.5 [3.64]	8.74 [19.27]	130.9 [5.15]	66.6 [2.62]	8.32 [18.35]
280	28.0	1.708	161.4 [6.35]	** 94.0 [3.70]	8.88 [19.59]	133.9 [5.27]	** 68.0 [2.68]	8.46 [18.66]
330	33.0	2.013	166.6 [6.56]	96.6 [3.80]	9.12 [20.12]	139.1 [5.48]	70.6 [2.78]	8.69 [19.16]
380	38.0	2.318	171.8 [6.76]	99.2 [3.91]	9.38 [20.66]	144.3 [5.68]	73.2 [2.88]	8.93 [19.68]
440	44.0	2.684	178.0 [7.01]	102.3 [4.83]	9.67 [21.32]	150.5 [5.93]	76.3 [3.00]	9.21 [20.30]
500	50.0	3.050	184.2 [7.25]	105.4 [4.15]	9.96 [21.97]	156.7 [6.17]	79.4 [3.13]	9.49 [20.92]

A critical element which must be considered when specifying a W1500 pump for your application is the shaft drive system. Haldex has both the product and the application experience to insure that your W1500 pump incorporates the correct shaft for your application. The following depict the 9 standard shaft options for the W1500 family. Our flexible manufacturing capabilities can accommodate a wide variety of shaft configurations.

STRAIGHT SHAFT SAE "A" ORDER CODE BA

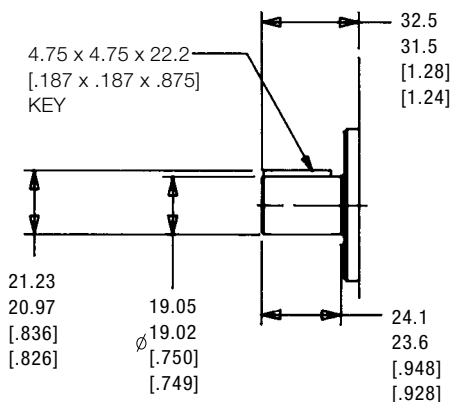

STRAIGHT SHAFT SAE "B" ORDER CODE DA

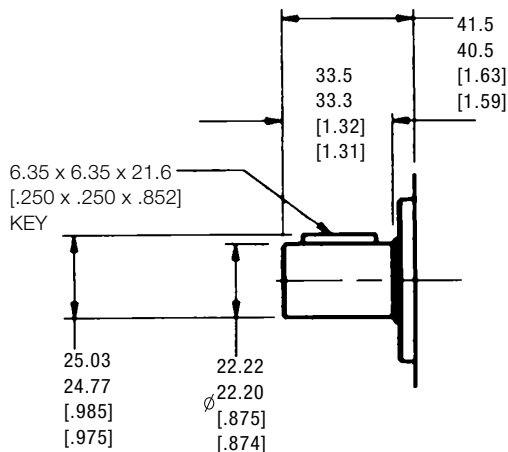

SAE "A" 9T SPLINE ORDER CODE FA

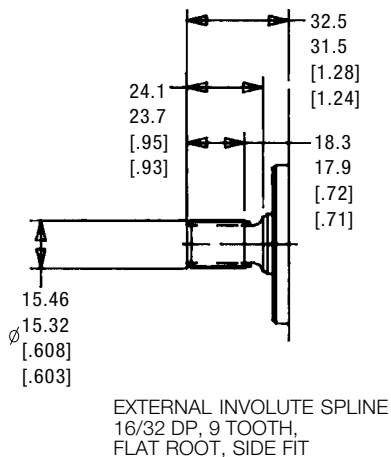

SAE "A" 11T SPLINE ORDER CODE GA

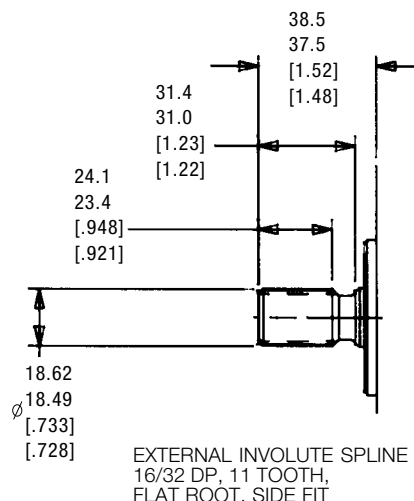

DIN 5480 14T SPLINE SHAFT ORDER CODE HA

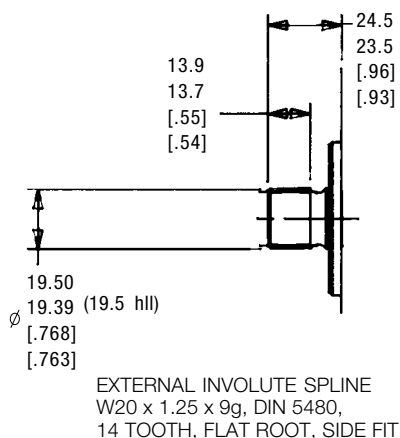

SAE "B" 13T SPLINE SHAFT ORDER CODE KA

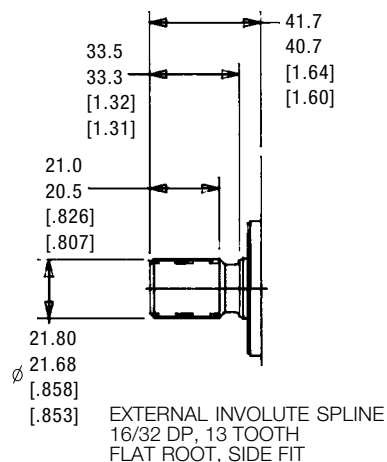

SHAFT OPTIONS

SAE "A" TAPERED (1:8) ORDER CODE LA

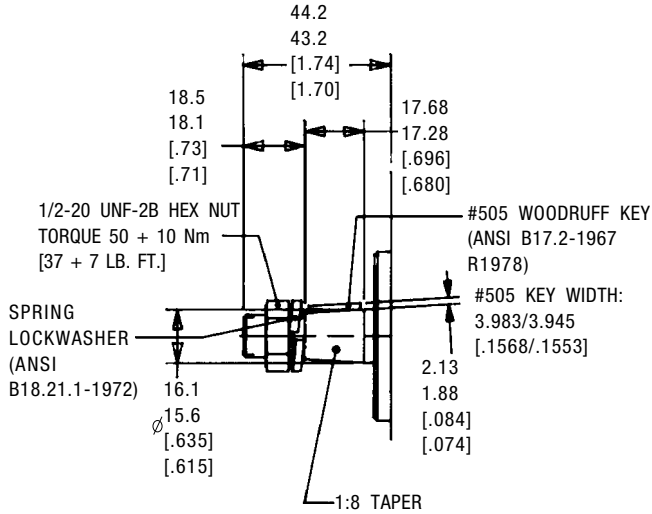

EUROPEAN TAPERED (1:5) ORDER CODE TB

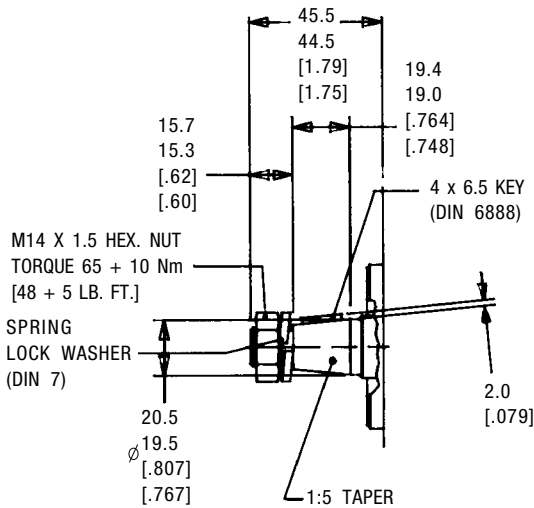

SAE "B" TAPERED (1:8) ORDER CODE UB

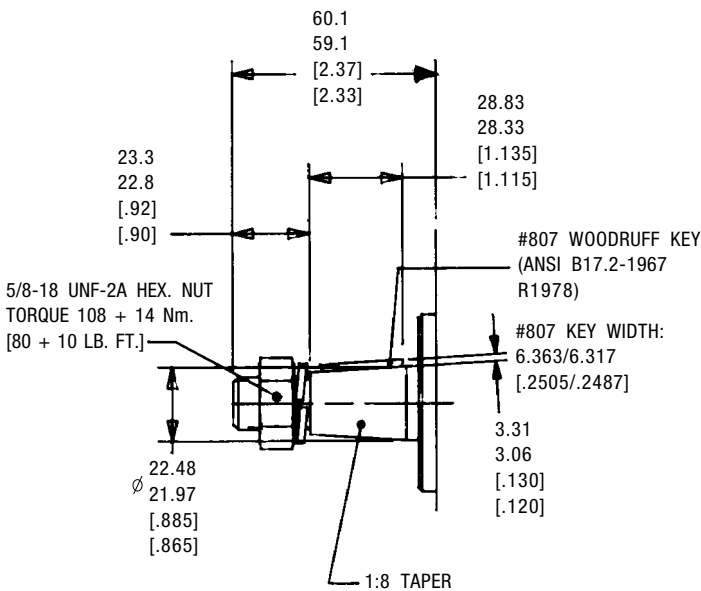

Key, washer and nut included with pump, where applicable.

SINGLE SECTION SHAFT LOADING

$$P \times V \leq \text{MAX PERMITTED VALUE IN TABLE BELOW}$$

WHERE:

P = PRESSURE (BAR)

V = DISPLACEMENT (CM³/REV)

WHERE:

P = PRESSURE (PSI)

V = DISPLACEMENT (IN³/REV)

CALCULATIONS USING METRIC UNITS	
SHAFT OPTION	MAX.PERMITTED VALUE
BA	10488
DA	20976
FA	5240
GA	9608
HA	11304
KA	18240
LA	8082
TB	20976
UB	16340

CALCULATIONS USING ENGLISH UNITS	
SHAFT OPTION	MAX.PERMITTED VALUE
BA	9257
DA	18564
FA	4640
GA	8508
HA	10004
KA	16142
LA	7506
TB	18564
UB	14461

MULTIPLE SECTION SHAFT LOADING

TWO SECTION:

$$(P1 \times V1) + (P2 \times V2) \leq \text{MAX. PERMITTED VALUE IN TABLE BELOW}$$

THREE SECTION:

$$(P1 \times V1) + (P2 \times V2) + (P3 \times V3) \leq \text{MAX. PERMITTED VALUE IN TABLE BELOW}$$

WHERE:

P1 = PRESSURE (BAR)

V = DISPLACEMENT (CM³/REV)

WHERE:

P1 = PRESSURE (PSI)

V = DISPLACEMENT (IN³/REV)

CALCULATIONS USING METRIC UNITS	
SHAFT OPTION	MAX.PERMITTED VALUE
BA	10488
DA	20976
FA	5240
GA	9608
HA	11304
KA	18240
LA	8082
TB	20976
UB	16340

CALCULATIONS USING ENGLISH UNITS	
SHAFT OPTION	MAX.PERMITTED VALUE
BA	9257
DA	18564
FA	4640
GA	8505
HA	10004
KA	16142
LA	7506
TB	18564
UB	14461

COUPLING LOADING

TWO SECTION:

$$(P2 \times V2) \leq 10488 \text{ (METRIC) } 9257 \text{ (ENGLISH UNITS)}$$

THREE SECTION:

$$(P2 \times V2) + (P3 \times V3) \leq 10488 \text{ (METRIC) } 9257 \text{ (ENGLISH UNITS)}$$

In multiple pumps, shaft end section must have largest displacement. Each consecutive section must have displacement equal to or smaller than section preceding.

SEE PAGES 3, 4, 8 & 9 FOR DIMENSIONS FROM FLANGE MOUNTING FACE TO PORT CENTERLINE.



The standard size for each type of port is outlined below.

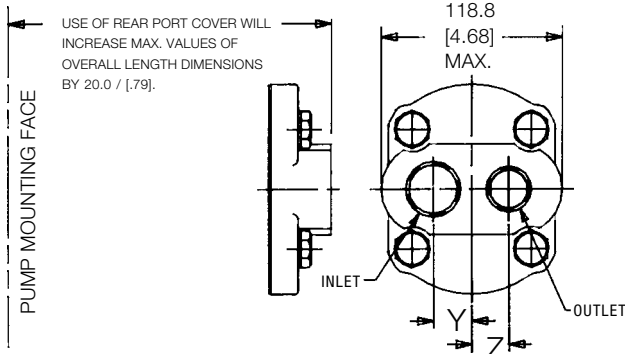

PUMP MAXIMUM SPEED IS REDUCED BELOW VALUES ON PAGE 2 WITH REAR INLET PORT, CONSULT FACTORY.

S.A.E. STRAIGHT THREAD PORT PER S.A.E. j514b						
DISP. ORDER CODE	SIDE PORT CODE	REAR PORT CODE	PORT SIZE INLET OUTLET	COUNTERBORE DIAMETER MIN.	Y ± 0.3 [± .012]	Z ± 0.3 [± .012]
190-250	103	503*	1-5/16-12 1-1/16-12	48.51 [1.910] 41.28 [1.625]	24.7 [.973]	23.6 [.929]
280-500	104	504*	1-5/8-12 1-5/16-12	57.66 [2.270] 48.51 [1.910]	29.1 [1.146]	26.2 [1.032]
BSPB STRAIGHT THREAD PORT PER DIN 3852, PART 2						
190-250	122	522*	G 1 G 3/4	40.0 [1.58] 33.0 [1.30]	22.6 [.890]	22.6 [.890]
280-500	123	523*	G 1-1/4 G 1	50.0 [1.97] 40.0 [1.58]	29.0 [1.142]	26.8 [1.055]

* 503 and 504 previously 103 and 104, respectively.
522 and 523 previously 122 and 123, respectively.

NOTE: Optional port sizes available on request. Contact factory.

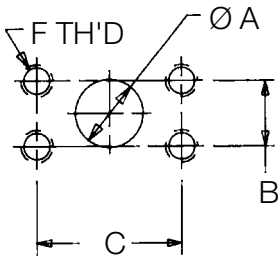

SEE PAGES 3, 4, 8 & 9 FOR DIMENSIONS FROM FLANGE MOUNTING FACE TO PORT CENTERLINE.

S.A.E. SPLIT FLANGE PER S.A.E. j518c (STANDARD PRESSURE SERIES)						
DISP. ORDER CODE	SIDE PORT CODE	PORT SIZE INLET OUTLET	Ø A	B	C	F TH'D X MIN. FULL TH'D DEPTH
190-250	141	[1.0] [3/4]	25.4 [1.00] 19.05 [.750]	26.19 [1.031] 22.22 [.875]	52.37 [2.062] 47.63 [1.875]	3/8-16 X 16 [.63] 3/8-16 X 16 [.63]
280-500	142	[1-1/4] [1.0]	31.8 [1.250] 25.4 [1.00]	30.18 [1.188] 26.19 [1.031]	58.72 [2.312] 52.37 [2.062]	7/16-14 X 16 [.63] 3/8-16 X 16 [.63]

METRIC SPLIT FLANGE PER ISO/DIS 6162 (35 to 350 BAR SERIES)						
DISP. ORDER CODE	SIDE PORT CODE	PORT SIZE INLET OUTLET	Ø A	B	C	F TH'D X MIN. FULL TH'D DEPTH
190-250	146	25 19	25.4 [1.00] 19.05 [.750]	26.19 [1.031] 22.22 [.875]	52.37 [2.062] 47.63 [1.875]	M10 X 1.5 X 16 [.63] M10 X 1.5 X 16 [.63]
280-500	147	32 25	31.75 [1.25] 25.4 [1.00]	30.18 [1.188] 26.19 [1.031]	58.72 [2.312] 52.37 [2.062]	M12 X 1.75 X 16 [.63] M10 X 1.75 X 16 [.63]

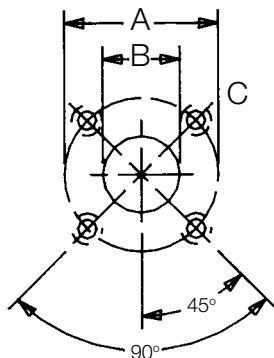

SEE PAGES 3, 4, 8 & 9 FOR DIMENSIONS FROM FLANGE MOUNTING FACE TO PORT CENTERLINE.

EUROPEAN 4-BOLT FLANGE					
DISP. ORDER CODE	SIDE PORT CODE	PORT SIZE INLET OUTLET	A Ø	B Ø	C TH'D X MIN. FULL TH'D DEPTH
190-500	151	26 18	55.0 [2.165] 55.0 [2.165]	26 [1.02] 18 [.71]	M8 X 1.25 X 13 [.51] M8 X 1.25 X 13 [.51]

W1500 MULTIPLE PUMPS

DOUBLE SECTION / DUAL INLET

The W1500 offers multiple pump configurations up to 4 sections. Multiple pumps provide multiple hydraulic functions from one power source at a significantly lower cost than separate pumps.

The drawings and charts provide dimensional information as well as shaft and coupling load information for W1500 two and three section pumps. If the shaft loading, coupling, and section sequence requirements outlined on page 6 are met, W1500 multiple pumps will exhibit the same performance as W1500 single section pumps outline on the cover of this catalog.

Please contact Haldex for assistance with your four section W1500 pump applications.

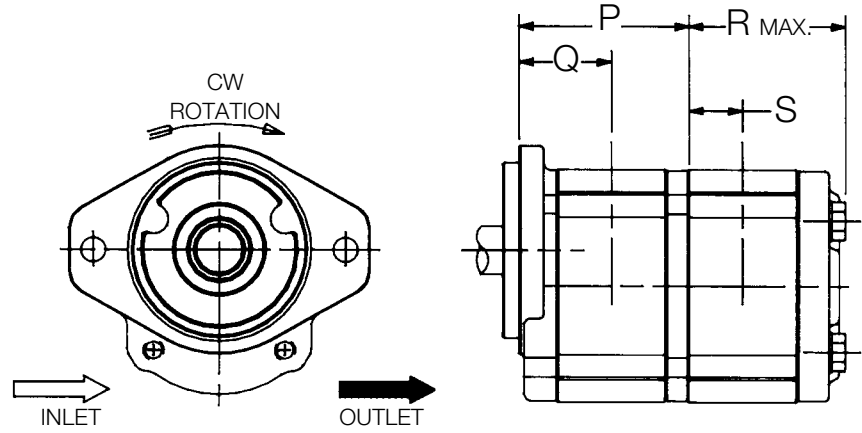

(For counterclockwise rotation, inlet and outlet are reversed.)

(Flange Option 05 shown.)

Dimensions P & Q are for use with Flange Options 05 & 08.

TRIPLE SECTION / TRIPLE INLET

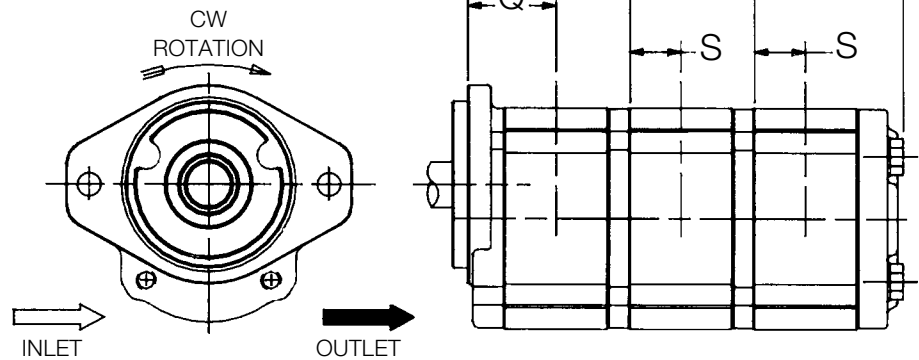

(For counterclockwise rotation, inlet and outlet are reversed.)

(Flange Option 05 shown.)

Order Code	Displacement		P ± 0.26 [+ .010]	Q (To Port Centerline)	Approx. Wt. P Section kg. [lbs.]	R Max.	S (To Port Centerline)	Approx. Wt. R Section kg. [lbs.]	T ± 0.26 [+ .010]	Approx. Wt. T Section kg. [lbs.]	N ± 0.26 [+ .010]	L (To Port Centerline)	Approx. Wt. N Section kg [lbs.]
	cm ³	in ³											
190	19.0	1.159	105.5 [4.154]	63.3 [2.49]	7.04 [15.53]	101.2 [3.99]	40.3 [1.58]	5.11 [11.26]	82.5 [3.248]	4.11 [9.07]	131.6 [5.181]	89.3 [3.52]	7.64 [16.85]
230	23.0	1.403	109.7 [4.319]	65.4 [2.57]	7.23 [15.95]	105.4 [4.15]	42.4 [1.66]	5.29 [11.67]	86.7 [3.414]	4.30 [9.47]	135.8 [5.346]	91.4 [3.60]	7.82 [17.24]
250	25.0	1.525	111.9 [4.406]	66.6 [2.62]	7.33 [16.16]	107.6 [4.24]	43.4 [1.70]	5.39 [11.88]	88.9 [3.500]	4.39 [9.68]	138.0 [5.433]	92.5 [3.64]	7.91 [17.44]
280	28.0	1.708	115.0 [4.528]	68.0 [2.68]	7.47 [16.46]	110.6 [4.36]	45.0 [1.76]	5.52 [12.17]	91.9 [3.619]	4.53 [9.98]	141.0 [5.551]	94.0 [3.70]	8.04 [17.73]
330	33.0	2.013	120.1 [4.729]	70.6 [2.78]	7.70 [16.97]	115.8 [4.56]	47.6 [1.87]	5.74 [12.66]	97.1 [3.823]	4.75 [10.46]	146.2 [5.756]	96.6 [3.80]	8.26 [18.21]
380	38.0	2.318	125.3 [4.934]	73.2 [2.88]	7.93 [17.48]	121.0 [4.76]	50.2 [1.97]	5.97 [13.16]	102.3 [4.028]	4.98 [10.97]	151.4 [5.961]	99.2 [3.91]	8.49 [18.70]
440	44.0	2.684	131.5 [5.178]	76.3 [3.00]	8.21 [18.11]	127.2 [5.01]	53.3 [2.09]	6.24 [13.77]	108.5 [4.272]	5.25 [11.57]	157.6 [6.205]	102.3 [4.83]	8.75 [19.29]
500	50.0	3.050	137.7 [5.422]	79.4 [3.13]	8.49 [18.72]	133.4 [5.25]	56.4 [2.21]	6.52 [14.37]	114.7 [4.516]	5.52 [12.18]	163.8 [6.449]	105.4 [4.15]	9.02 [19.88]

Dimensions N & L are for use with Flange Option 04.

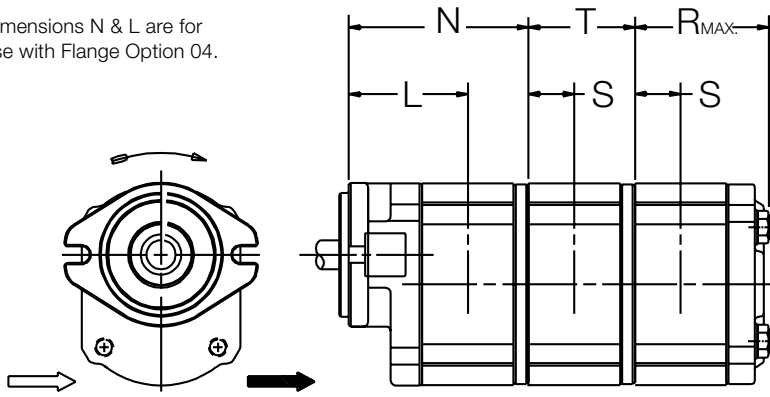

(Flange Option 04 shown.)

Consult factory for multiple pumps with more than two sections when using this flange.

REDUCED INLET MULTIPLE PUMPS

Based on your application requirements the W1500 multiple pump may be supplied with a single inlet on two section pump applications, dual inlets on three section pump applications and 3 inlets on four section applications. Reduced inlets provide overall system savings by reducing the cost of redundant inlet hose and fittings. Contact Haldex regarding your reduced inlet multiple pump application.

VALVE OPTIONS

See below for dimensional drawing and schematic of relief valve option for the W1500 pump.

OPTIONS	DESCRIPTION
EA	Cartridge Relief Valve, External To Tank - Side Ports
NN	None

SCHEMATIC

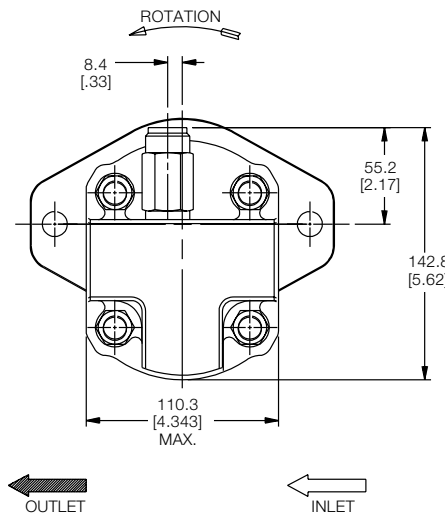
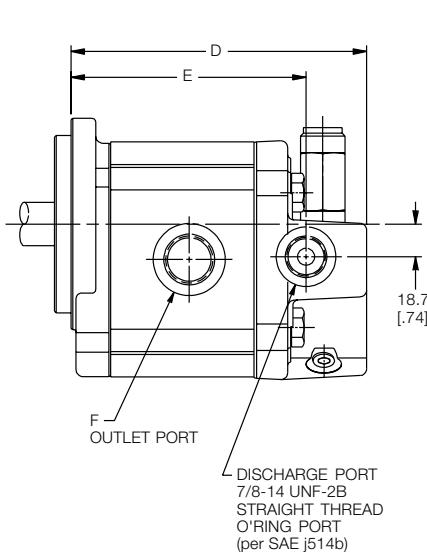
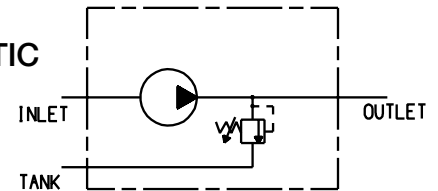

OPTION EA

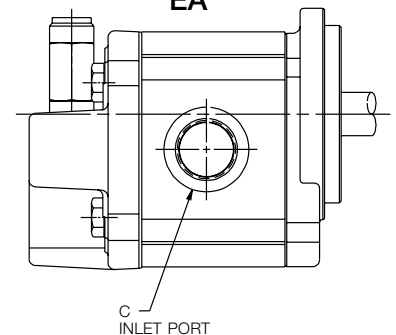

DISPLACEMENT CM ³ IN ³	C		D MAX.		E		F
	INLET PORT	FLANGE OPTION 04	FLANGE OPTIONS 05 & 08	FLANGE OPTION 04	FLANGE OPTIONS 05 & 08	FLANGE OPTION 04	OUTLET PORT
19.0 1.159	1-5/16-12	186.6 [7.35]	160.0 [6.30]	151.3 [5.96]	124.9 [4.92]	1-1/16-12	
23.0 1.403	1-5/16-12	190.8 [7.51]	164.2 [6.47]	155.5 [6.12]	129.1 [5.08]	1-1/16-12	
25.0 1.525	1-5/16-12	193.0 [7.60]	166.4 [6.55]	157.7 [6.21]	131.3 [5.17]	1-1/16-12	
28.0 1.708	1-5/8-12	196.0 [7.72]	169.4 [6.67]	160.7 [6.33]	134.3 [5.29]	1-5/16-12	
33.0 2.013	1-5/8-12	201.2 [7.92]	174.6 [6.88]	165.9 [6.53]	139.5 [5.49]	1-5/16-12	
38.0 2.318	1-5/8-12	206.4 [8.13]	179.8 [7.08]	171.1 [6.74]	144.7 [5.70]	1-5/16-12	
44.0 2.684	1-5/8-12	212.6 [8.37]	186.0 [7.32]	177.3 [6.98]	150.9 [5.94]	1-5/16-12	
50.0 3.050	1-5/8-12	218.8 [8.61]	192.2 [7.57]	183.5 [7.22]	157.1 [6.19]	1-5/16-12	

10 EXTERNAL SIDE & THRUST LOAD OPTIONS

The W1500 pump is recommended for direct axial drive. If your application incorporates a drive imposing radial and/or thrust loads, submit the application information requested below to your Haldex representative.

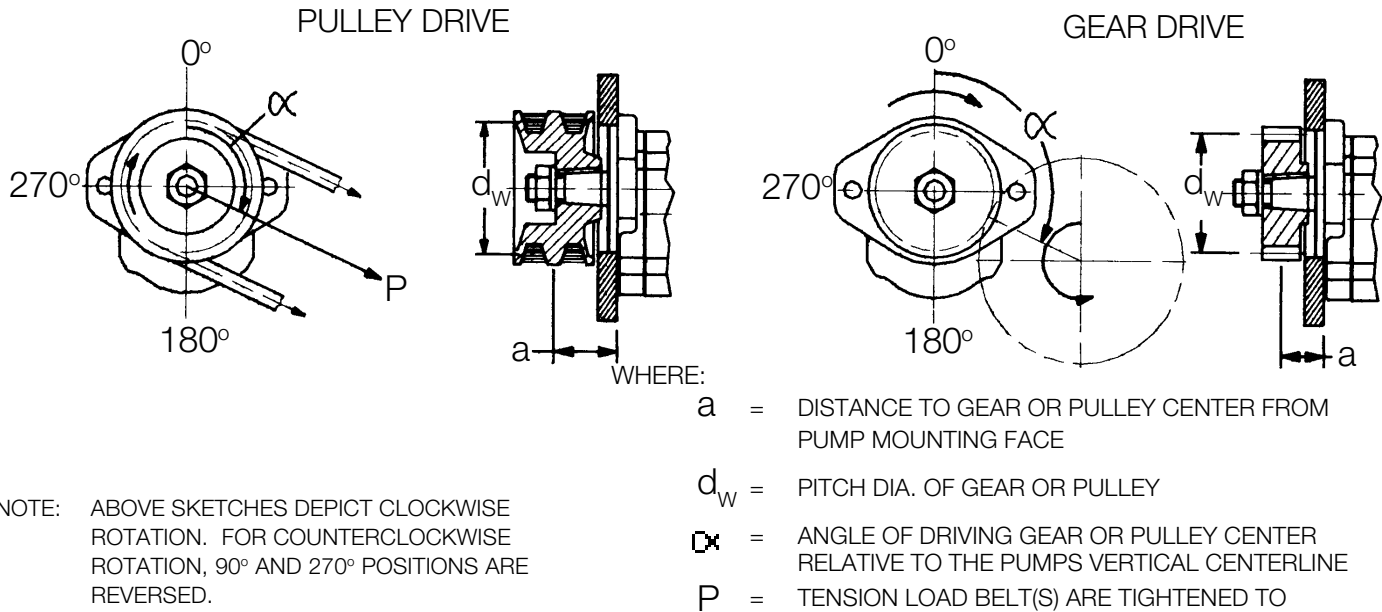

INSTALLATION INFORMATION

DIMENSIONS

Dimensions shown in brackets are in English units. Dimensions shown outside of brackets are metric units.

FLUIDS

Most premium grade petroleum base fluids can be used with W1500 pumps. Optimum operating viscosity is 16-40 cSt (74-185 SSU). Minimum operating viscosity is 10 cSt (59 SSU) at maximum rated pressure and maximum rated speed. Maximum operating viscosity is 750 cSt (3409 SSU). Maximum cold start viscosity is 2000 cSt (9240 SSU). Contact Haldex for additional information regarding the W1500 performance using other fluids.

OPERATING TEMPERATURES

Fluid temperature range:

Mineral Oil Max. 90°C (194°F) continuous
 Max. 105°C (221°F) intermittent

FILTRATION

Proper filtration is critical to the trouble free operation of any hydraulic system. For optimum pump life at maximum pressure ISO 4406/1986 (Code 18/14) is recommended. A 10-micron filter sized to accommodate full system return line flow is recommended for most operating environments.

INLET CONDITIONS

Inlet vacuum should not exceed 0.35 Bar below atmospheric pressure (10 In.Hg.). Continuous operation at vacuums in excess of 0.2 Bar below atmospheric pressure (6 In.Hg.) are not recommended. Max. gauge pressure for pressurized inlet conditions is 2.0 Bar (29 PSI).

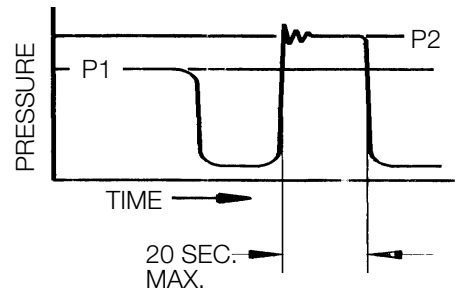

P1 - Continuous
 P2 - Intermittent

Total cycle for P2 is 30 seconds.

Above represents performance which can be expected from units incorporating flange port styles.

STANDARD PUMP												VALVE OPTIONS			
	1	2	3	3	3	4	5	6	7	7	7	8	9	10	11
	DESIGN CODE	SEAL MATERIAL	DISPLACEMENT	DISPLACEMENT	DISPLACEMENT	ROTATION	FLANGE	SHAFT	PORT	PORT	PORT	VALVE OPTION	VALVE TYPE	FLOW SETTING	RELIEF VALVE SETTING
EXAMPLE	WP15A3	B	380	380	230	R	04	BA	104	104	103	E	EA	NN	R35
Your Options	WP15A3												E*		

1. DESIGN CODE	WP15A1 - Single Pump	WP15A2 - Double Pump	WP15A3 - Triple Pump	WP15A4 - Quadruple Pump
-----------------------	----------------------	----------------------	----------------------	-------------------------

2. SEAL MATERIAL	B Buna	V Viton	C Combination of Both
-------------------------	--------	---------	-----------------------

3. DISPLACEMENT	OrderCode	Cm. ³	In. ³
	190	19	1.159
	230	23	1.403
	250	25	1.525
	280	28	1.708
	330	33	2.013
	380	38	2.318
	440	44	2.684
	500	50	3.050

4. ROTATION	R Clockwise	L Counter Clockwise	B Bi-Rotational (Case Drain)	C Bi-Rotational (Check Valves)
--------------------	-------------	---------------------	------------------------------	--------------------------------

5. MOUNTING FLANGES	04 SAE "A" 2-Bolt	05 SAE "B" 2-Bolt	08 Rectangular 3 (100.0 mm pilot, 88.4 x 132 mm bolt pattern) +
----------------------------	-------------------	-------------------	---

6. DRIVE SHAFTS	BA SAE "A" Straight Shaft 3/4" Dia.	DA SAE "B" Straight Shaft 7/8" Dia.	FA SAE "A" Spline (9 Tooth)	GA SAE "A" Spline (11 Tooth)	HA DIN 5480 Spline Shaft (W20 x 1.25 x 9g - 14T) +	KA SAE "B" Spline (13 Tooth)	LA SAE "A" Tapered (1:8)	TB European Tapered (1:5) (M14 Thread) +	UB SAE "B" Tapered (1:8)
------------------------	-------------------------------------	-------------------------------------	-----------------------------	------------------------------	--	------------------------------	--------------------------	--	--------------------------

7. STANDARD PORTING	DISP. ORDER CODE	SIDE PORT CODE	REAR PORT CODE	DESCRIPTION
	190-250	103	503*	SAE Straight Thread (1-5/16-12,1-1/16-12)
	280-500	104	504*	SAE Straight Thread (1-5/8-12,1-5/16-12)
	190-250	122	522*	BSPP Straight Thread (G1,G3/4)
	280-500	123	523*	BSPP Straight Thread (G1-1/4,G1)
	190-250	141	N/A	SAE Split Flange (1.0,3/4)
	280-500	142	N/A	SAE Split Flange (1-1/4,1.0)
	190-250	146	N/A	Metric Split Flange (25,19)
	280-500	147	N/A	Metric Split Flange (32,25)
	190-500	151	N/A	European 4-Bolt Flange (26,18)

* 503 and 504 previously 103 and 104, respectively.
522 and 523 previously 122 and 123, respectively.

Note: Above are standard offerings. For other porting options, please contact factory. Rear ports typically will not allow for catalog rated speeds.

8. VALVE OPTIONS	E Relief Valve with External Drain	N Not Applicable
-------------------------	------------------------------------	------------------

9. VALVE TYPE DESIGNATION	EA Relief Valve with External Drain	NN Not Applicable
----------------------------------	-------------------------------------	-------------------

10. FLOW CONTROL SETTINGS	NN Not Applicable
----------------------------------	-------------------

11. RELIEF VALVE SETTINGS	R** Relief pressure divided by 100. Available in 100 PSI increments to 4000 PSI. Example: R35 = 3500 PSI	NN Not Applicable
----------------------------------	--	-------------------

Note: Relief valve setting is defined at .25 GPM full bypass.

All pumps require a minimum 25-piece order with the exception of those options designated with "+" (100-piece minimum). A selected number of distributor stock pumps are available with no minimum order quantity. See list on opposite page.

Visit our website at <http://www.hbus.haldex.com>

Call Us Toll Free 1-800-572-7867

Email Us: info.hydraulics.us@haldex.com or info.hydraulics.eu@haldex.com



PRODUCT RANGE

He Powerpacks
12/24/48 VDC 0.8 – 3.5 kW and
0.75 – 3 kW AC modular power
packs

Pressure Switches
5 - 350 bar, connecting/
disconnecting

He Classic Power Packs
12/24/48 VDC modular
powerpacks in weatherproof
boxes

W100 Hydraulic pumps
0.5 – 2.0 cc 227 bar

W300 Hydraulic pumps
0.8 – 5.7 cc 230 bar

W600 Hydraulic pumps
4 – 12 cc/section 276 bar

WM600 Hydraulic motors
4 – 12 cc/section 276 bar

W900 Hydraulic pumps
5 – 31 cc/section 276 bar

WM900 Hydraulic motors
5 - 31 cc/section 276 bar

WQ900 The quiet pump
5 - 23 cc/section 230 bar

W1500 Hydraulic pumps
19 - 50 cc/section 276 bar

WM1500 Hydraulic motors
19 - 50 cc/section 276 bar

G25 Hydraulic pumps
23 – 87 cc/section 250 bar

GM25 Hydraulic motors
23 – 87 cc/section 250 bar

GPA Internal Gear pumps
1.7 – 63 cc/section 100 bar

GC Hydraulic pumps / fluid motors
1.06 – 11.65cc/section 276 bar

II-Stage Hydraulic pumps
4.2 – 22.8 cc/section 276 bar

Rotary Flow Dividers
3.8 – 13.3 cc/section 300 bar

D Hydraulic pumps
3.8 - 22.9 cc/section 207 bar

H Hydraulic pumps
9.8 - 39.4 cc/section 207 bar

G20/G30 Hydraulic pumps
23 – 161 cc/section 276 bar

GM20/GM30 Hydraulic motors
23 – 161 cc/section 276 bar

G20/G30 (LS) Hydraulic pumps
23 – 161 cc/section 276 bar

Transmission pumps

Fuel pumps

W1500 08 / 03

www.hbus.haldex.com



Haldex Hydraulics Corp.
2222 15th Street
ROCKFORD, IL 61104
USA
Tel: +1-815 398 4400
Fax: +1-815 398 5977
E-mail: info.hydraulics.us@haldex.com

Haldex Hydraulics Corp.
214 James Farm Road
Statesville, NC 28625
USA
Tel: +1-704 873 2587
Fax: +1-704 878 0530
E-mail: info.hydraulics.us@haldex.com

Haldex Hydraulics AB
Ringvägen 3, Box 95
SE-280 40 SKÅNES FAGERHULT
Sweden
Tel: +46-433 32400
Fax: +46-433 30546
E-mail: info.hydraulics.eu@haldex.com

Haldex Hydraulics AB
Industrigatan 6, Box 511
SE-195 25 ARLANDASTAD
Sweden
Tel: +46-8 591 288 50
Fax: +46-8 591 288 60
E-mail: info.hydraulics.eu@haldex.com

Haldex Hydraulics GmbH
Seligenweg 12, Postfach 15 07
DE-95014 HOF
Germany
Tel: +49-9281 895-0
Fax: +49-9281 87133
E-mail: info.hydraulics.eu@haldex.com

 Haldex is an innovator in vehicle technology supplying proprietary systems and components for trucks, cars and industrial vehicles, worldwide. With 4,100 employees and yearly sales exceeding 7 billion Swedish Kronor, Haldex is listed on the Stockholm Stock Exchange (www.haldex.com).