



HYDRAULIC MOTORS





Introduction to Haldex Hydraulic Motor Capability

Haldex offers one of the widest selections of gear pumps and hydraulic motors in the industry. All Haldex products are designed to provide solutions to our customers' application challenges. Haldex hydraulic motors are applied on turf care equipment, agricultural equipment, industrial sweepers, paving machinery, winches

and fan drives for a number of off-highway vehicles. They are specified by leading equipment manufacturers throughout the mobile equipment market.

The Haldex line of hydraulic motors covers a displacement range from .065 in.³ (1 cc) to 9.82 in.³ (161 cc). The

various series include cast iron fixed clearance, aluminum body pressure balanced, and cast iron pressure balanced designs. Both unidirectional and birotational configurations are available. Each series offers a large selection of shaft, flange and valve options to meet your application requirements.

Table of Contents

Series	Page
GC (Uni- or Birotational) Fixed Clearance Hydraulic Motors	3
WM600 (Uni- or Birotational) Pressure Balanced Hydraulic Motors	8
WM900 (Uni- or Birotational) Pressure Balanced Hydraulic Motors	15
WM1500 (Uni- or Birotational) Pressure Balanced Hydraulic Motors	22
H (Uni- or Birotational) Fixed Clearance Hydraulic Motors	30
GM20 (Unirotational) Pressure Balanced Hydraulic Motors	33
GM25 (Birotational) Pressure Balanced Hydraulic Motors	43
GM30 (Unirotational) Pressure Balanced Hydraulic Motors	34
Spindle Drive	50

Quick Reference Chart

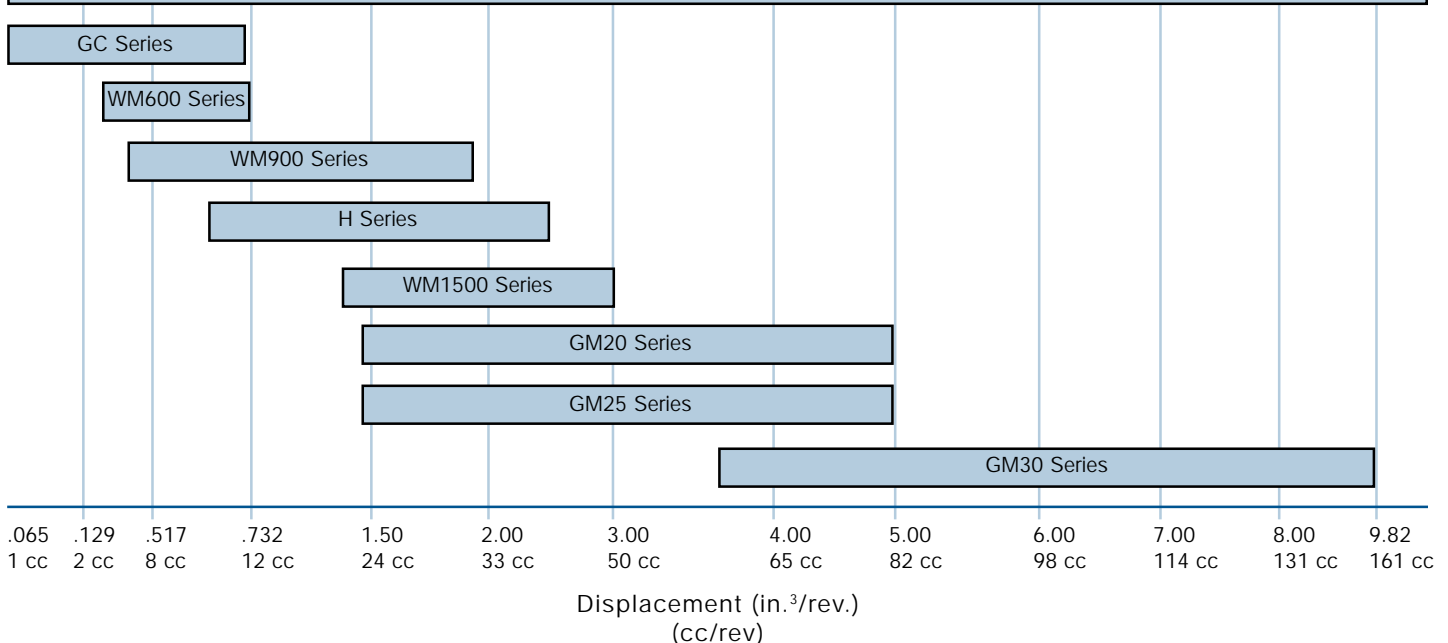

GC Series Hydraulic Motors



GC Series Hydraulic Motors are compact bidirectional external gear motors.

These motors feature cast iron bodies and needle bearings for long life under severe conditions. A variety of shaft,

flange and valve options can be specified on GC Series Motors. A unique feature of these motors is their high speed performance.

GC Series Hydraulic Motor Dimensions

See dimensional chart on top of page 4 for dimensions "A", "B", and "C" in drawings below.

4-Bolt Flange

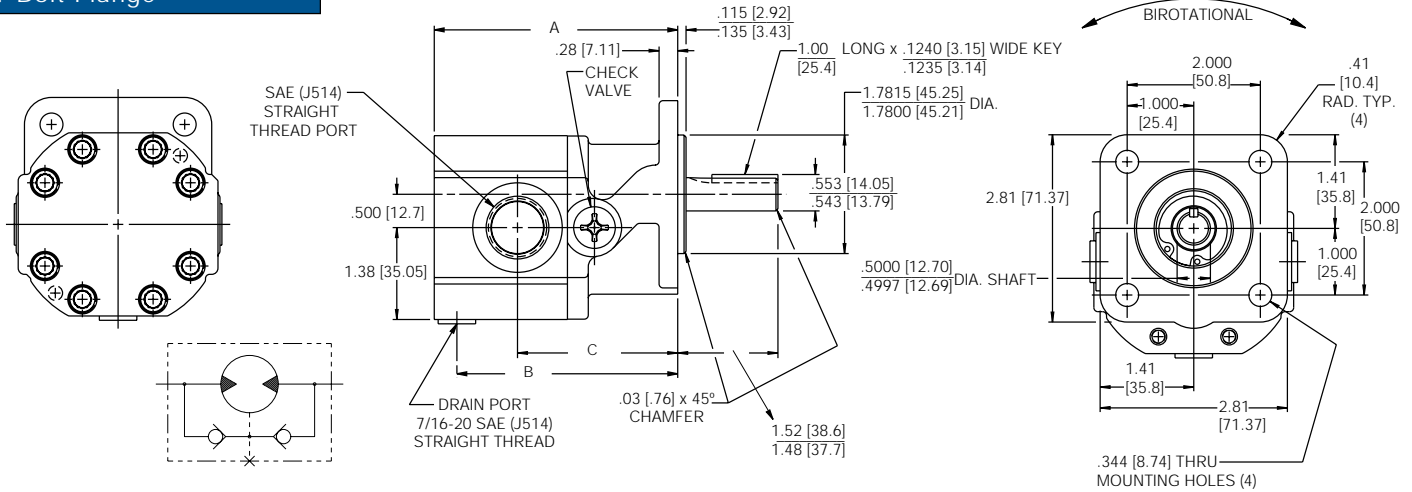

SAE "AA" 2-Bolt Flange

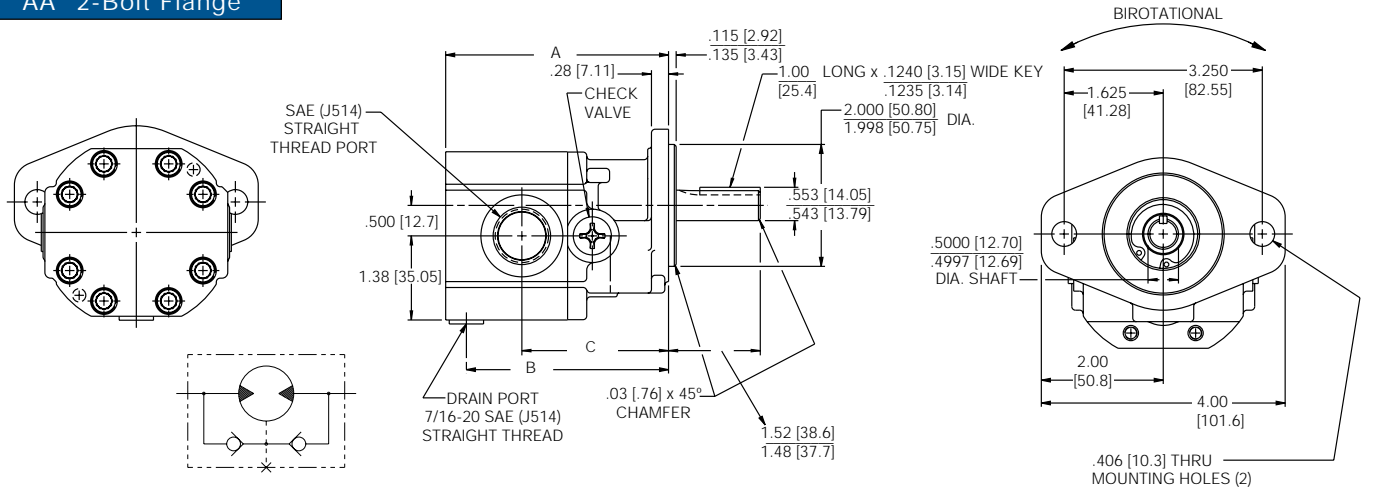

SAE "A" 2-Bolt Flange

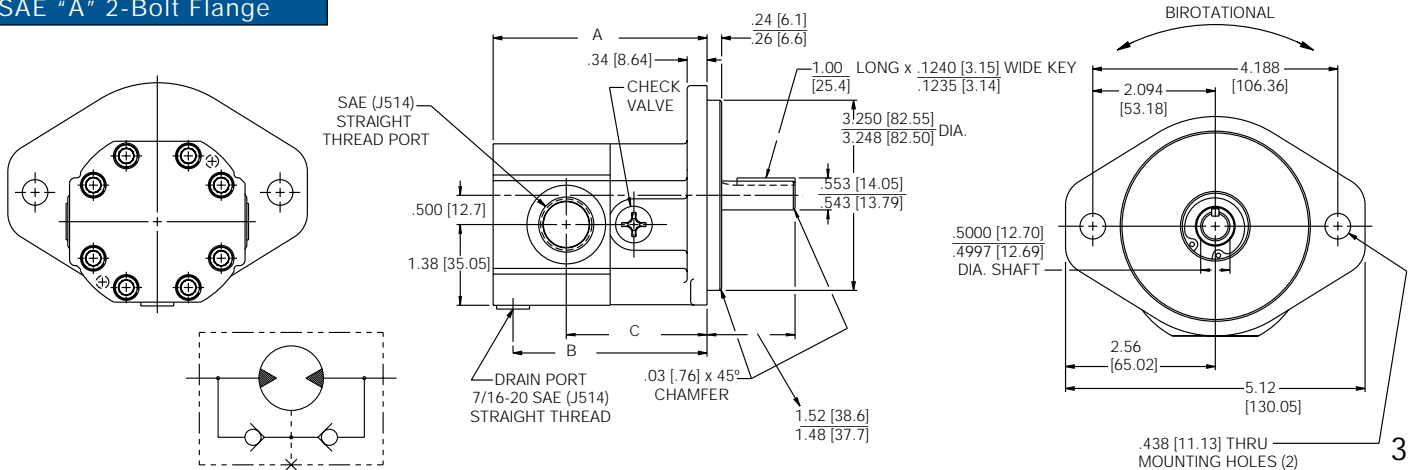



GC Hydraulic Motor Shaft Options

Dimensional chart below corresponds to dimensional drawings on page 3. Dimensions are inches [mm].

Order Code	A	B	C	Order Code	A	B	C	
04	3.16 [80.26]	2.82 [71.62]	2.41 [61.21]	18	3.66 [92.96]	3.32 [84.32]	2.41 [61.21]	
06				20				
08				24				
10				28				
12				32				
14				36	4.16 [105.66]	3.82 [97.02]	Inlet	Outlet
16				40			2.41	2.91
	44	[61.21]	[73.91]					

Extended Shaft

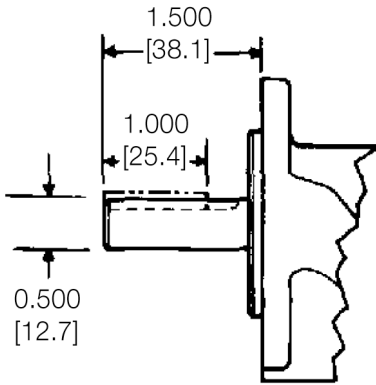

SAE "A" SPLINE Shaft

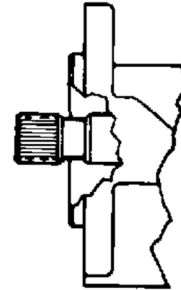

9T, 20/40 DP standard with 4-bolt and 2-bolt SAE "AA" flanges.
9T, 16/32 DP standard with 2-bolt SAE "A" flange.

Threaded Shaft

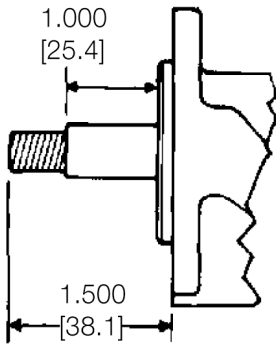

GC Hydraulic Motor Seal & Bearing Options

Five (5) basic seal and bearing configurations are available as shown here. Oil seals are either Buna-N or Viton. Outboard ball bearings are available for belt or gear drives and thrust loads. See PV factors (bottom of page 5) for seal ratings.

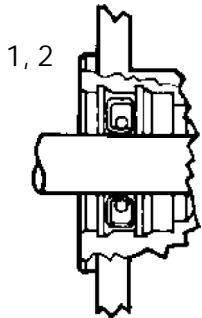

1, 2
SINGLE LIP
LOW PRESSURE SEAL

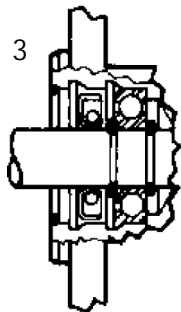

3
HIGH PRESSURE SEAL
WITH OUTBOARD BEARING
FOR THRUST LOAD

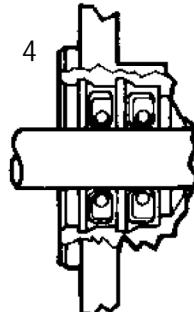

4
DOUBLE SEAL WITH
OVERBOARD DRAIN

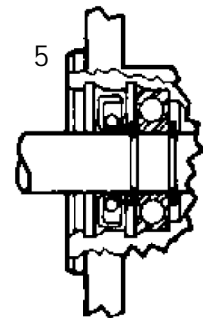

5
SEAL WITH OUTBOARD
BEARING FOR BELT
OR GEAR DRIVE

GC Hydraulic Motor Radial Loads



MAXIMUM FLUID MOTOR RADIAL LOADS

(without outboard ball bearing)

Clockwise Rotation

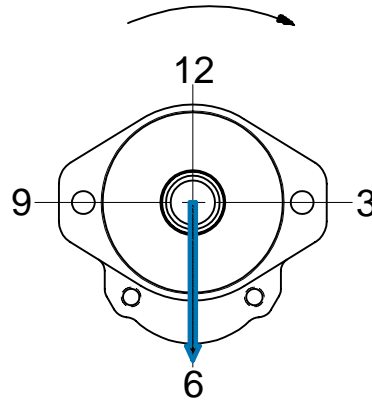

Pressure		Max. Radial Load at 6 O'Clock	
PSI	BAR	LBS	N
0-1000	0-69	10	44

For all other angles, consult factory.

GC Hydraulic Motor Shaft Seal Capabilities

To insure that the performance capabilities of the shaft seal are not exceeded, use the chart below. Multiply as follows: (PV Factor = PSI x Shaft Dia. (in.) x π (3.1415926) x RPM. Take this value and \div by 12 in./ft.). This figure must not exceed the Pressure / Velocity factor shown in column 4. Outlet pressure on a uni-directional motor or case drain pressure on a bi-rotational motor must not exceed seal pressure ratings.

Description	Max. Seal Pressure PSI (Bar)	Temp. Range °F (°C)	PV Factor (psi-fpm)
Standard Buna	10 (.7)	-65 to 225 (-54 to 107)	N/A
Standard Viton	10 (.7)	-40 to 400 (-40 to 204)	N/A
High Pressure Viton	25 (1.7) @ 3000 RPM 38 (2.6) @ 2000 RPM	-40 to 350 (-40 to 177)	10000



GC Hydraulic Motor Valve Options

The schematic drawings shown below illustrate standard valve options offered on the GC hydraulic motors.

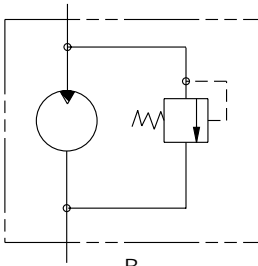

B
Inlet Relief Valve

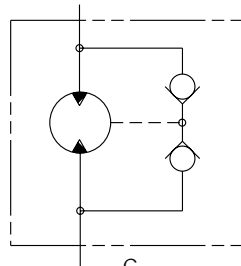

C
Bi-Rotational Check Valves

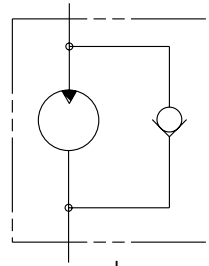

I
Overrunning Check Valve

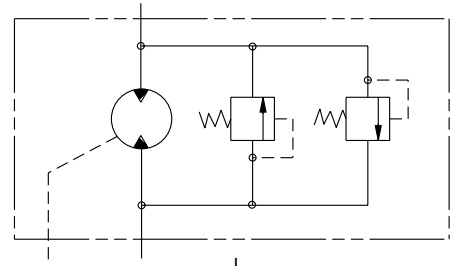

J
Cross Over Relief Valves w/Case Drain

OPTIONS	DESCRIPTION
B	Inlet Relief Valve
C	Bi-Rotational Check Valves
I	Overrunning Check Valve
J	Cross-Over Relief Valves w/Case Drain
N	None

GC Performance Curves @ 100 SSU

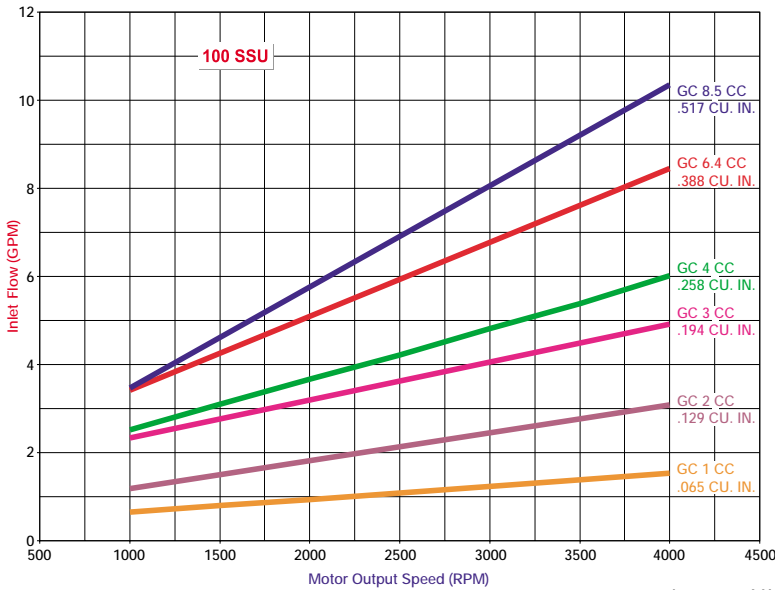

Inlet Flow vs. Output Motor Speed @ Max. Pressure



Pressure vs. Torque @ Max. Speed

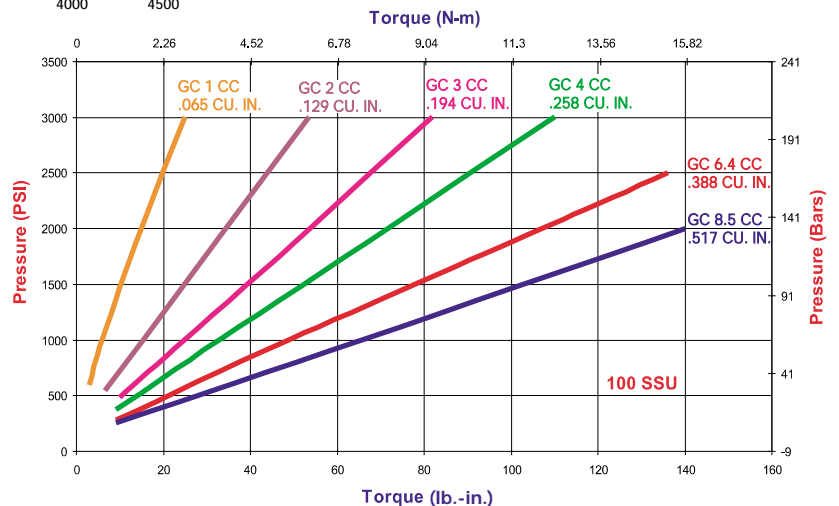

Installation Information



FLUIDS - Most premium grade petroleum base fluids can be used with GC Motors. Optimum operating viscosity is 16-63 cSt (80-288 SSU) at maximum rated speed. Minimum operating viscosity is 10 cSt (59 SSU). Maximum operating viscosity is 750 cSt (3409 SSU). Maximum cold start viscosity is 2000 cSt (9091 SSU). Contact us for additional information regarding the GC performance using other fluids.

OPERATING TEMPERATURES -

Fluid temperature range (Mineral Oil):
Max. 93°C (200°F) continuous and
Max. 105°C (221°F) intermittent.

FILTRATION - Proper filtration is critical to the trouble free operating of any hydraulic system. For optimum motor life at maximum pressure ISO 4406/1986 (Code 18/14) is recommended. A 10-micron filter sized to accommodate full system return flow is recommended for most operating environments.

GC Series Hydraulic Motor Order Code

Each GC Series Motor option has been assigned an order code which is listed in the tables below. Configure the desired options as shown in the example model code to the right.

	1	2	3	4	5	6	7	8	9	10
	DESIGN CODE	MOUNTING FLANGE	SHAFT	DISPLACEMENT	VALVING	SEALS & BEARINGS	PORTING	ROTATION	CASE DRAIN	RELIEF VALVE SETTING
EXAMPLE	GCM	2	2	08	B	1	A	1	A	10
Your Options	GCM									

2. **MOUNTING FLANGE**

1	4-Bolt w/ 1.78" Pilot
2	2-Bolt SAE "AA" w/ 2.0" Pilot
4	2-Bolt SAE "A" w/ 3.25" Pilot

3. **DRIVE SHAFTS**

2	0.50" Dia. x 1.50" Ext., 1/8" Sq. Key
4*	Threaded End (Specify Thread)
5	SAE Spline (9 Tooth) - 20/40DP standard with flange options 1 and 2; - 16/32DP standard for flange option 4

- 100-piece minimum order

4. **DISPLACEMENT**

Order Code	In. ³	CC
04	.065	1.06
06	.097	1.58
08	.129	2.11
10*	.161	2.63
12	.194	3.17
14*	.226	3.70
16	.258	4.22
18*	.291	4.76
20	.323	5.29
24	.388	6.35
28	.453	7.42
32	.517	8.47
36	.581	9.52
40	.647	10.60
44	.711	11.65

- 100-piece minimum order

5. **VALVE OPTIONS**

B	Inlet Relief Valve
C	Bi-Rotational Check Valves
I	Overrunning Check Valve
J	Cross-Over Relief Valves w/Case Drain
N	None

6. **SEAL & BEARING OPTIONS**

1	Single Lip Buna-N Low Pressure Seal
2	Viton Seal
3*	Viton High-Pressure Seal w/Outboard Ball Bearing
4*	Double Seal w/Overboard Drain
5*	Buna-N Seal w/Outboard Ball Bearing

- 100-piece minimum order
- * Not available with shaft option 3

7. **PORT LOCATION OPTIONS**

A	SAE Side Ports
B*	SAE Rear Ports
C*	NPTF Side Ports
D*	NPTF Rear Ports
E*	Inlet Tube, 1.0" Dia. w/ SAE Side Outlet Port

NOTE: If ordering NPTF Ports, specify size: 1/4", 3/8" or 1/2".

- 100-piece minimum order

8. **ROTATION**

1	Clockwise
2	Counter Clockwise
3*	Berotational

* Must specify Option "C", "J" or "A" in Valve Options.
Option "A" is for case drain.

9. **CASE DRAIN**

A	Case Drain
N	None

10. **RELIEF VALVE SETTINGS**

02-40	Full bypass pressure in hundreds of PSI. (Example: 00 = No Relief; 09 = 900 PSI (Full Bypass Pressure); 40 = 4000 PSI (Full Bypass Pressure))
-------	---

Note: The maximum relief valve full bypass setting for each gear size as listed on page 2 of GC Series Pump Catalog, "intermittent rating" pressure chart.

Minimum full bypass relief valve settings:
200 PSI for gear sizes 04 - 16 at 1725 RPM,
300 PSI for gear sizes 18 - 44 at 1725 RPM.
At speeds above 1725 RPM, the minimum relief valve settings increase. Contact factory for specific information.



W SERIES HYDRAULIC MOTORS

W Series motors are available in 3 families with displacements ranging from .183 in.³ to 3.05 in.³ (3 cc to 50 cc). W Series motors are available in both unirotational or birotational configurations. All feature a three-piece bushing block design for high pressure operation. A number of shaft and flange combinations are available. Integral valve options provide ease of system design. A key feature of all motors in the W Series is the extremely high volumetric efficiency.

WM600 Flange Options

SAE "AA" 2-BOLT ORDER CODE 02 (Dry Mount) / ORDER CODE 22 (Wet Mount)

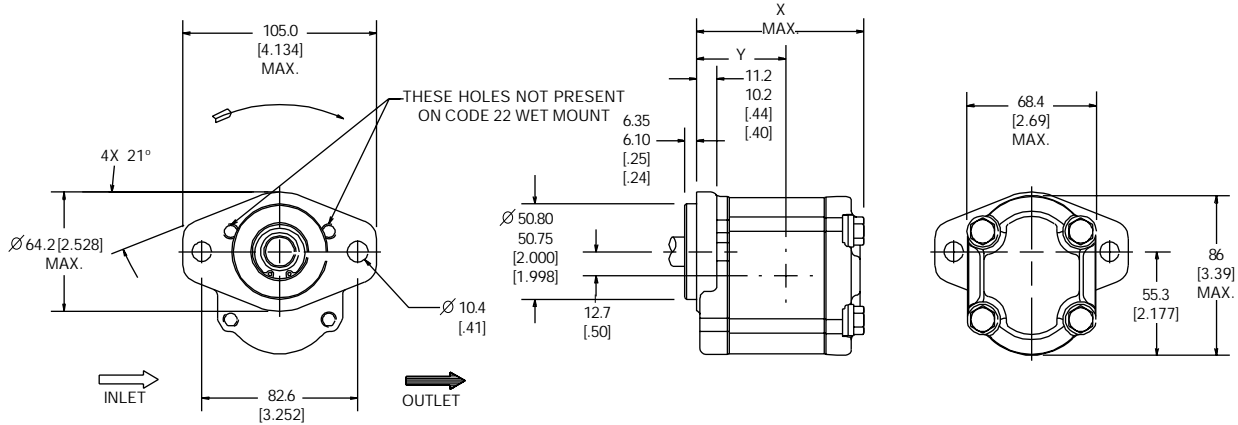

SAE "A" 2-BOLT ORDER CODE 03 (Dry Mount) / ORDER CODE 33 (Wet Mount)

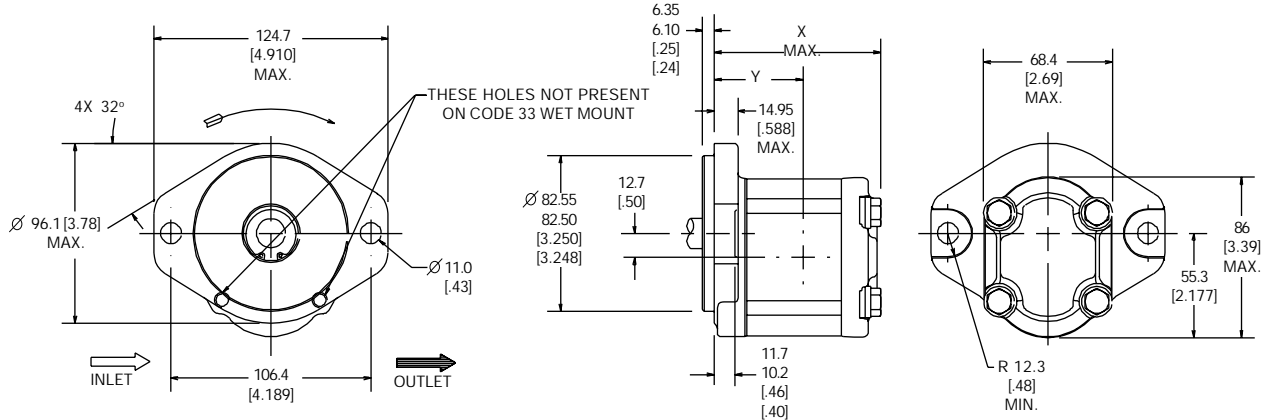

WM600 Dimensions & Weights

(See dimensional drawings above.)

Order Code	Displacement		X Max.		Y Port		Approx. Wt.
	cm ³	in ³	(2-Bolt)	(4-Bolt)	(2-Bolt)	(4-Bolt)	kgs. (lbs.)
040	4.0	.244	82.5 [3.25]	106.4 [4.19]	44.4 [1.75]	68.4 [2.69]	2.48 [5.45]
045	4.5	.275	83.9 [3.30]	107.8 [4.24]	47.3 [1.86]	71.3 [2.81]	2.50 [5.5]
050	5.0	.305	85.3 [3.36]	109.3 [4.30]	47.3 [1.86]	71.3 [2.81]	2.53 [5.6]
060	6.0	.366	89.1 [3.51]	113.0 [4.45]	47.3 [1.86]	71.3 [2.81]	2.58 [5.7]
070	7.0	.427	92.2 [3.63]	115.1 [4.53]	47.3 [1.86]	71.3 [2.81]	2.63 [5.8]
080	8.0	.488	96.4 [3.80]	120.3 [4.74]	47.3 [1.86]	71.3 [2.81]	2.68 [5.9]
100	10.0	.610	99.9 [3.93]	123.8 [4.87]	49.0 [1.93]	73.0 [2.87]	2.78 [6.1]
120	12.0	.732	105.8 [4.17]	129.7 [5.11]	52.0 [2.05]	76.0 [2.99]	2.88 [6.3]

WM600 Shaft Options



STRAIGHT KEYED SHAFT SAE "AA" ORDER CODE AA

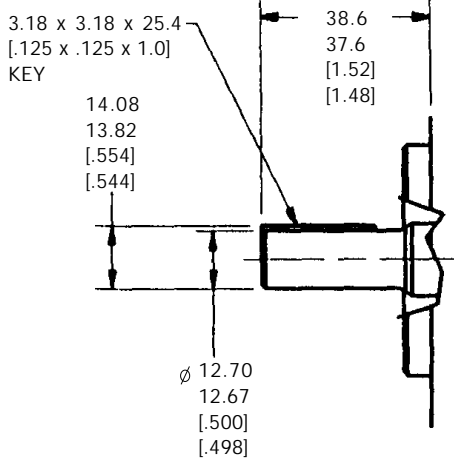

5/8 " STRAIGHT KEYED SHAFT SAE "A" ORDER CODE CA

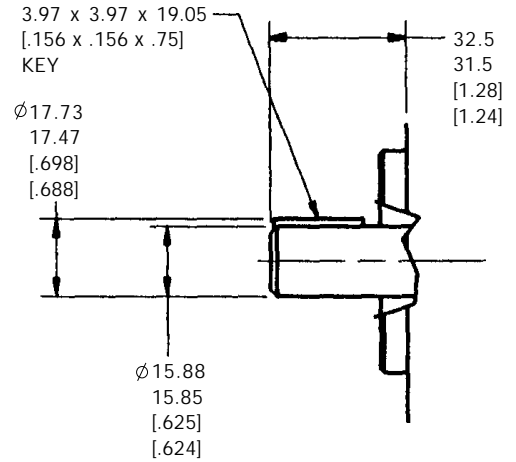

SAE "AA" SPLINE ORDER CODE EA

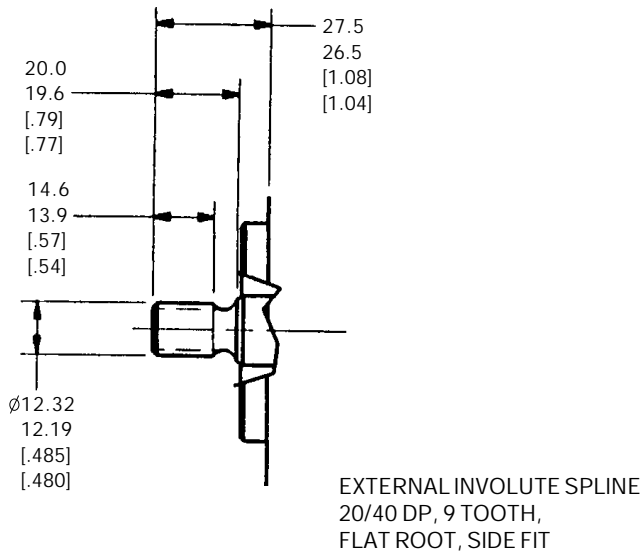

SAE "A" SPLINE ORDER CODE FA

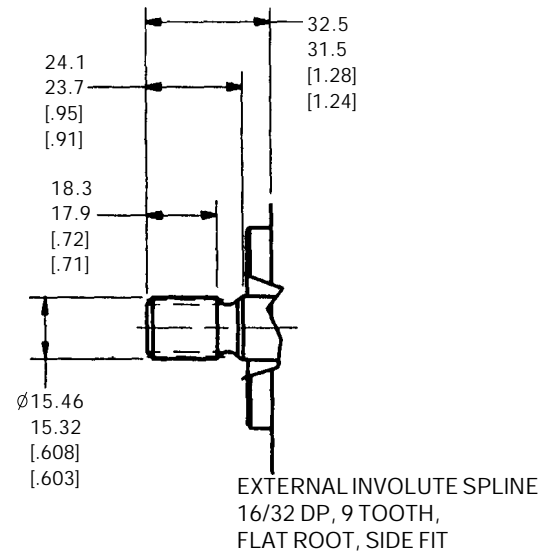

SAE "A" TAPERED SHAFT ORDER CODE LA

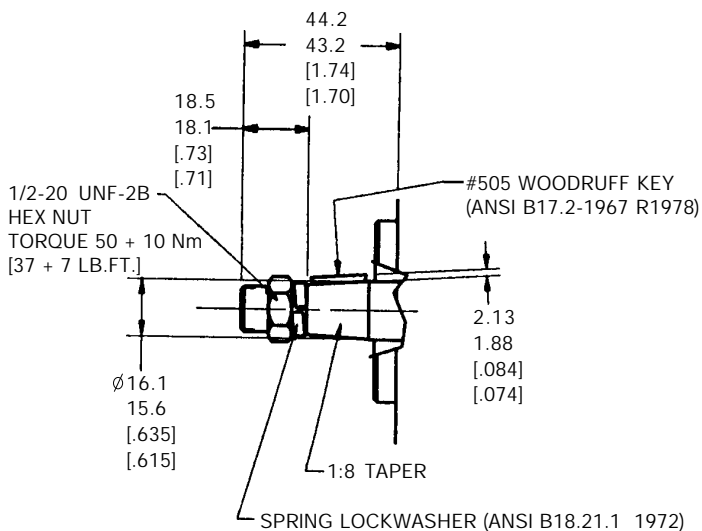



WM600 Axial/Radial Loads

MAXIMUM FLUID MOTOR AXIAL LOADS

- MAX. 400 N. (90 LBS.) AT VISCOSITY OF 10 CST (59 SSU) (BOTH DIRECTIONS)
- THE RESULTANT LOAD FROM THE AXIAL AND RADIAL FORCES MUST BE LESS THAN 600 N. (135 LBS.).

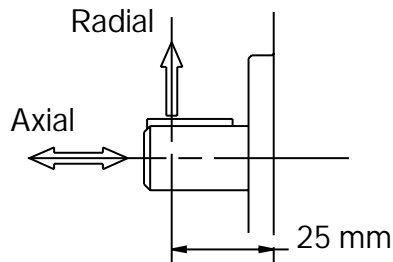

MAXIMUM FLUID MOTOR RADIAL LOADS

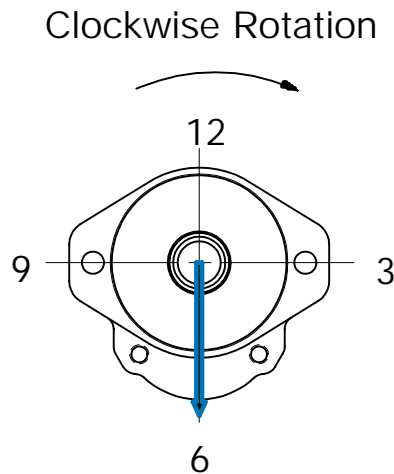

Pressure		Max. Radial Load at 6 O'Clock	
PSI	BAR	LBS	N
0-3500	0-241	130	578

For all other angles, consult factory.

WM600 Shaft Seal Capabilities



To insure that the capabilities of the shaft seal are not exceeded, use the chart below. Outlet pressure on a uni-directional motor or case drain pressure on a bi-rotational motor must not exceed seal pressure ratings.

Description	Max. Pressure PSI (Bar)	Temp. Range °F (°C)
Standard Buna	44 (3)	-31 to 248 (-35 to 120)
Standard Viton	44 (3)	-31 to 300 (-35 to 149)

WM600 Performance Curves @ 100 SSU

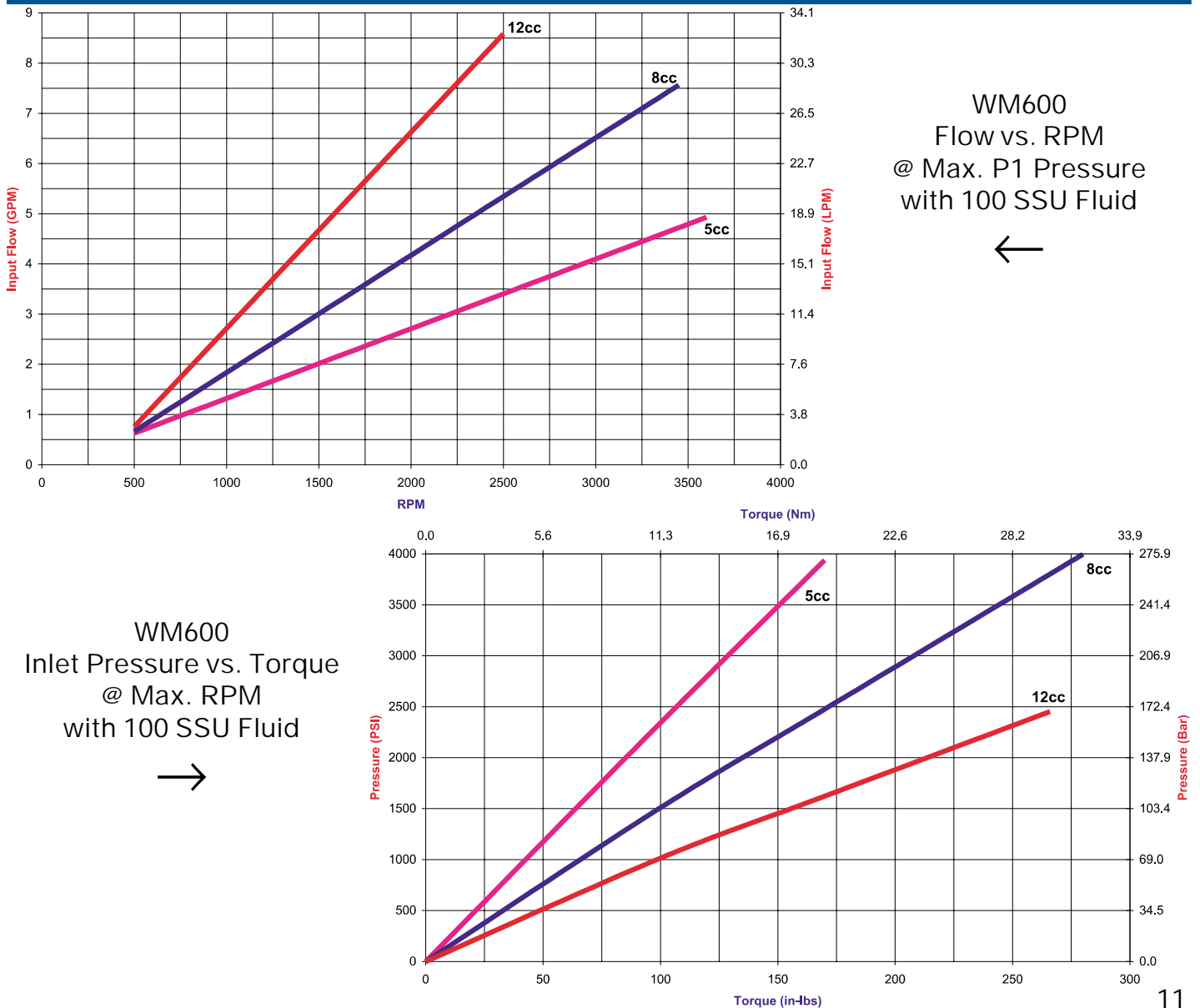



WM600 Case Drain

Case drain leakage is less than 0.38 LPM (.1 GPM) with 20.6 cSt (100 SSU) fluid.

Installation Information

FLUIDS - Most premium grade petroleum base fluids can be used with WM600 Motors. Optimum operating viscosity is 16-63 cSt (80-288 SSU) at maximum rated speed. Minimum operating viscosity is 10 cSt (59 SSU). Maximum operating viscosity is 750 cSt (3409 SSU). Maximum cold start

viscosity is 2000 cSt (9091 SSU). Contact Haldex for additional information regarding the W600 performance using other fluids.

OPERATING TEMPERATURES - Fluid temperature range (Mineral Oil): Max. 93°C (200°F) continuous and Max. 105°C (221°F) intermittent.

FILTRATION - Proper filtration is critical to the trouble free operating of any hydraulic system. For optimum motor life at maximum pressure ISO 4406/1986 (Code 18/14) is recommended. A 10-micron filter sized to accommodate full system return flow is recommended for most operating environments.

WM600 Valve Options

The schematic drawings shown below illustrate standard valve options offered on the WM600 hydraulic motors.

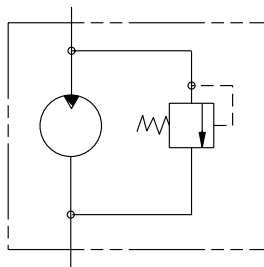

FC
Inlet Relief
Valve

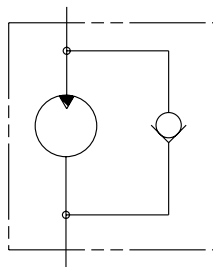

GE
Overrunning
Check Valve

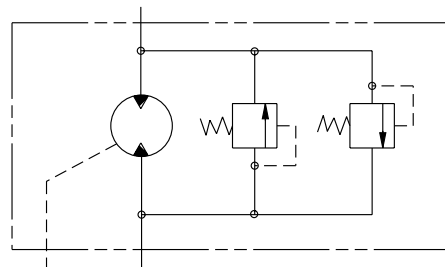

FD
Cross Over
Relief Valves
w/Case Drain

OPTIONS	DESCRIPTION
FC	Inlet Relief Valve
GE	Overrunning Check Valve
FD	Cross-Over Relief Valves w/Case Drain

WM600 Valve Option Dimensions



The drawings below depict the overall dimensions for the valve options specified on page 12.

RELIEF VALVE, CW ROTATION

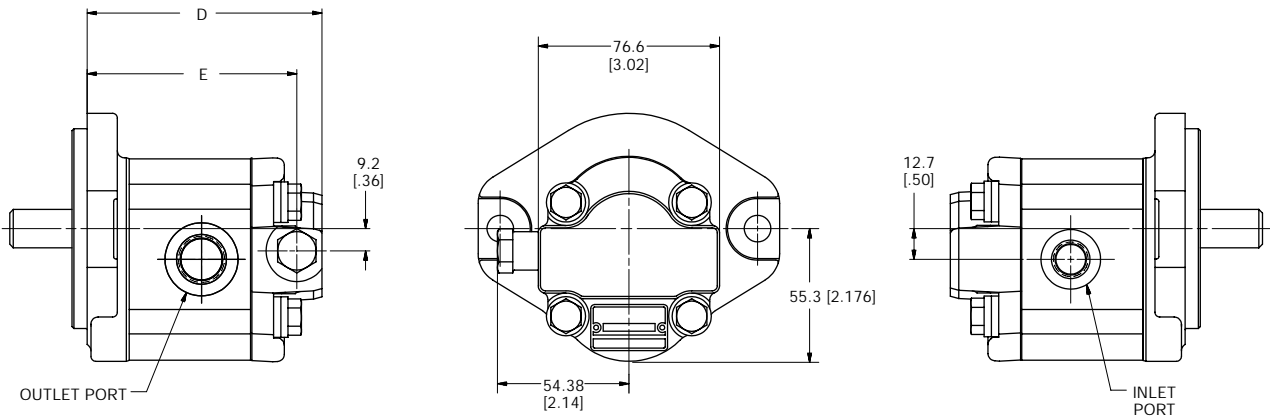

OVER-RUNNING CHECK, CW ROTATION

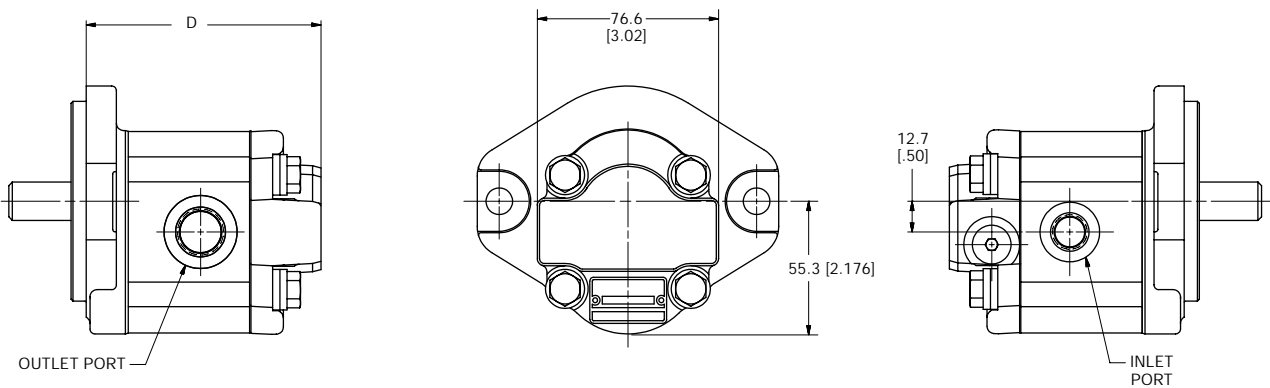

CROSS-OVER RELIEFS, CW ROTATION

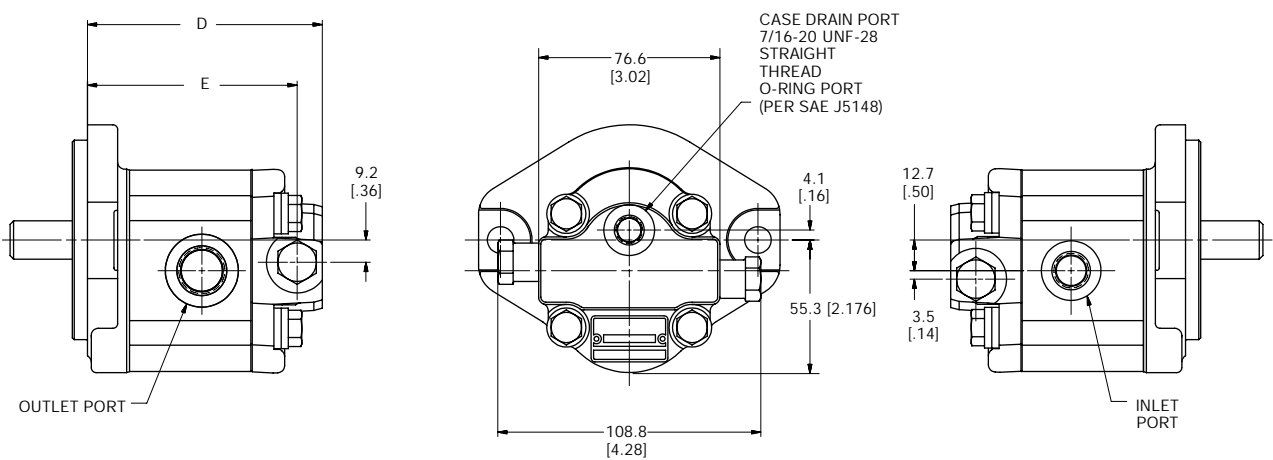

DISPLACEMENT		D MAX.		E	
cm ³	in ³	mm	in	mm	in
4.0	1.159	93.76	[3.69]	82.57	[3.25]
4.5	1.403	95.16	[3.75]	83.97	[3.31]
5.0	1.525	96.66	[3.81]	85.47	[3.36]
6.0	1.708	99.56	[3.92]	88.37	[3.48]
7.0	2.013	102.5	[4.03]	91.27	[3.59]
10.0	2.318	111.2	[4.38]	99.97	[3.94]
12.0	2.684	117.1	[4.61]	105.9	[4.17]



WM600 Hydraulic Motor Order Code

Each WM600 Series Motor option has been assigned an order code which is listed in the tables below. Configure the desired options as shown in the example model code to the right.

STANDARD MOTOR									
	1	2	3	4	5	6	7	8	9
	DESIGN CODE	SEAL MATERIAL	DISPLACEMENT	ROTATION	FLANGE	SHAFT	PORT	VALVE OPTION	RELIEF VALVE SETTING
EXAMPLE	WM06A1	B	100	R	02	EA	101	FC	R35
Your Options	WM06A1								

2. SEAL MATERIAL

B	Buna
V	Viton
C	Combination of Both

3. DISPLACEMENT

Order Code	Cm. ³	In. ³
040	4	.244
045	4.5	.275
050	5	.305
* 060	6	.366
* 070	7	.427
* 080	8	.488
* 100	10	.610
* 120	12	.732

* Case drain port is required for displacements 6-12 cc.

4. ROTATION

B	Birotational (Case Drain)
C	Birotational (Check Valves)
R	Clockwise (No Case Drain)
E	Clockwise (With Case Drain)
L	Counter Clockwise (No Case Drain)
W	Counter Clockwise (With Case Drain)

5. MOUNTING FLANGES

02	SAE "AA" 2-Bolt (Dry Mount)
03	SAE "A" 2-Bolt (Dry Mount)
22	SAE "AA" 2-Bolt (Wet Mount)
33	SAE "A" 2-Bolt (Wet Mount)

6. DRIVE SHAFTS

AA	SAE "AA" Straight Shaft 1/2" Dia.
CA	SAE Straight Shaft 5/8" dia.
EA	SAE "AA" Spline (9 Tooth)
FA	SAE "A" Spline (9 Tooth)
LA	SAE "A" Tapered (1:8)

7. STANDARD PORTING

DISP. ORDER CODE	SIDE PORT CODE	REAR PORT CODE	DESCRIPTION
040-120	101	501	SAE Straight Thread (7/8-14, 3/4-16)
040-120	120	520	BSPP Straight Thread (G1/2, G3/8)
040-120	150	N/A	European 4-Bolt Flange (20,15)

Note: Above are standard offerings. For other porting options, please contact factory.

8. VALVE OPTIONS

FC	Inlet Relief Valve
GE	Overrunning Check Valve
FD	Cross-Over Relief Valves with Case Drain
N	Not Applicable

9. RELIEF VALVE SETTINGS

R**	
**	Relief pressure divided by 100. Available in 100 PSI increments to 4000 PSI. Example: R35 = 3500 PSI
NN	Not Applicable

Note: Relief valve setting is defined at .25 GPM full bypass.

All motors require a minimum 25-piece order with the exception of those options designated with "+" (100-piece minimum). A selected number of distributor stock motors are available with no minimum order quantity.

The right to modification for technical improvements is reserved. Printed in USA.

WM900 Flange Options



For its displacement and pressure range, the WM900 family features one of the most compact envelopes available from any manufacturer. Standard international mounting flange options are outlined below. Dimensions shown outside of brackets are metric units. (See top of page 16 for dimensional chart showing "X" and "Y" dimensions.)

SAE "A" 2-BOLT ORDER CODE 03

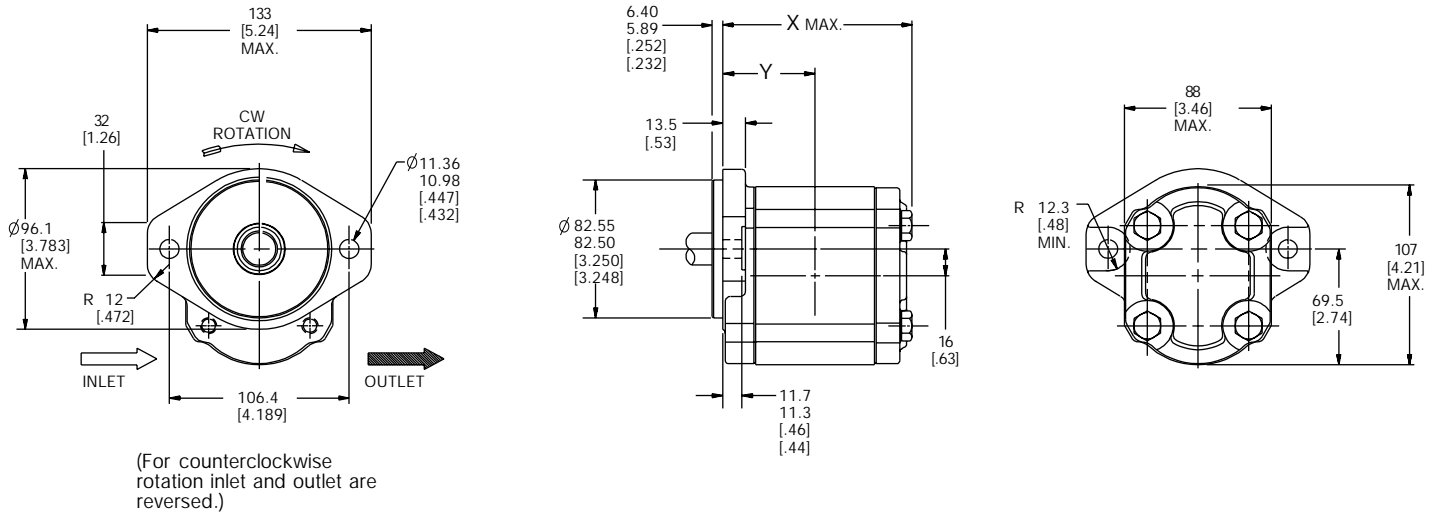

SAE "B" 2-BOLT ORDER CODE 05

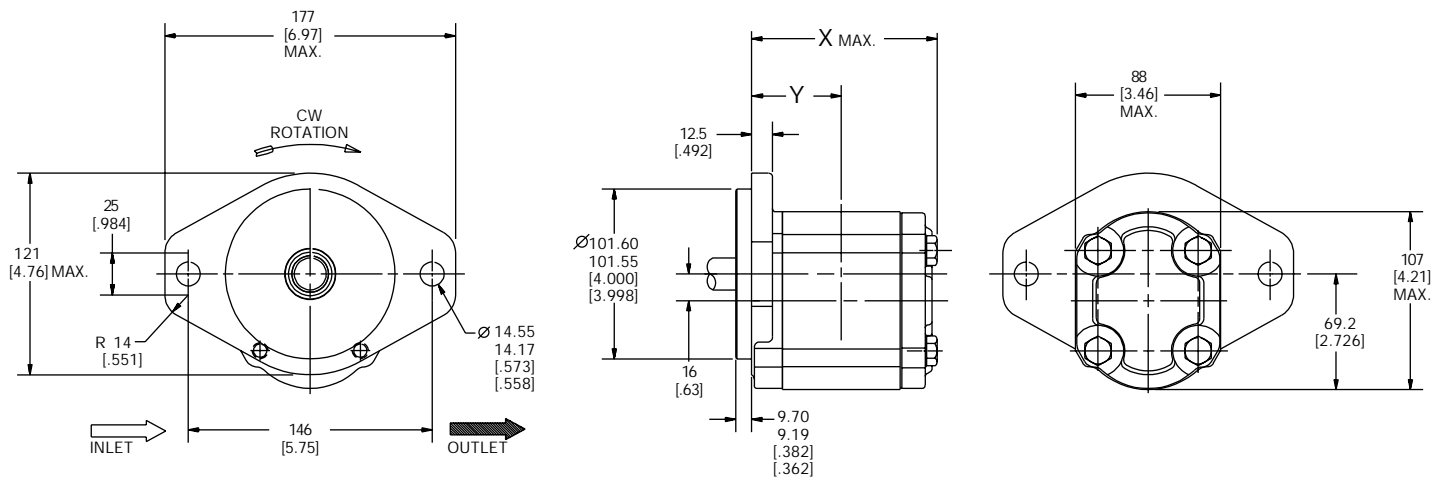

THROUGH BOLT (50.0 mm Pilot) ORDER CODES 10 & 11 *

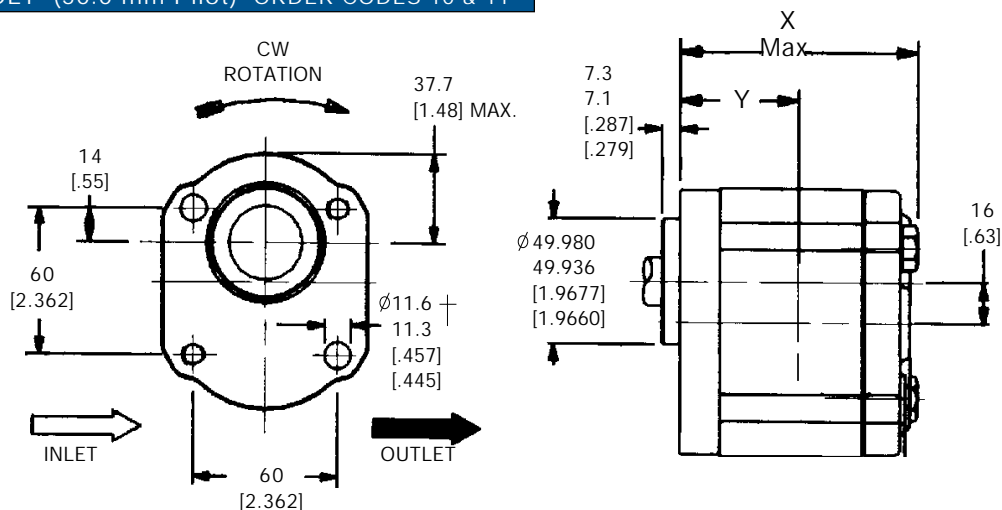

* Cannot be used with Shaft Order Code QB.
 † Use M10-10.9 screws with lockwashers. Torque screws to 60 +10 Nm [528 +88 lb. in.]



WM900 Dimensions & Weights

See dimensional drawings on page 15 which accompany the dimensional chart below.

Order Code	Displacement		Dims. & Weights with Flange Options 03 & 05			Dims. & Weights with Flange Options 10 & 11		
	cm ³	in ³	X Max.	Y (To Port Centerline)	Approx. Wt./ kg. [lbs.]	X Max.	Y (To Port Centerline)	Approx. Wt. kg. [lbs.]
060	6.0	.370	92.7 [3.65]	44.0 [1.732]	3.6 [7.9]	90.2 [3.55]	41.5 [1.634]	3.2 [7.0]
080	8.0	.490	95.0 [3.74]	45.5 [1.791]	3.7 [8.1]	92.5 [3.64]	43.0 [1.693]	3.3 [7.2]
100	10.0	.610	97.9 [3.85]	47.0 [1.850]	3.78 [8.3]	95.4 [3.75]	44.5 [1.752]	3.4 [7.4]
110	11.0	.670	100.1 [3.94]	47.7 [1.866]	3.82 [8.4]	97.6 [3.84]	45.2 [1.780]	3.45 [7.6]
140	14.0	.850	103.9 [4.09]	50.0 [1.969]	4.0 [8.8]	101.4 [3.99]	47.5 [1.870]	3.6 [7.9]
160	16.0	.980	107.5 [4.23]	51.4 [2.02]	4.1 [9.0]	105.0 [4.13]	48.9 [1.925]	3.7 [8.1]
190	19.0	1.16	111.3 [4.38]	53.7 [2.114]	4.2 [9.2]	108.8 [4.28]	51.2 [2.016]	3.8 [8.3]
230	23.0	1.40	117.2 [4.61]	56.6 [2.228]	4.4 [9.6]	114.7 [4.52]	54.1 [2.130]	4.0 [8.8]
270	27.0	1.65	123.8 [4.88]	59.6 [2.346]	4.6 [10.1]	121.3 [4.78]	57.1 [2.248]	4.2 [9.2]
280	28.0	1.71	124.6 [4.9]	60.4 [2.37]	4.7 [10.3]	122.1 [4.8]	57.9 [2.27]	4.3 [9.4]

WM900 Shaft Options

See additional shaft option on page 17.

STRAIGHT SHAFT SAE "A" ORDER CODE BA

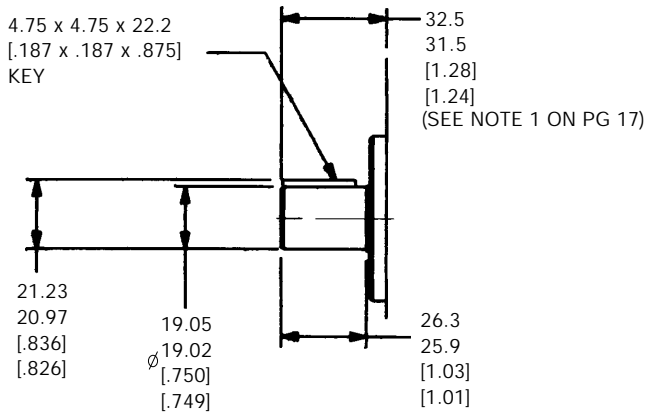

STRAIGHT SHAFT SAE "A" ORDER CODE CA

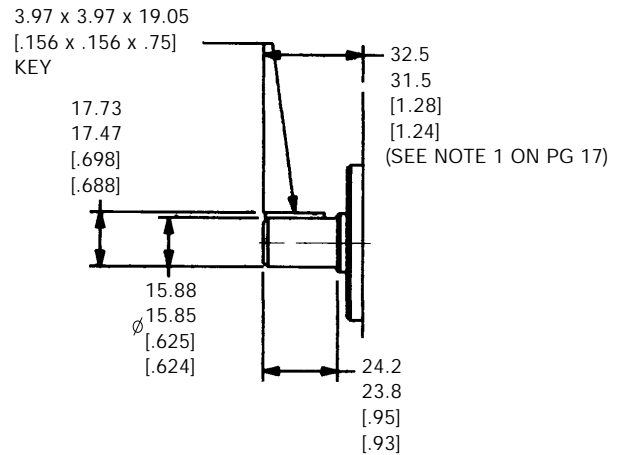

SAE "A" SPLINE ORDER CODE FA

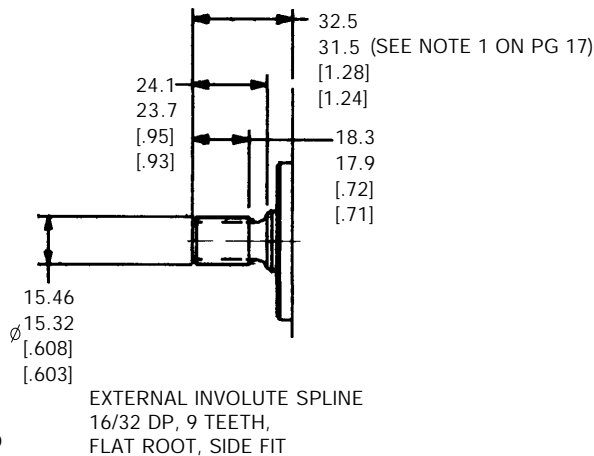

SAE "A" SPLINE ORDER CODE GA

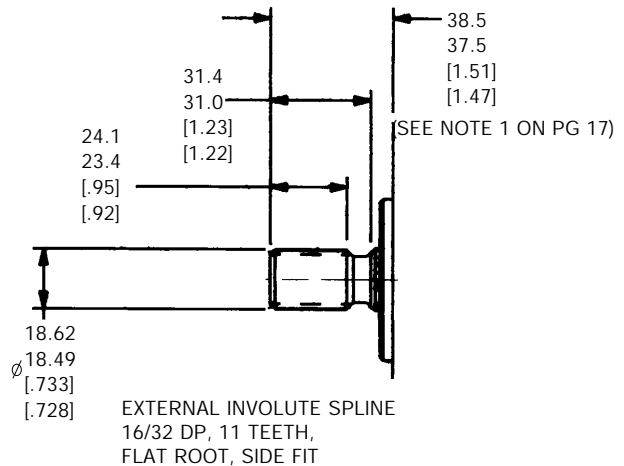

WM900 Shaft Options (cont.)



SAE "A" TAPERED ORDER CODE LA

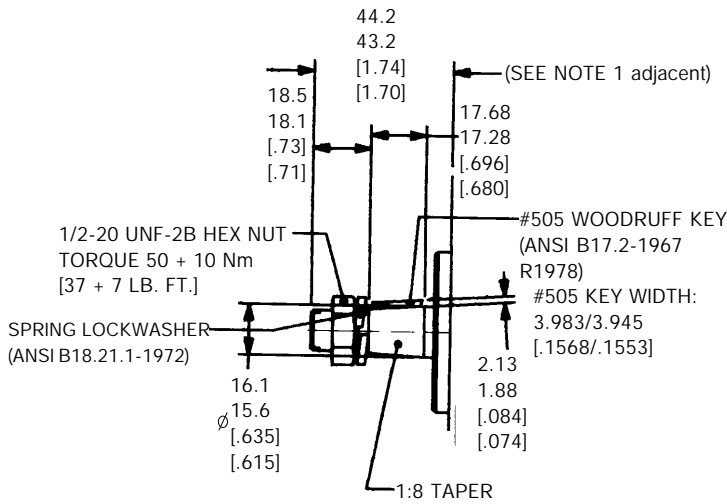

Note 1: Dimension represents shaft extension for flange Options 03 & 05.

For Through Bolt Options 10 and 11, add 2.5 mm (.098 in.) to the min. & max. shaft extension shown.

WM900 Axial/Radial Loads

MAXIMUM FLUID MOTOR AXIAL LOADS

- MAX. 700 N. (157 LBS.) AT VISCOSITY OF 10 CST (59 SSU) (BOTH DIRECTIONS)
- THE RESULTANT LOAD FROM THE AXIAL AND RADIAL FORCES MUST BE LESS THAN 1050 N. (236 LBS.).

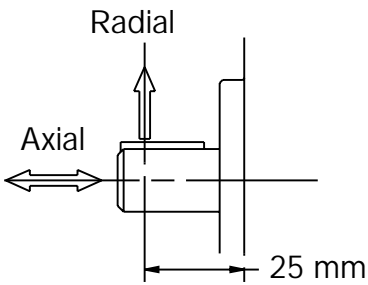

27.5 AT FLANGE OPTION 10, 11, 12, 13

MAXIMUM FLUID MOTOR RADIAL LOADS

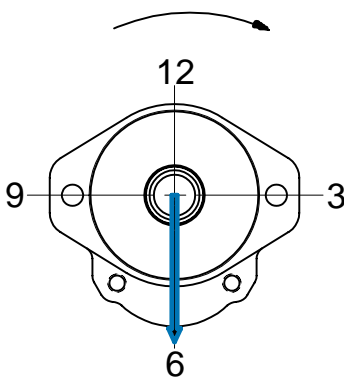

Pressure		Max. Radial Load at 6 O'Clock	
PSI	BAR	LBS	N
0-2300	0-159	240	1068
2301-2700	160-186	110	489

For all other angles and pressures, consult factory.

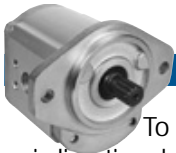

WM900 Shaft Seal Capabilities

To insure that the capabilities of the shaft seal are not exceeded, use the chart below. Outlet pressure on a uni-directional motor or case drain pressure on a bi-rotational motor must not exceed seal pressure ratings.

Description	Max. Pressure PSI (Bar)	Temp. Range °F (°C)
Standard Buna	44 (3)	-31 to 248 (-35 to 120)
Standard Viton	44 (3)	-40 to 400 (-40 to 204)
High Pressure Viton	160 (11) Cont. / 275 (19) Int.	-31 to 266 (-35 to 130)

WM900 Performance Curves @ 100 SSU

WM900, Input Flow Vs. RPM at Max. P1 Pressure with 100SSU Fluid

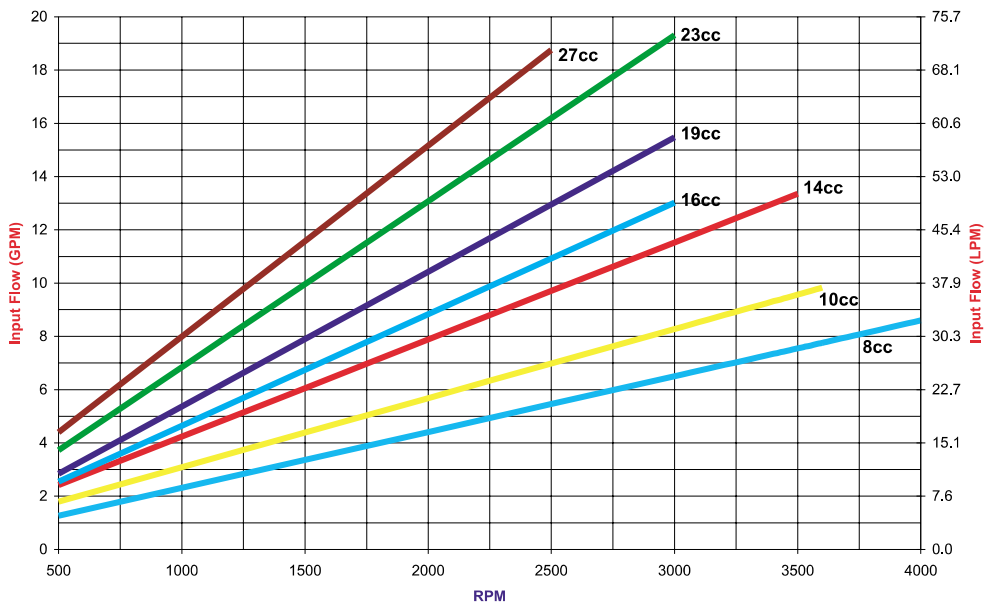

WM900 Inlet Pressure Vs. Torque at Max. RPM with 100SSU Fluid

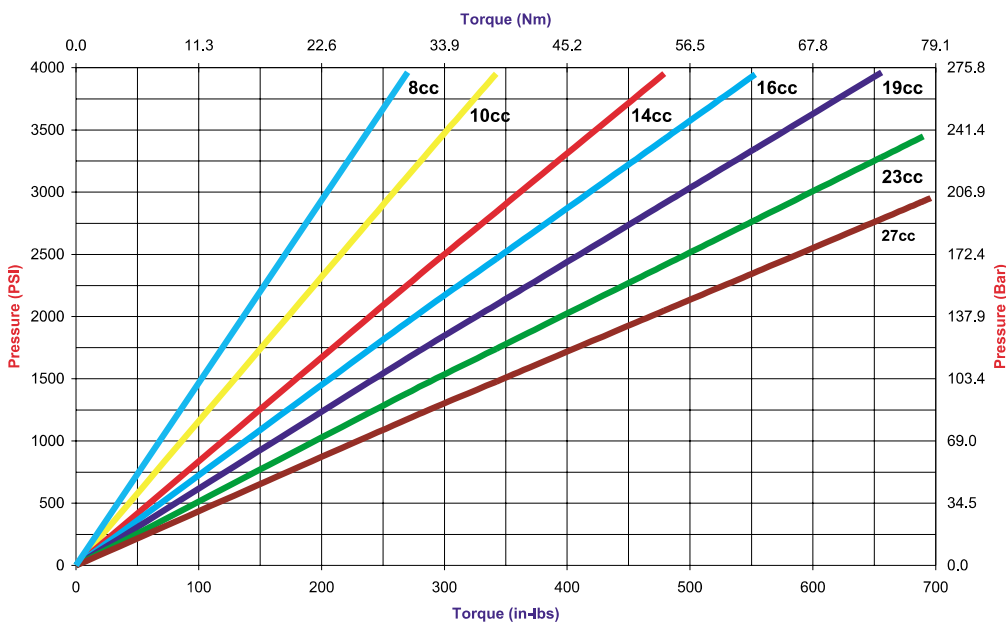

WM900 Case Drain



WM900 Case Drain Leakage vs. Pressure @ Max. RPM with 100 SSU Fluid for Displacements 8-27 cc

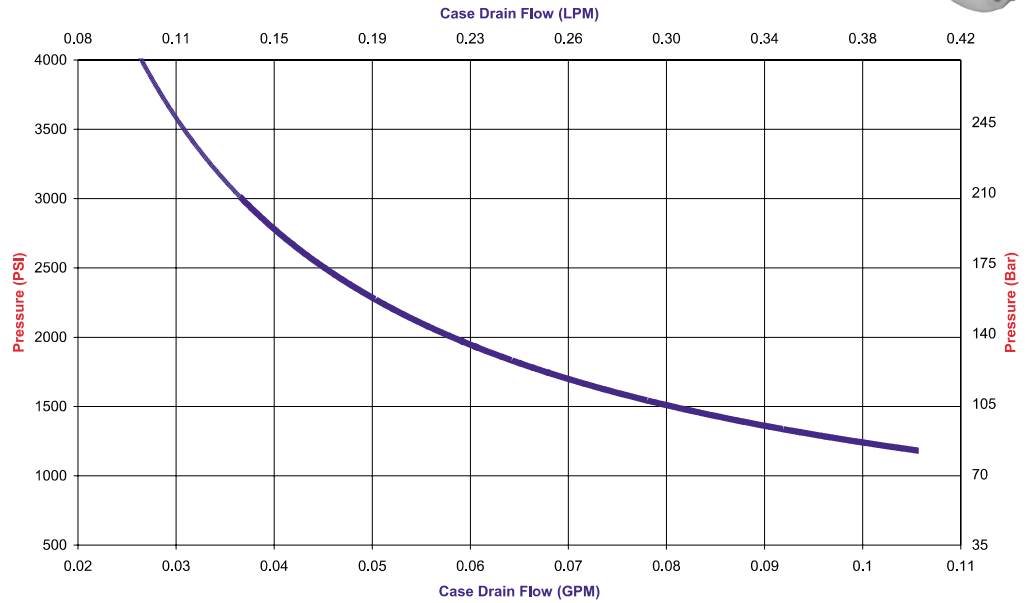

Installation Information

FLUIDS - Most premium grade petroleum base fluids can be used with WM900 Motors. Optimum operating viscosity is 16-40 cSt (80 -185 SSU) at maximum rated speed. Minimum operating viscosity is 10 cSt (59 SSU). Maximum operating viscosity is 750 cSt (3409 SSU). Maximum cold start viscosity is 2000 cSt (9091 SSU). Contact Haldex for additional information regarding the W900 performance using other fluids.

OPERATING TEMPERATURES - Fluid temperature range (Mineral Oil):

Max. 93°C (200°F) continuous; and
Max. 105°C (221°F) intermittent.

FILTRATION - Proper filtration is critical to the trouble free operating of any hydraulic system. For optimum motor life at maximum pressure ISO 4406/1986 (Code 18/14) is recommended. A 10-micron filter sized to accommodate full system return flow is recommended for most operating environments.

WM900 Valve Options

The schematic drawings shown below illustrate standard valve options offered on the WM900 hydraulic motors.

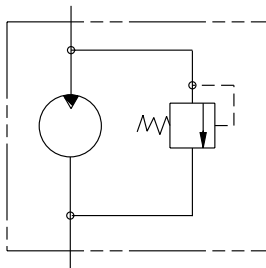

FA
Inlet Relief
Valve

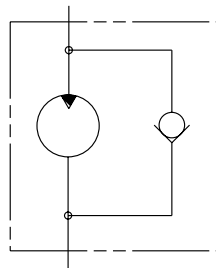

GF
Overrunning
Check Valve

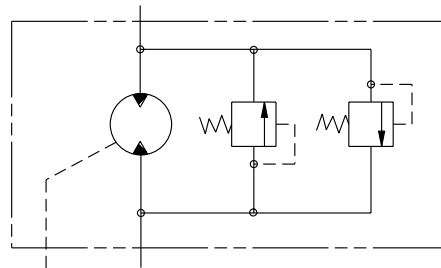

FD
Cross Over
Relief Valves
w/Case Drain

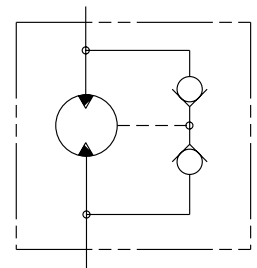

NOTE:
Check Valves
are included
when Option "C"
in Section 4 on
page 21 is selected.

OPTIONS	DESCRIPTION
FA	Inlet Relief Valve
GF	Overrunning Check Valve
FD	Cross-Over Relief Valves w/Case Drain



WM900 Valve Option Dimensions

The drawings below depict the overall dimensions for the valve options specified on page 19.

CARTRIDGE RELIEF VALVE, CW ROTATION

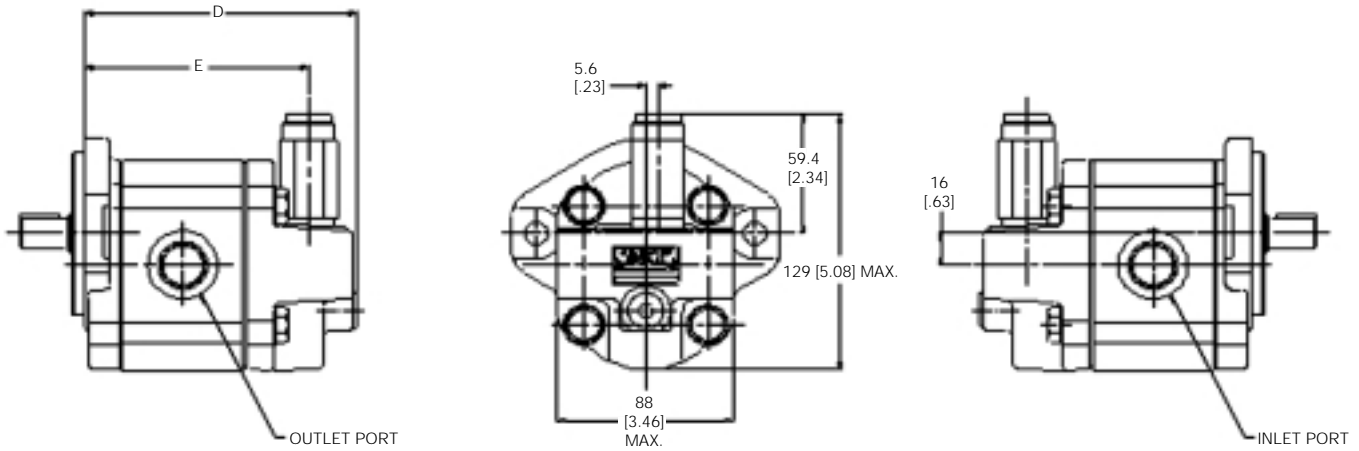

OVER-RUNNING CHECK, CW ROTATION

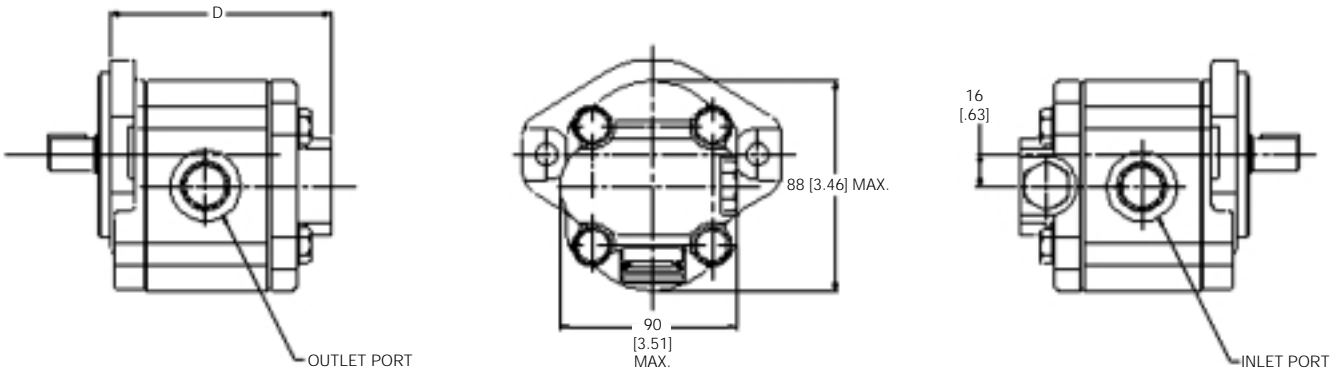

CROSS-OVER RELIEFS, CW ROTATION

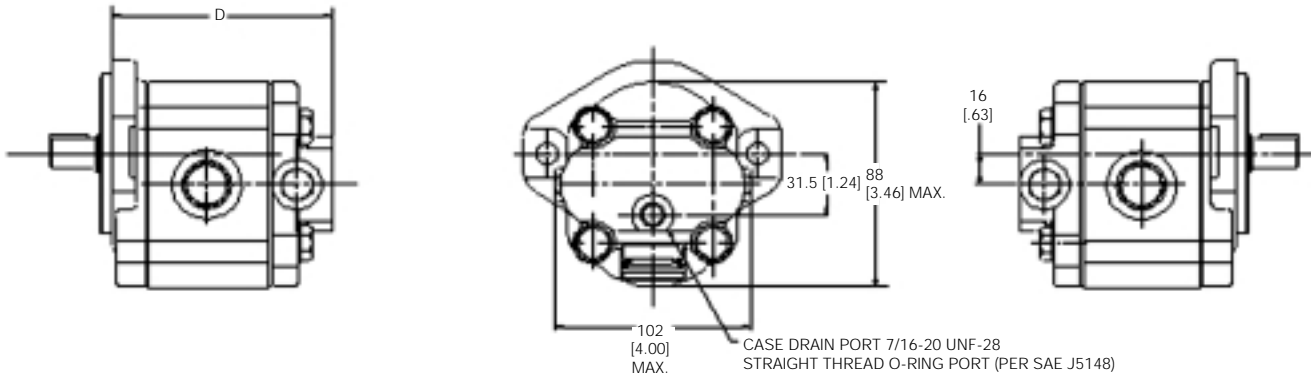

DISPLACEMENT CM ³ IN ³		D MAX.			E (TO PORT CENTERLINE)	
		FOR OVERRUNNING CHECK & CROSS-OVER RELIEF VALVES ABOVE		FOR CARTRIDGE RELIEF VALVE ABOVE	FLANGE OPTION 3 & 5	FLANGE OPTIONS 10 & 11
		FLANGES 3 & 5	FLANGES 10 & 11			
6.0	.37	125.5 [4.94]	123.0 [4.84]	102.7 [4.04]	101.8 [4.01]	99.3 [3.91]
8.0	.49	128.5 [5.06]	126.2 [4.96]	105.0 [4.13]	104.8 [4.12]	102.3 [4.03]
10.0	.61	131.4 [5.17]	128.9 [5.07]	107.9 [4.24]	107.7 [4.24]	105.2 [4.14]
11.0	.67	132.9 [5.23]	130.4 [5.13]	110.1 [4.33]	109.2 [4.30]	106.7 [4.20]
14.0	.85	137.4 [5.41]	134.9 [5.31]	113.9 [4.48]	113.7 [4.47]	111.2 [4.38]
16.0	.98	140.3 [5.52]	137.8 [5.43]	117.5 [4.62]	116.6 [4.59]	114.1 [4.49]
19.0	1.16	144.8 [5.70]	142.3 [5.60]	121.3 [4.77]	121.1 [4.67]	118.6 [4.67]
23.0	1.40	150.7 [5.93]	148.2 [5.83]	127.2 [5.00]	127.0 [5.00]	124.5 [4.90]
27.0	1.65	156.6 [6.17]	154.1 [6.07]	133.8 [5.27]	132.9 [5.23]	130.4 [5.13]
28.0	1.71	158.1 [6.22]	155.6 [6.13]	134.6 [5.29]	134.4 [5.29]	131.9 [5.19]

WM900 Hydraulic Motor Order Code

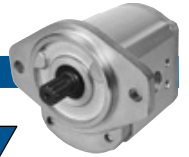

Each WM900 Series Motor option has been assigned an order code which is listed in the tables below. Configure the desired options as shown in the example model code to the right.

STANDARD MOTOR									
	1	2	3	4	5	6	7	8	9
	DESIGN CODE	SEAL MATERIAL	DISPLACEMENT	ROTATION	FLANGE	SHAFT	PORT	VALVE OPTION	RELIEF VALVE SETTINGS
EXAMPLE	WM09A1	B	060	R	02	BA	101	FA	R35
Your Options	WM09A1								

2. **SEAL MATERIAL**

B	Buna
V	Viton
C	Combination of Both

3. **DISPLACEMENT**

Order Code	cm. ³	in. ³
060	6	.366
080	8	.488
100	10	.610
110	11	.671
140	14	.854
160	16	.976
190	19	1.159
230	23	1.403
270	27	1.647
280	28	1.709

4. **ROTATION**

B	Birotational (Case Drain)
C	Birotational (Check Valves)
R	Clockwise (No Case Drain)
E	Clockwise (With Case Drain)
L	Counter Clockwise (No Case Drain)
W	Counter Clockwise (With Case Drain)

5. **MOUNTING FLANGES**

03	SAE "A" 2-Bolt
05	SAE "B" 2-Bolt
10/11	Through Bolt (50.0 mm Pilot) (Non-Tang) +

6. **DRIVE SHAFTS**

BA	SAE "A" Straight Shaft 3/4" Dia.
CA	SAE Straight Shaft 5/8" dia.
FA	SAE "A" Spline (9 Tooth)
GA	SAE "A" Spline (11 Tooth)
LA	SAE "A" Tapered (1:8)

7. **STANDARD PORTING**

DISP. ORDER CODE	SIDE PORT CODE	REAR PORT CODE	DESCRIPTION
060	101	501	SAE Straight Thread (7/8-14,3/4-16)
080-160	102	502	SAE Straight Thread (1-1/16-12,7/8-14)
190-280	103	503	SAE Straight Thread (1-5/16-12,1-1/16-12)
060-190	121	521	BSPP Straight Thread (G3/4,G1/2)
230-280	122	522	BSPP Straight Thread (G1,G3/4)
160-190	140	N/A	SAE Split Flange (3/4,1/2)
230-280	141	N/A	SAE Split Flange (1.0,3/4)
160-190	145	N/A	Metric Split Flange (19,23)
230-280	146	N/A	Metric Split Flange (25,19)
060-190	150	N/A	European 4-Bolt Flange (20,15)
230-280	151	N/A	European 4-Bolt Flange (26,18)

Note: Above are standard offerings. For other porting options, please contact factory. Rear inlet port is not available with any valve option. Side inlet must be used on all valve options.

8. **VALVE OPTIONS**

FA	Inlet Relief Valve
GF	Overrunning Check Valve
FD	Cross-over Relief Valves w/Case Drain
N	Not Applicable

9. **RELIEF VALVE SETTINGS**

R**	
**	Relief pressure divided by 100. Available in 100 PSI increments to 4000 PSI. Example: R35 = 3500 PSI
NN	Not Applicable

Note: Relief valve setting is defined at .25 GPM full bypass.

All motors require a minimum 25-piece order with the exception of those options designated with "+" (100-piece minimum). A selected number of distributor stock motors are available with no minimum order quantity.

The right to modification for technical improvements is reserved. Printed in USA © 2001.



WM1500 FLANGE OPTIONS

For its displacement and pressure range, the WM1500 family features one of the most compact envelopes available from any manufacturer. Standard international mounting flange options are outlined below. Dimensions shown outside of brackets are metric units. See page 23 for dimensional chart showing "X" and "Y" dimensions.

SAE "A" 2-BOLT ORDER CODE 04

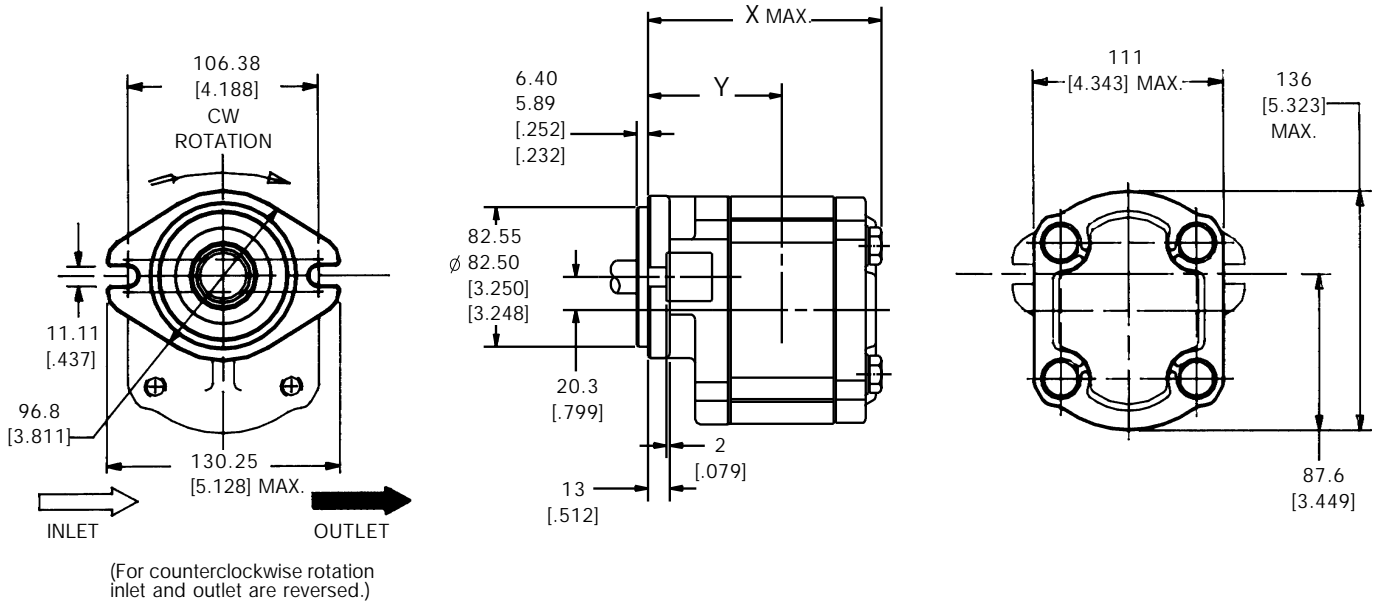

SAE "B" 2-BOLT ORDER CODE 05

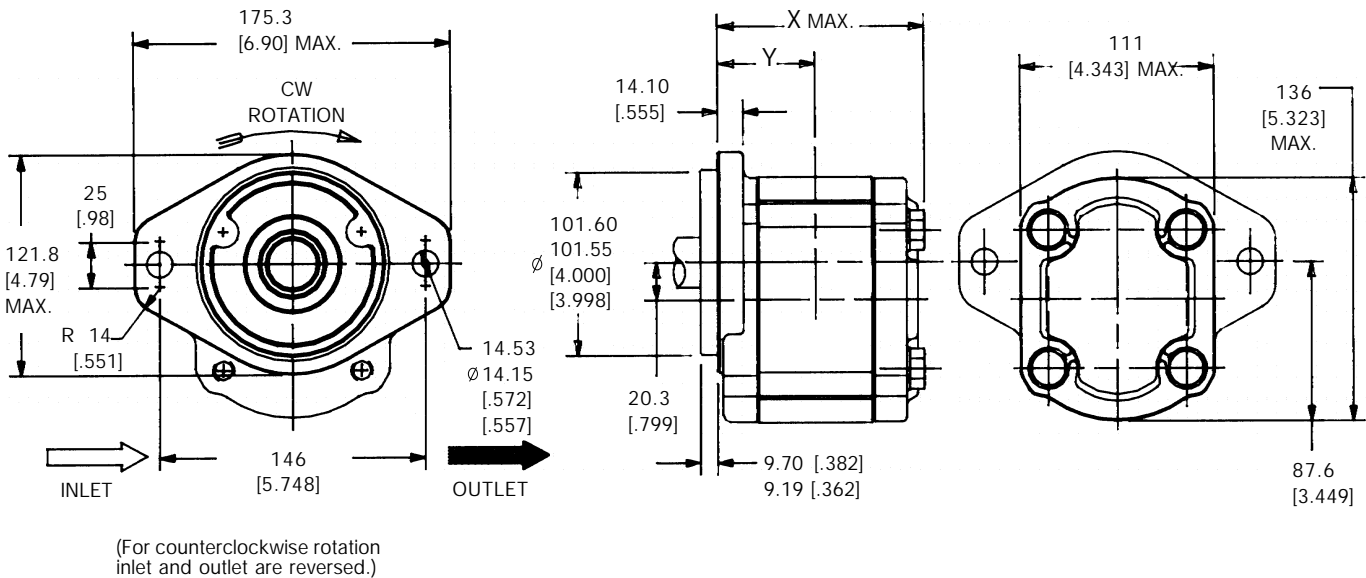

WM1500 Dimensions & Weights



* NOTE: For port code options 05 & 06, subtract 2 mm from the port centerline dimension on the 19 cc displacement only.

** NOTE: For port code options 05 & 06, subtract 2 mm from the port centerline dimension on the 28 cc displacement only.

(See dimensional drawings on page 22.)

Order Code	Displacement		Dims. & Weights with Flange Option 04			Dims. & Weights with Flange Options 05		
	CM ³	IN ³	X Max.	Y (To Port Centerline)	Approx. Wt. kg. [lbs.]	X Max.	Y (To Port Centerline)	APPROX. Wt. kg. [lbs.]
190	19.0	1.159	152.0 [5.98]	* 89.3 [3.52]	8.44 [18.62]	124.5 [4.90]	* 63.3 [2.49]	8.04 [17.73]
230	23.0	1.403	156.2 [6.15]	91.4 [3.60]	8.64 [19.05]	128.7 [5.07]	65.4 [2.57]	8.23 [18.14]
250	25.0	1.525	158.4 [6.24]	92.5 [3.64]	8.74 [19.27]	130.9 [5.15]	66.6 [2.62]	8.32 [18.35]
280	28.0	1.708	161.4 [6.35]	94.0 [3.70]	8.88 [19.59]	133.9 [5.27]	68.0 [2.68]	8.46 [18.66]
330	33.0	2.013	166.6 [6.56]	** 96.6 [3.80]	9.12 [20.12]	139.1 [5.48]	** 70.6 [2.78]	8.69 [19.16]
380	38.0	2.318	171.8 [6.76]	99.2 [3.91]	9.38 [20.66]	144.3 [5.68]	73.2 [2.88]	8.93 [19.68]
440	44.0	2.684	178.0 [7.01]	102.3 [4.83]	9.67 [21.32]	150.5 [5.93]	76.3 [3.00]	9.21 [20.30]
500	50.0	3.050	184.2 [7.25]	105.4 [4.15]	9.96 [21.97]	156.7 [6.17]	79.4 [3.13]	9.49 [20.92]

WM1500 Shaft Options

See additional shaft options on page 24.

STRAIGHT SHAFT SAE "A" ORDER CODE BA

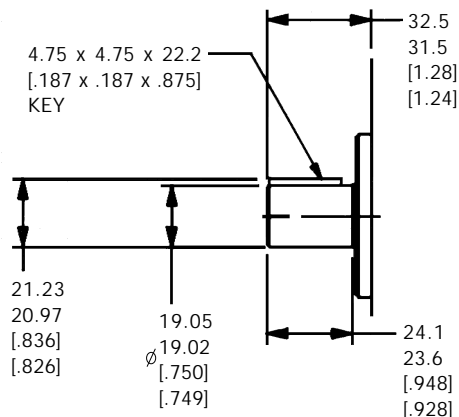

STRAIGHT SHAFT SAE "B" ORDER CODE DA

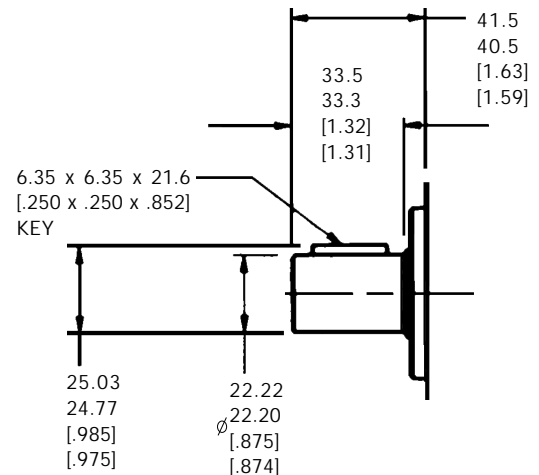



WM1500 Shaft Options (cont.)

SAE "A" 9T SPLINE ORDER CODE FA

SAE "A" 11T SPLINE ORDER CODE GA

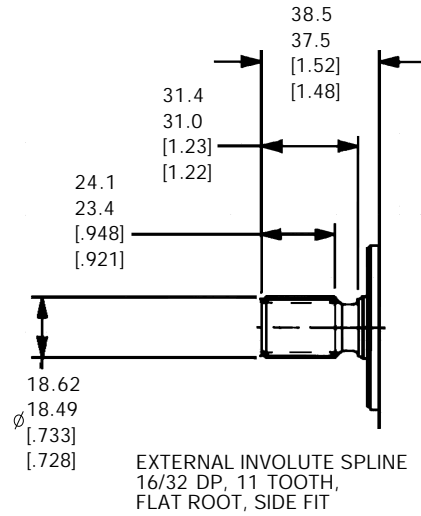
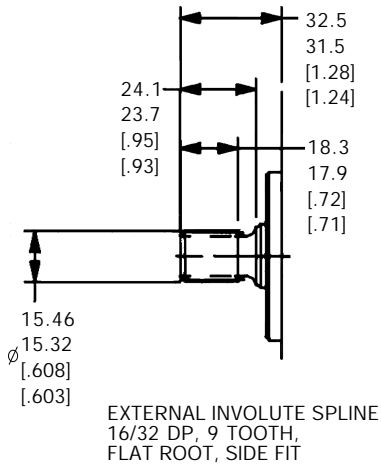

SAE "B" 13T SPLINE ORDER CODE KA

SAE "B" TAPERED (1:8) ORDER CODE UB

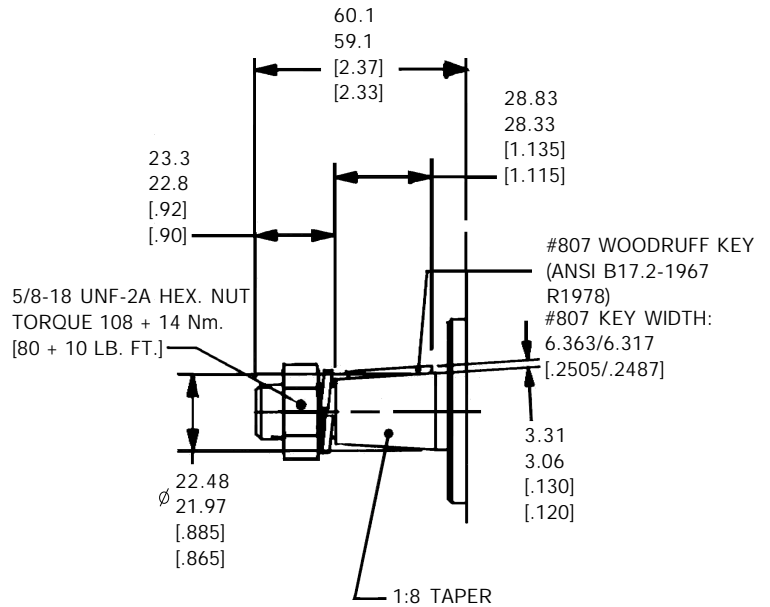
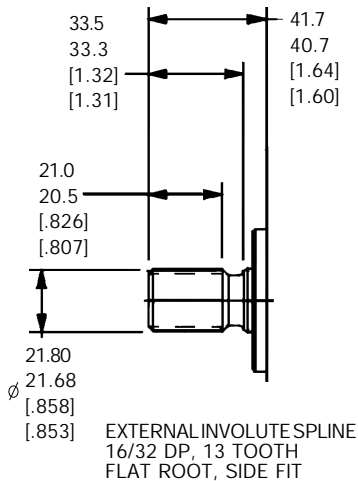



MAXIMUM FLUID MOTOR AXIAL LOADS

- MAX. 1200 N. (270 LBS.) AT VISCOSITY OF 10 CST (59 SSU) (BOTH DIRECTIONS)
- THE RESULTANT LOAD FROM THE AXIAL AND RADIAL FORCES MUST BE LESS THAN 1800 N. (405 LBS.).

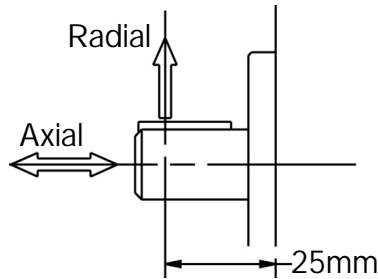

MAXIMUM FLUID MOTOR RADIAL LOADS

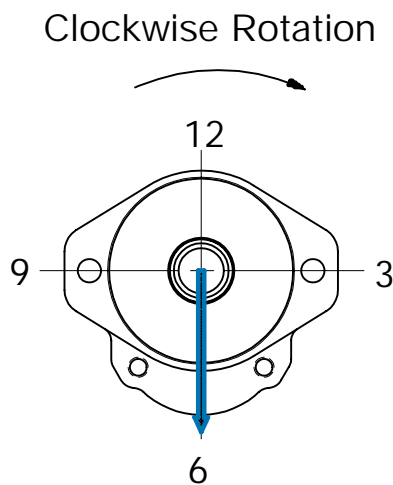

Pressure		Max. Radial Load at 6 O'Clock	
PSI	BAR	LBS	N
0-1800	0-124	340	1512
1801-2300	125-159	200	890

For all other angles and pressures, consult factory.



WM1500 Shaft Seal Capabilities

To insure that the capabilities of the shaft seal are not exceeded, use the chart below. Outlet pressure on a uni-directional motor or case drain pressure on a bi-rotational motor must not exceed seal pressure ratings.

Description	Max. Pressure PSI (Bar)	Temp. Range °F (°C)
Standard Buna	44 (3)	-31 to 248 (-35 to 120)
Standard Viton	44 (3)	-31 to 400 (-35 to 204)
High Pressure Viton	150 (10.5) cont. / 250 (17) int.	-31 to 320 (-35 to 160)

WM1500 Performance Curves @ 100 SSU

WM1500, Flow vs. RPM at Max. P1 Pressure with 100SSU Fluid

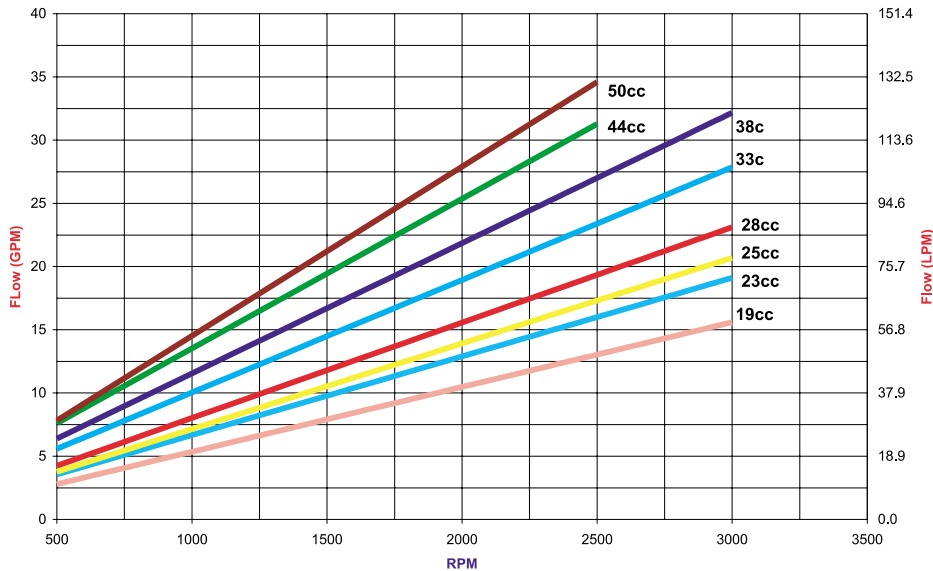

WM1500, Inlet Pressure vs. Output Torque at Max. RPM with 100SSU Fluid

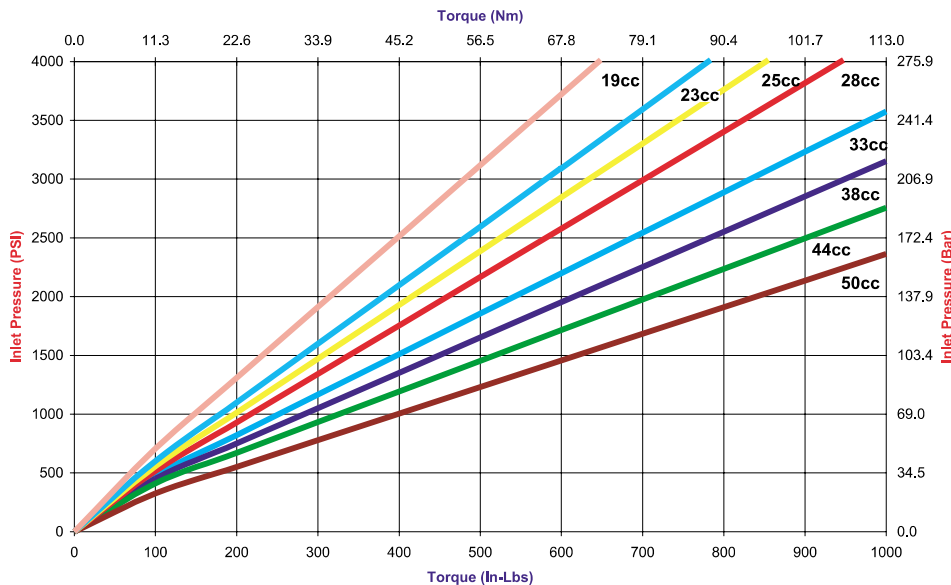

WM1500 Case Drain



WM1500 Case Drain Leakage vs. Inlet Pressure at Max. RPM with 100 SSU Fluid

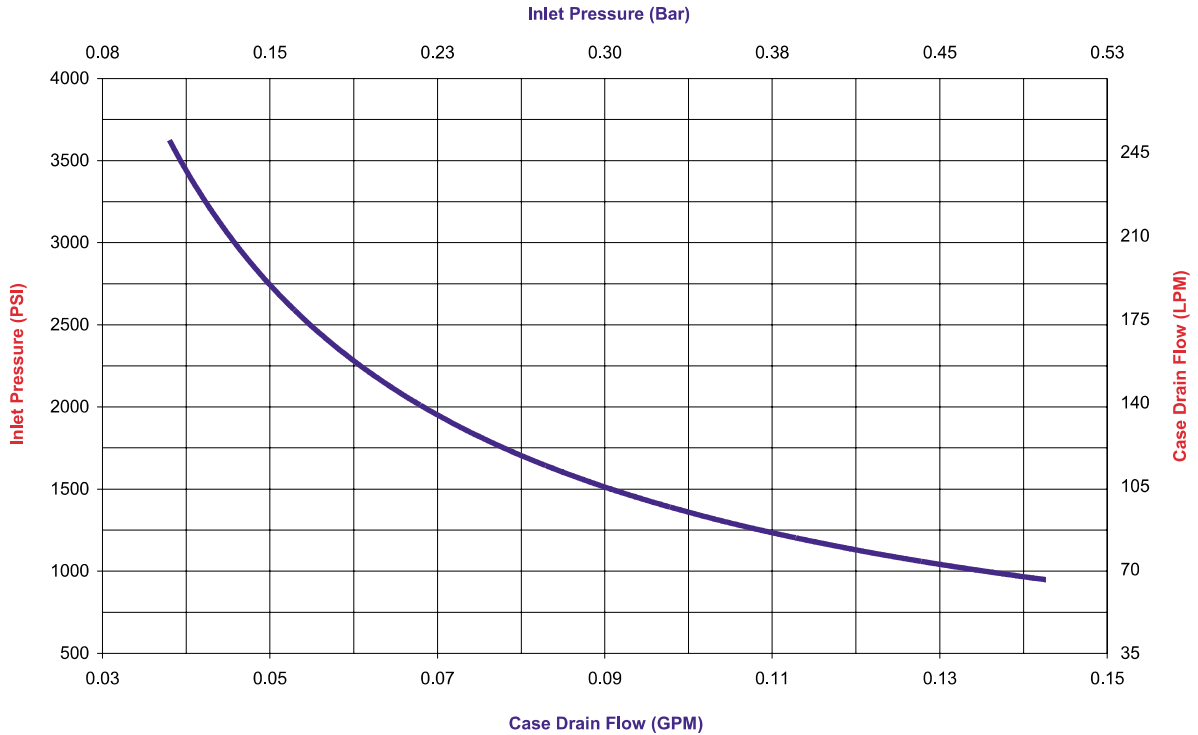

Installation Information

FLUIDS - Most premium grade petroleum base fluids can be used with WM1500 Motors. Optimum operating viscosity is 16-40 cSt (80 - 185 SSU) at maximum rated speed. Minimum operating viscosity is 10 cSt (59 SSU). Maximum operating viscosity is 750 cSt (3409 SSU). Maximum cold start viscosity is 2000

cSt (9091 SSU). Contact Haldex for additional information regarding the W1500 performance using other fluids.

OPERATING TEMPERATURES - Fluid temperature range (Mineral Oil): Max. 93°C (200°F) continuous and Max. 105°C (221°F) intermittent.

FILTRATION - Proper filtration is critical to the trouble free operation of any hydraulic system. For optimum motor life at maximum pressure ISO 4406/1986 (Code 18/14) is recommended. A 10-micron filter sized to accommodate full system return flow is recommended for most operating environments.



WM1500 Valve Options

The schematic drawings shown below illustrate standard valve options offered on the WM1500 hydraulic motors.

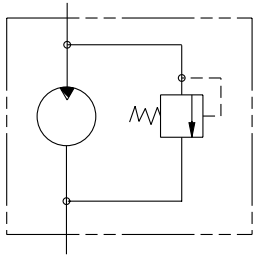

FA
Inlet Relief
Valve

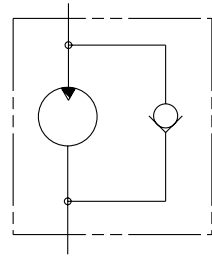

GF
Overrunning
Check Valve

OPTIONS	
FA	Inlet Relief Valve
GF	Overrunning Check Valve

WM1500 Valve Option Dimensions

The drawings below depict the overall dimensions for the valve options specified on page 27.

CARTRIDGE RELIEF VALVE, CW ROTATION

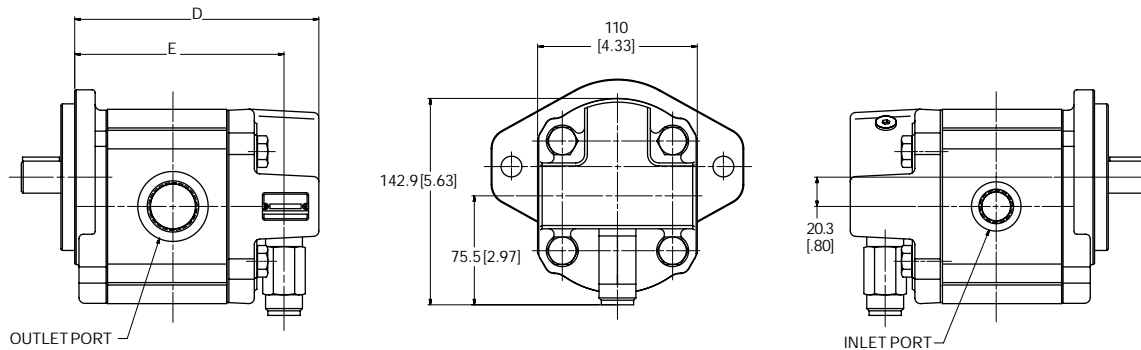

OVER-RUNNING CHECK, CW ROTATION

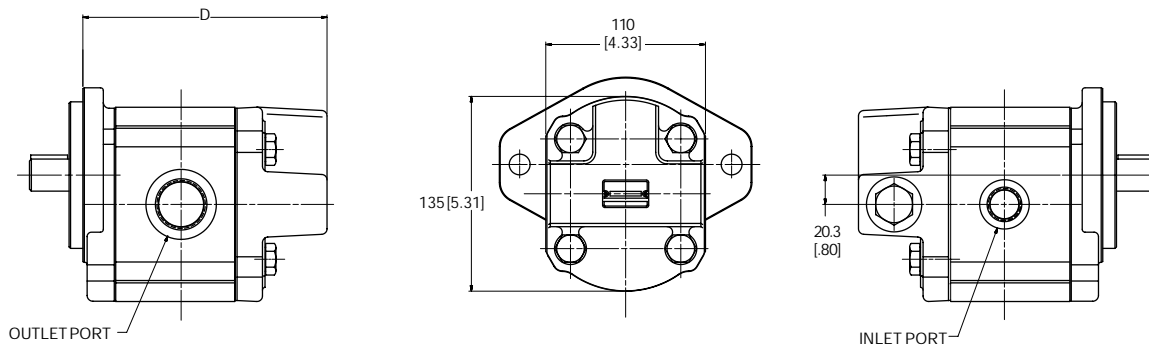

DISPLACEMENT CM ³ IN ³	D MAX.		E (TO PORT CENTERLINE)	
	FLANGE OPTION 04	FLANGE OPTIONS 05	FLANGE OPTION 04	FLANGE OPTIONS 05
19.0 1.159	186.6 [7.35]	160.0 [6.30]	151.3 [5.96]	124.9 [4.92]
23.0 1.403	190.8 [7.51]	164.2 [6.47]	155.5 [6.12]	129.1 [5.08]
25.0 1.525	193.0 [7.60]	166.4 [6.55]	157.7 [6.21]	131.3 [5.17]
28.0 1.708	196.0 [7.72]	169.4 [6.67]	160.7 [6.33]	134.3 [5.29]
33.0 2.013	201.2 [7.92]	174.6 [6.88]	165.9 [6.53]	139.5 [5.49]
38.0 2.318	206.4 [8.13]	179.8 [7.08]	171.1 [6.74]	144.7 [5.70]
44.0 2.684	212.6 [8.37]	186.0 [7.32]	177.3 [6.98]	150.9 [5.94]
50.0 3.050	218.8 [8.61]	192.2 [7.57]	183.5 [7.22]	157.1 [6.19]

WM1500 Hydraulic Motor Order Code



Each WM1500 Series Motor option has been assigned an order code which is listed in the tables below. Configure the desired options as shown in the example model code to the right.

		STANDARD MOTOR								
		1	2	3	4	5	6	7	8	9
		DESIGN CODE	SEAL MATERIAL	DISPLACEMENT	ROTATION	FLANGE	SHAFT	PORT	VALVE OPTION	RELIEF VALVE SETTING
EXAMPLE	WM15A1	B	380	R	04	BA	104	FA	R35	
Your Options	WM15A1									

2. **SEAL MATERIAL**

B	Buna
V	Viton
C	Combination of Both

3. **DISPLACEMENT**

Order Code	Cm. ³	In. ³
190	19	1.159
230	23	1.403
250	25	1.525
280	28	1.708
330	33	2.013
380	38	2.318
440	44	2.684
500	50	3.050

4. **ROTATION**

B	Berotational (Case Drain)
C	Berotational (Check Valves)
R	Clockwise (No Case Drain)
E	Clockwise (With Case Drain)
L	Counter Clockwise (No Case Drain)
W	Counter Clockwise (With Case Drain)

5. **MOUNTING FLANGES**

04	SAE "A" 2-Bolt
05	SAE "B" 2-Bolt

6. **DRIVE SHAFTS**

BA	SAE "A" Straight Shaft 3/4" Dia.
DA	SAE "B" Straight Shaft 7/8" Dia.
FA	SAE "A" Spline (9 Tooth)
GA	SAE "A" Spline (11 Tooth)
KA	SAE "B" Spline (13 Tooth)
UB	SAE "B" Tapered (1:8)

7. **STANDARD PORTING**

DISP. ORDER CODE	SIDE PORT CODE	REAR PORT CODE	DESCRIPTION
190-250	103	503	SAE Straight Thread (1-5/16-12,1-1/16-12)
280-500	104	504	SAE Straight Thread (1-5/8-12,1-5/16-12)
190-250	122	522	BSPP Straight Thread (G1,G3/4)
280-500	123	523	BSPP Straight Thread (G1-1/4,G1)
190-250	141	N/A	SAE Split Flange (1.0,3/4)
280-500	142	N/A	SAE Split Flange (1-1/4,1.0)
190-250	146	N/A	Metric Split Flange (25,19)
280-500	147	N/A	Metric Split Flange (32,25)
190-500	151	N/A	European 4-Bolt Flange (26,18)

Note: Above are standard offerings. For other porting options, please contact factory.

8. **VALVE OPTIONS**

FA	Inlet Relief Valve
GF	Overrunning Check Valve
N	Not Applicable

9. **RELIEF VALVE SETTINGS**

R**	
**	Relief pressure divided by 100. Available in 100 PSI increments to 4000 PSI. Example: R35 = 3500 PSI
NN	Not Applicable

Note: Relief valve setting is defined at .25 GPM full bypass.

All motors require a minimum 25-piece order with the exception of those options designated with "+" (100-piece minimum). A selected number of distributor stock motors are available with no minimum order quantity.

The right to modification for technical improvements is reserved. Printed in USA.



H Series Hydraulic Motors

H Series Hydraulic Motors offer excellent starting characteristics. All H Series Motors are birotational and are of cast iron construction. H motors are available with a .75" keyed shaft and NPT rear ports.

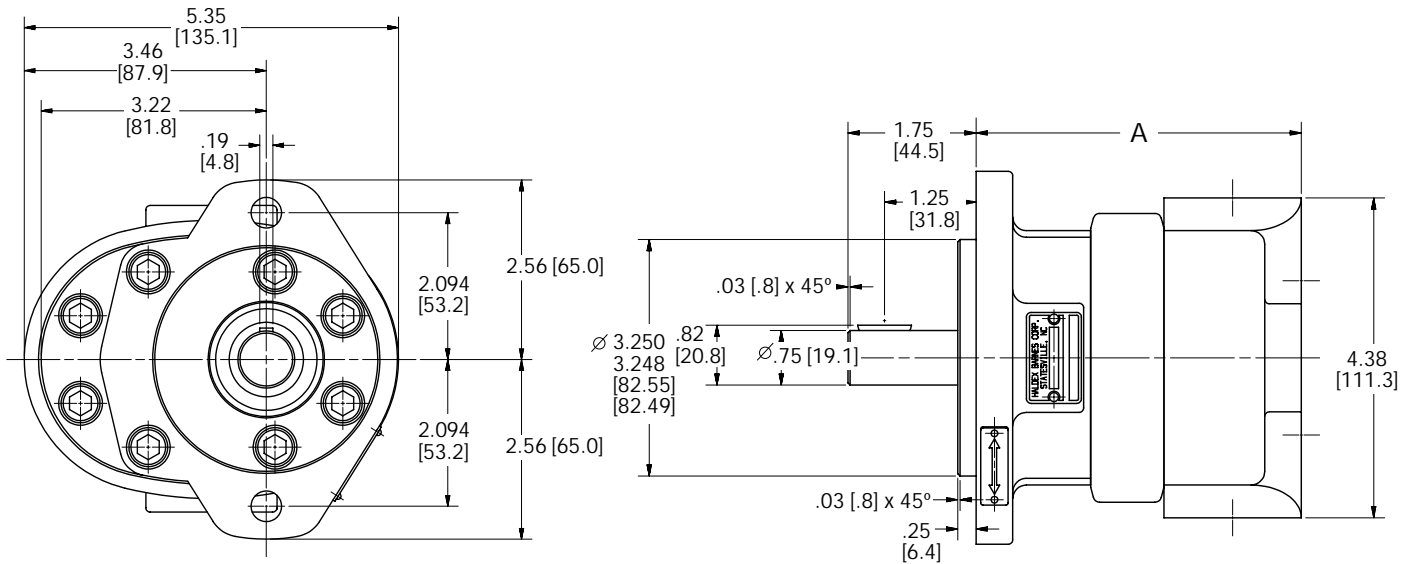

BI-ROTATIONAL

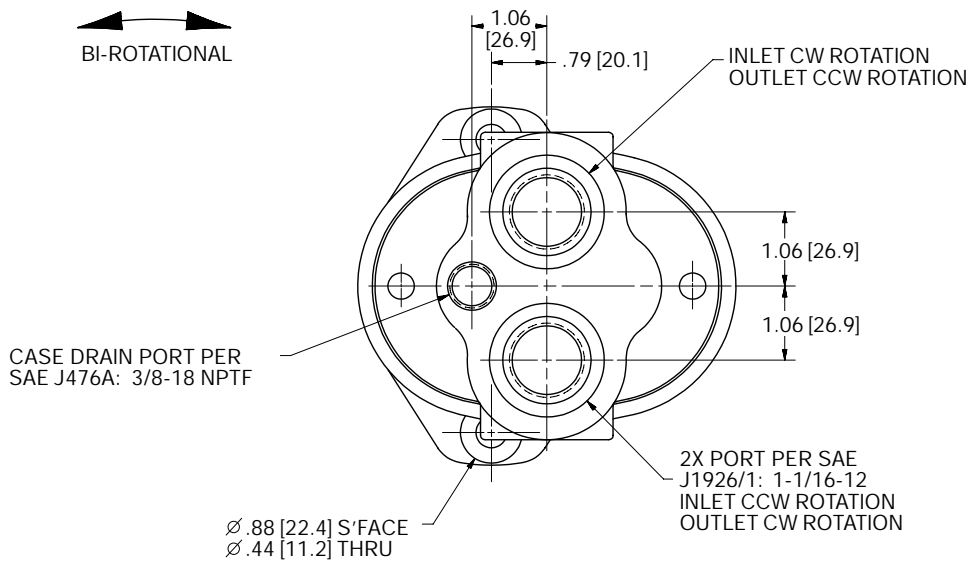

Displacement In. ³ (cc)	"A" Inch (mm)
2.40 (39)	5.44 [138.2]
2.10 (34)	5.19 [131.8]
1.80 (30)	4.94 [125.5]
1.50 (25)	4.69 [119.1]
1.20 (20)	4.44 [112.8]
.90 (15)	4.19 [106.4]
.75 (12)	4.07 [103.4]
.60 (10)	3.94 [100.1]

H Series Performance Curves @ 100 SSU



Note: All displacements are cc/rev.

H Motors Speed vs Flow at 120°F using ISO VG 32 Fluid
Nominal Pressure = 800 psig

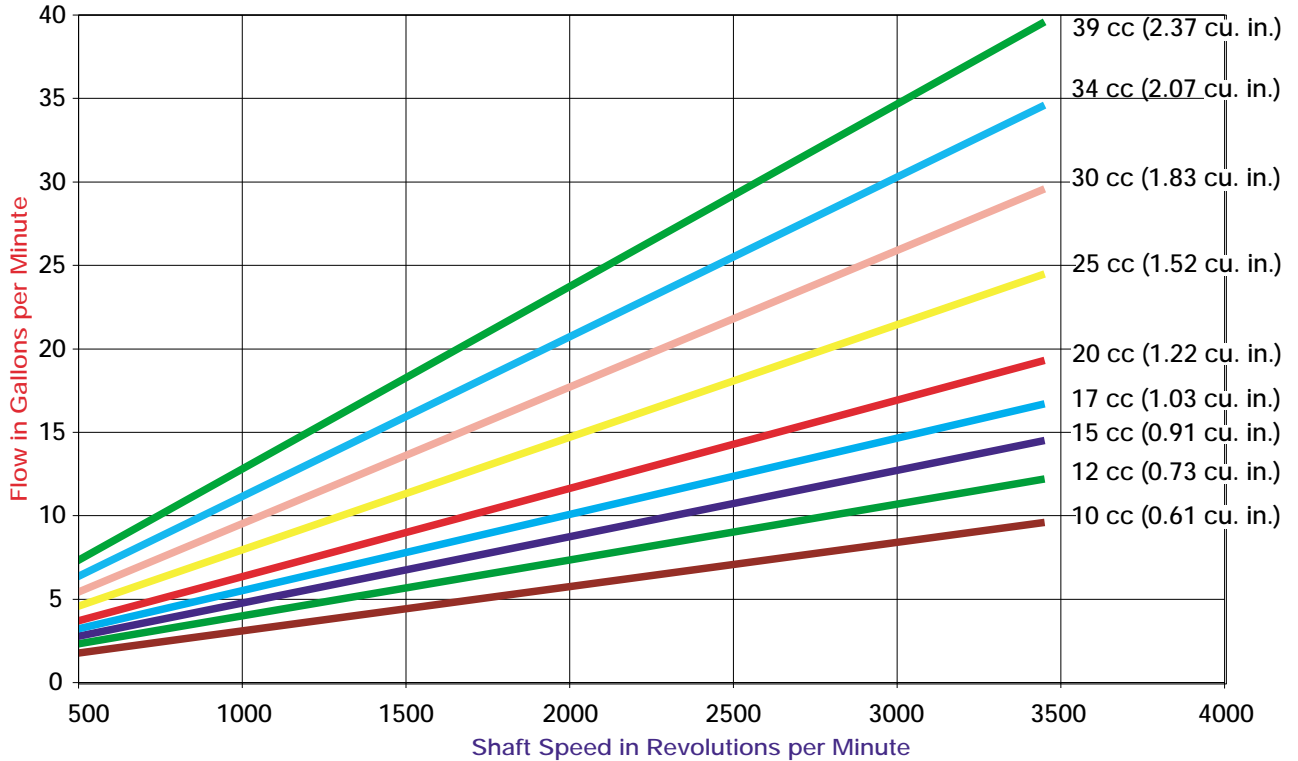

H Motor Pressure vs Torque at Maximum RPM at 120°F using ISO VG 32 Fluid

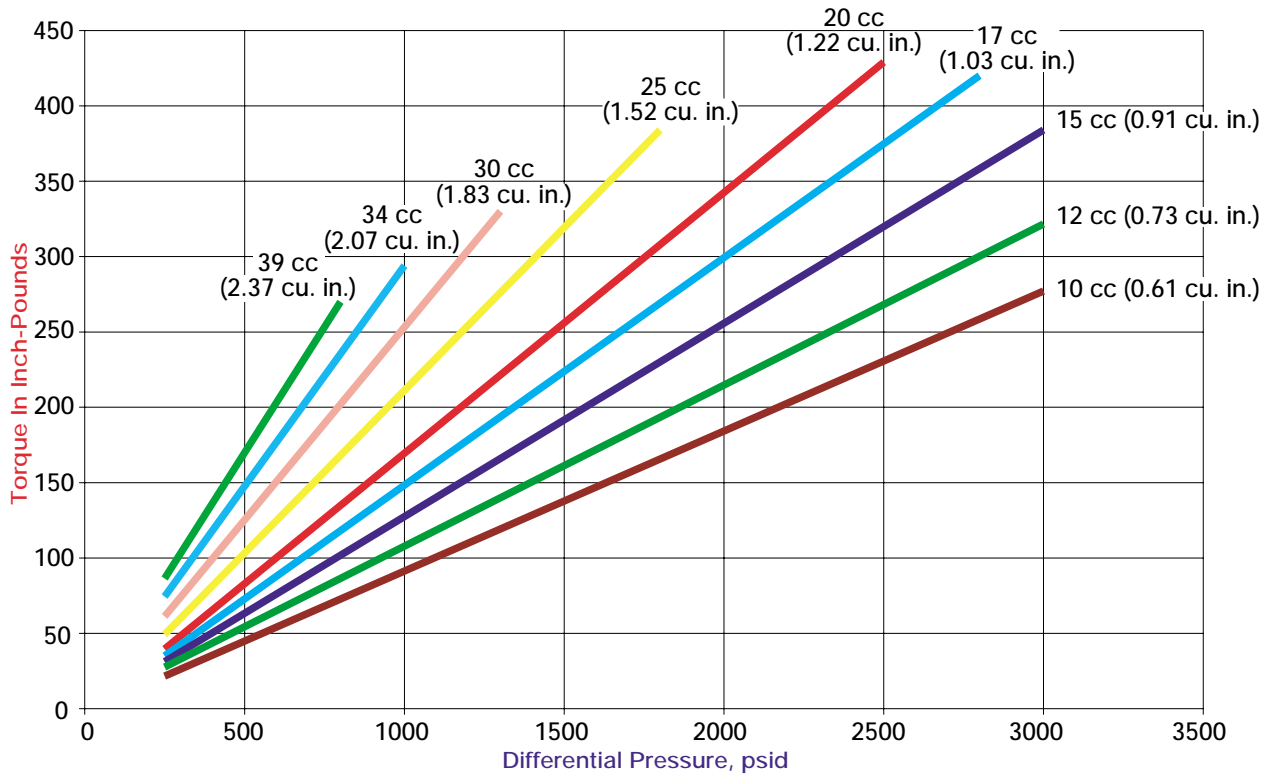



H Series Motor Starting Characteristics

Note: All displacements are cc/rev.

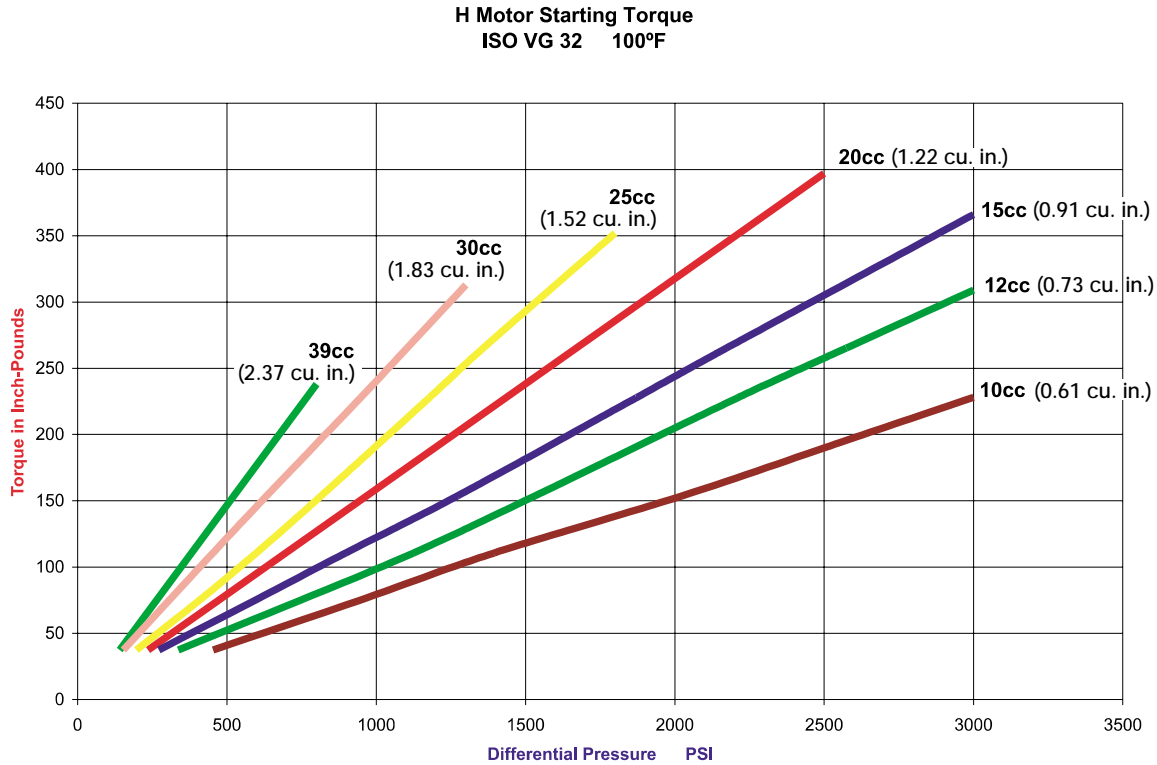

H Series Hydraulic Motor Order Code

Displacement	Item Number	Model Number
.60 in. ³ (10 cc)	1300074	P1-H-1303-CA-16-22
.75 in. ³ (12 cc)	1300075	P1-H-1303-CA-20-22
.90 in. ³ (15 cc)	1300076	P1-H-1303-CA-24-22
1.20 in. ³ (20 cc)	1300078	P1-H-1303-CA-32-22
1.50 in. ³ (25 cc)	1300079	P1-H-1303-CA-40-22
1.80 in. ³ (30 cc)	1300080	P1-H-1303-CA-48-22
2.10 in. ³ (34 cc)	1300081	P1-H-1303-CA-56-22
2.40 in. ³ (39 cc)	1300082	P1-H-1303-CA-64-22

All H Series Motors incorporate a 3/4" keyed shaft and NPT rear ports.

GM20 & GM30 UNIDIRECTIONAL HYDRAULIC MOTORS



GM20 and GM30 Series motors provide excellent high speed performance in parallel circuit applications. Available with a standard 150 PSI shaft seal (optional 500 PSI seal available), these motors feature a durable cast iron construction and excellent efficiencies. A wide variety of shaft and porting options are available.

GM20 Motor Dimensional Information

(Wet Mounting Flange Design)

Installation dimensions in inches (mm)

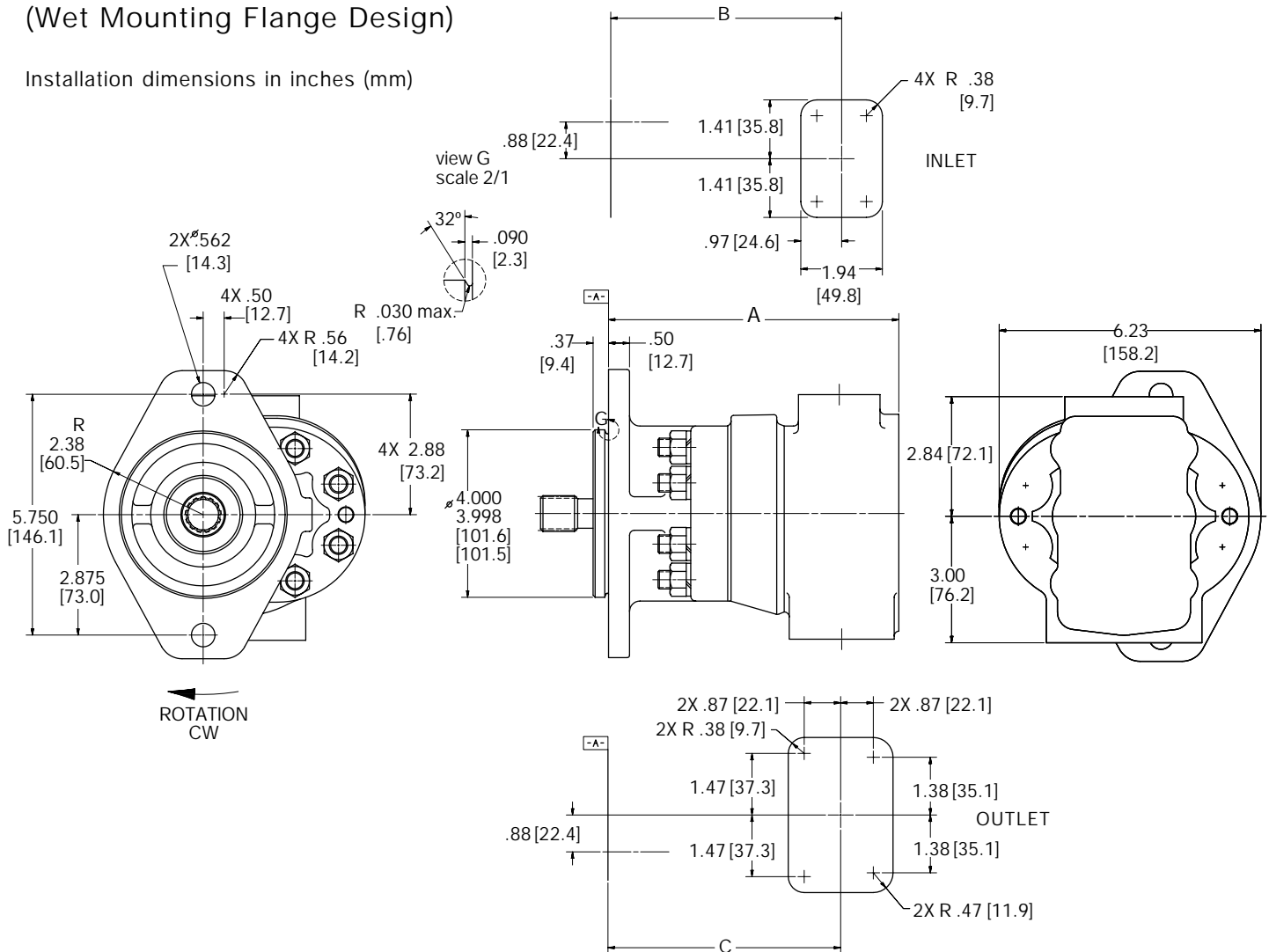

NOTE: SAE "B" 2-bolt mounting flange shown.

• Model	"A" mm (inch)	"B" mm (inch)	"C" mm (inch)
GM20W-2*7*-**61	154.7 (6.09)	117.6 (4.63)	123.2 (4.85)
GM20W-2*9*-**61	159.3 (6.27)	122.2 (4.81)	127.8 (5.03)
GM20W-2*11*-**61	163.8 (6.45)	126.8 (4.99)	132.3 (5.21)
GM20W-2*13*-**61	168.7 (6.64)	131.6 (5.18)	137.2 (5.40)
GM20W-2*15*-**61	172.7 (6.80)	135.6 (5.34)	141.2 (5.56)
GM20W-2*17*-**61	177.0 (6.97)	140.0 (5.51)	145.5 (5.73)
GM20W-2*19*-**61	182.1 (7.17)	145.0 (5.71)	150.6 (5.93)
GM20W-2*21*-**61	186.4 (7.34)	149.4 (5.88)	154.9 (6.10)
GM20W-2*24*-**61	193.3 (7.61)	156.2 (6.15)	161.8 (6.37)
GM20W-2*27*-**61	200.2 (7.88)	163.1 (6.42)	168.7 (6.64)

• For complete model description, refer to code, page 41.



GM30 Motor Dimensional Information

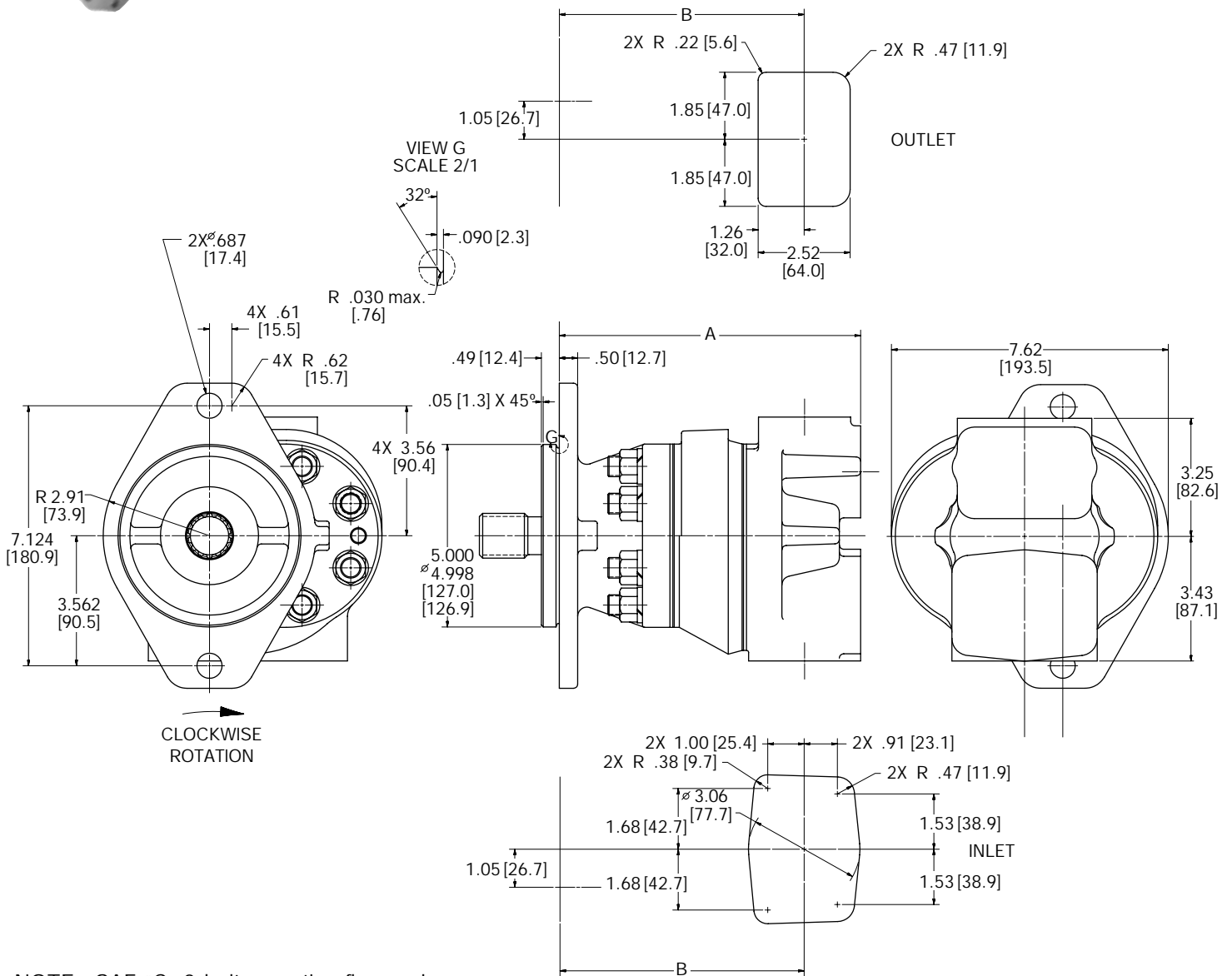

NOTE: SAE "C" 2-bolt mounting flange shown.

• Model	"A" mm (inch)	"B" mm (inch)
GM30- **18*2-****32	190.3 (7.49)	151.4 (5.96)
GM30- **21*2-****32	195.1 (7.68)	156.2 (6.15)
GM30- **25*2-****32	201.4 (7.93)	162.6 (6.40)
GM30- **28*2-****32	206.2 (8.12)	167.4 (6.59)
GM30- **30*2-****32	209.3 (8.24)	170.4 (6.71)
GM30- **32*2-****32	212.6 (8.37)	173.7 (6.84)
GM30- **35*2-****32	217.2 (8.55)	178.3 (7.02)
GM30- **40*2-****32	224.8 (8.85)	183.9 (7.32)
GM30- **45*2-****32	232.7 (9.16)	193.8 (7.63)
GM30- **50*2-****32	240.5 (9.47)	201.7 (7.94)

Mounting Flanges for GM20/GM30 Hydraulic Motors

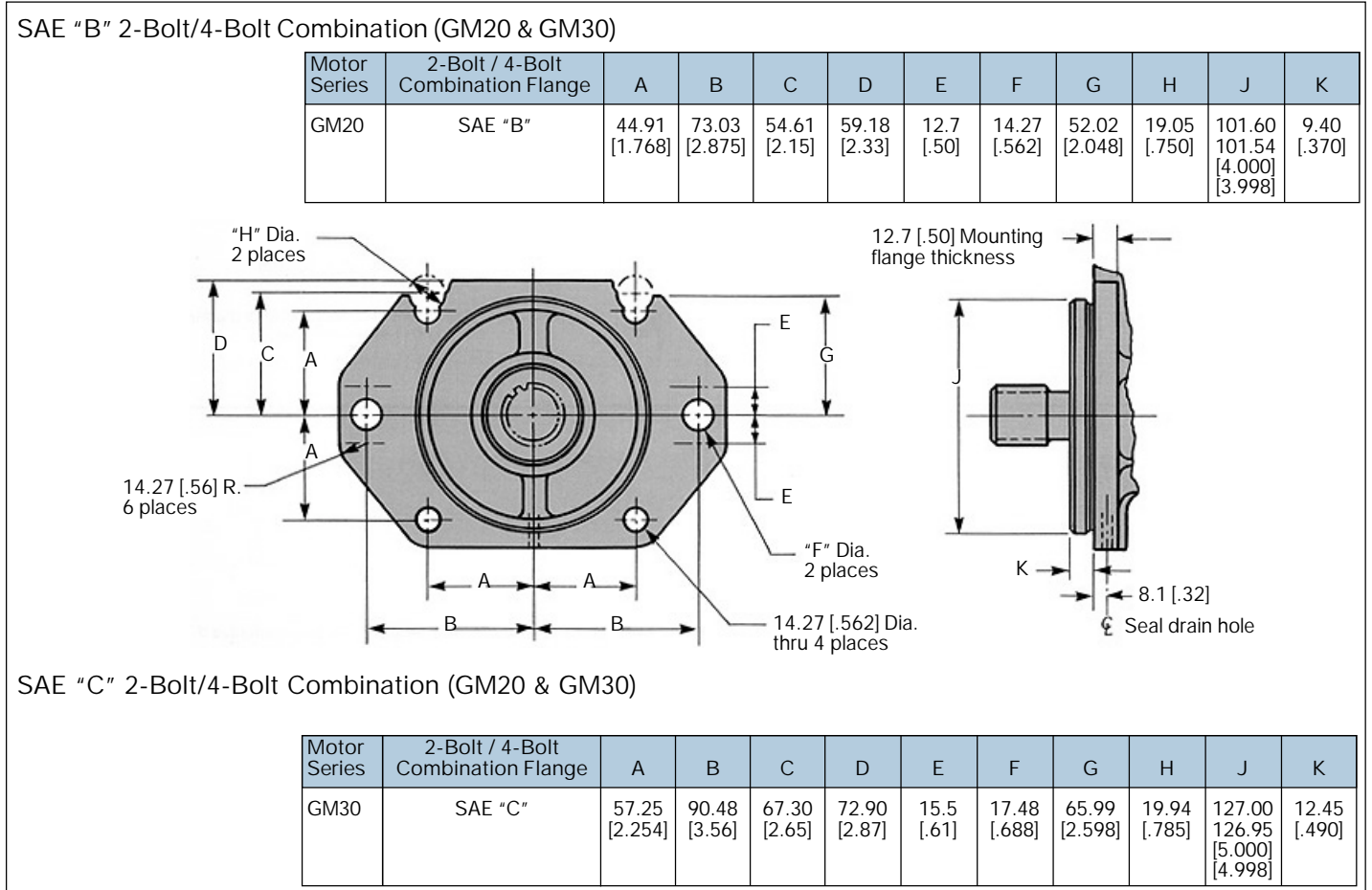
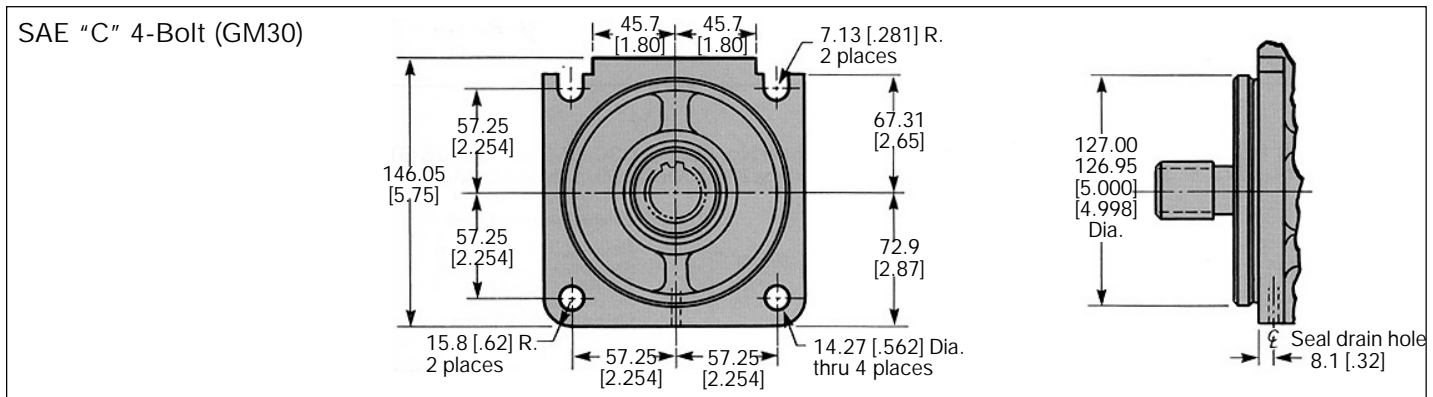
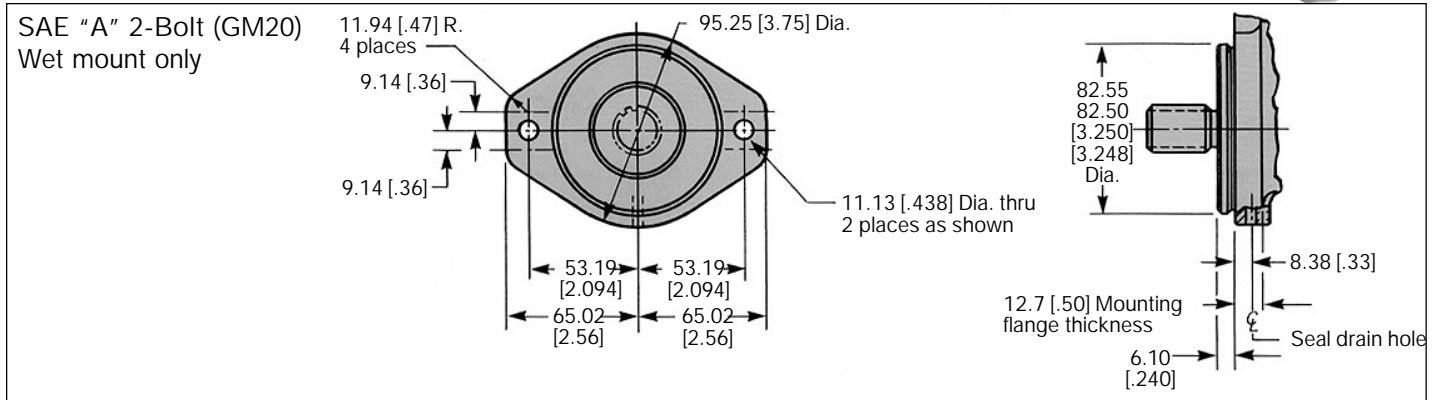

SAE "B" 2-Bolt (GM20) and SAE "C" 2-Bolt (GM30) flanges available, but not shown. Contact factory.



Drive Shafts for GM20 & GM30 Hydraulic Motors

Shaft No. 1: For GM20 motors.
292.6 Nm (2590 in. lb.) torsional capacity.*

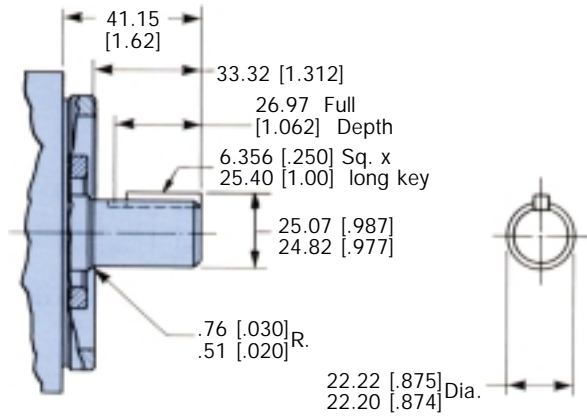

Shaft No. 1: For GM30 motors.
720.8 Nm (6380 in. lb.) torsional capacity.*

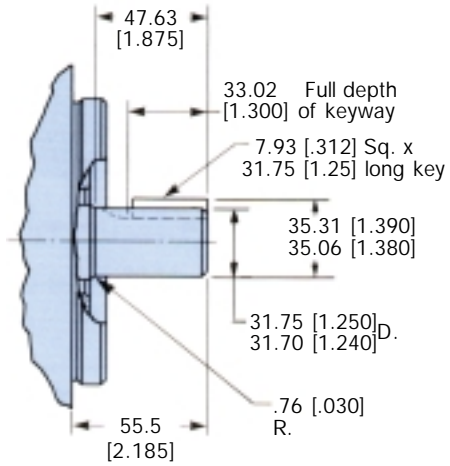

Shaft No. 5: For GM20 motors.

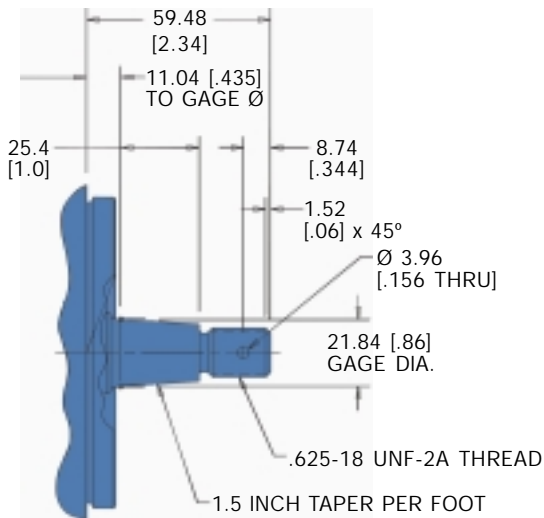

Shaft No. 5: For GM30 motors.

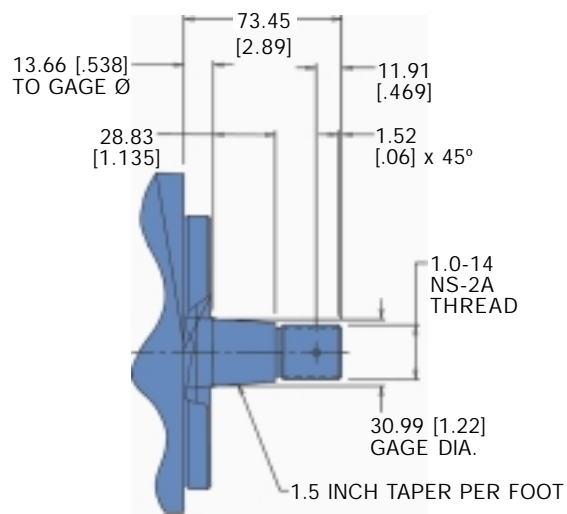

Shaft No. 12: For GM20 motors.
279.6 Nm (2475 in. lb.) torsional capacity.*

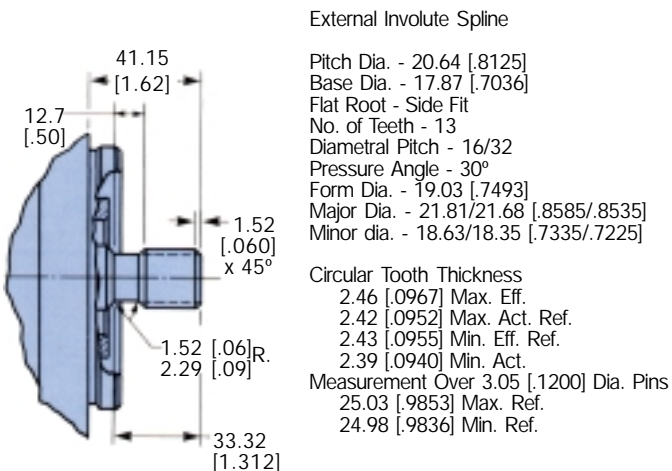

Shaft No. 12: For GM30 motors.
819.1 Nm (7250 in. lb.) torsional capacity.*

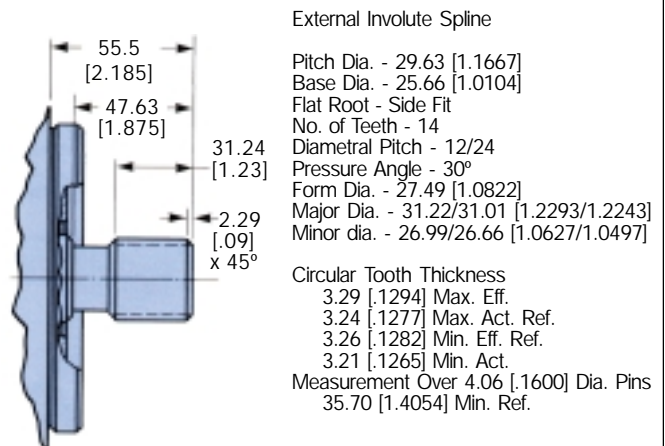

* Applies to coaxial applications only. Consult representative if application requires greater capacity or has side loads.

For shaft options not shown, contact factory for specific shaft information.

GM20 Performance Curves

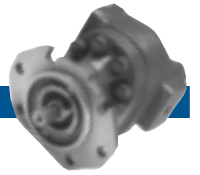

Note: All displacements are cc/rev.

GM20 Speed vs Flow at Maximum Pressure and 120°F using ISO VG 32 Fluid

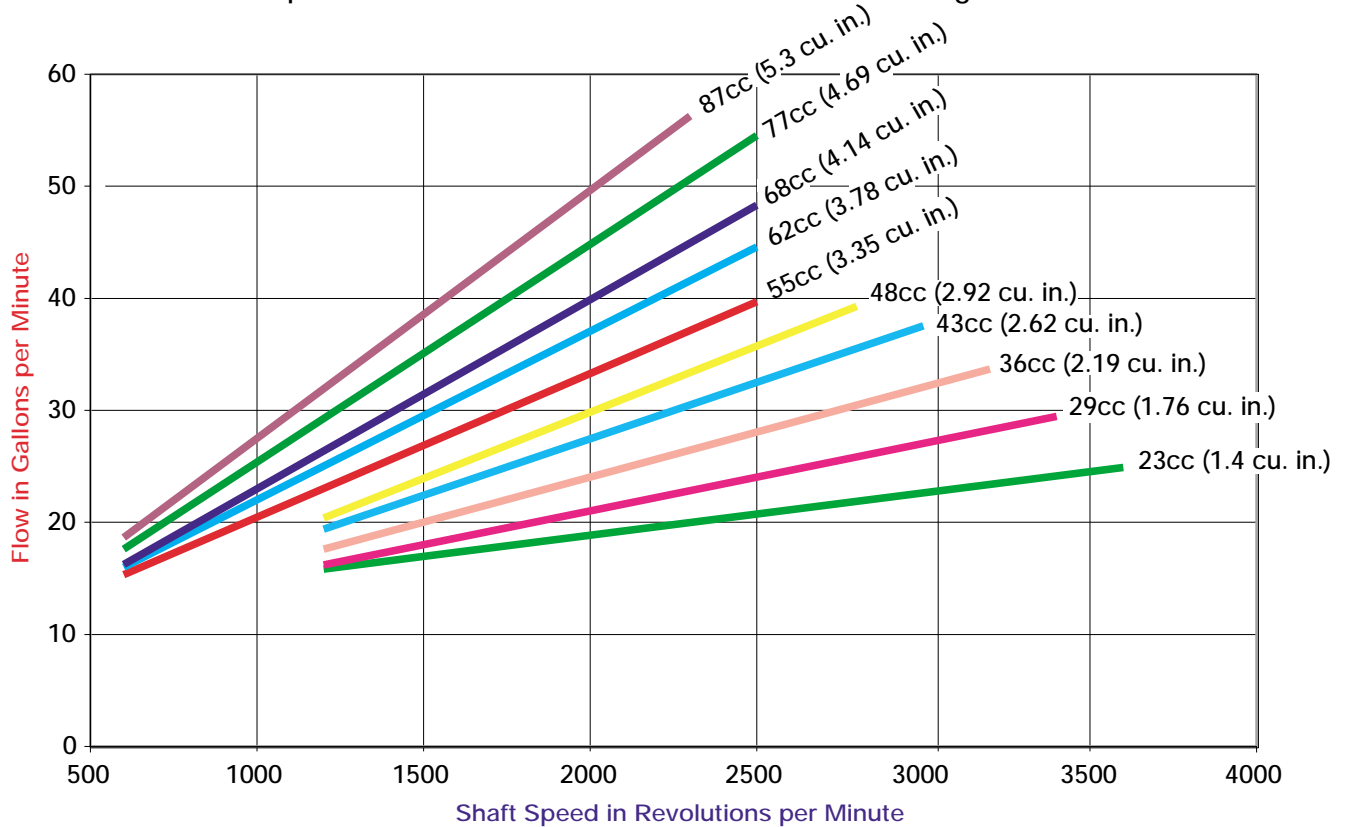

GM20 Pressure vs Torque at Maximum Speed and 120°F using ISO VG 32 Fluid

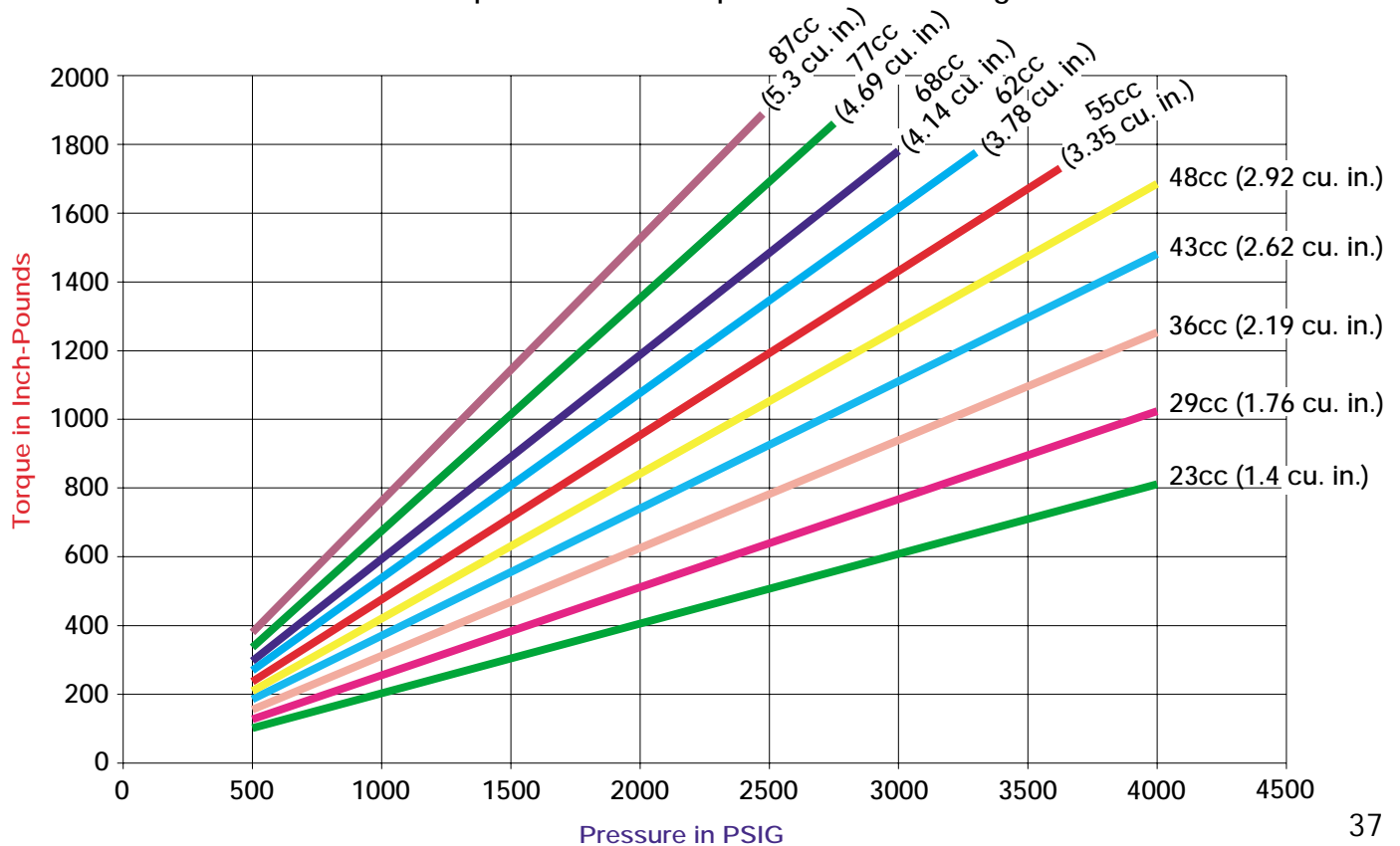



GM30 Performance Curves

Note: All displacements are cc/rev.

GM30 Speed vs Flow at Maximum Pressure and 120°F using ISO VG32 Fluid

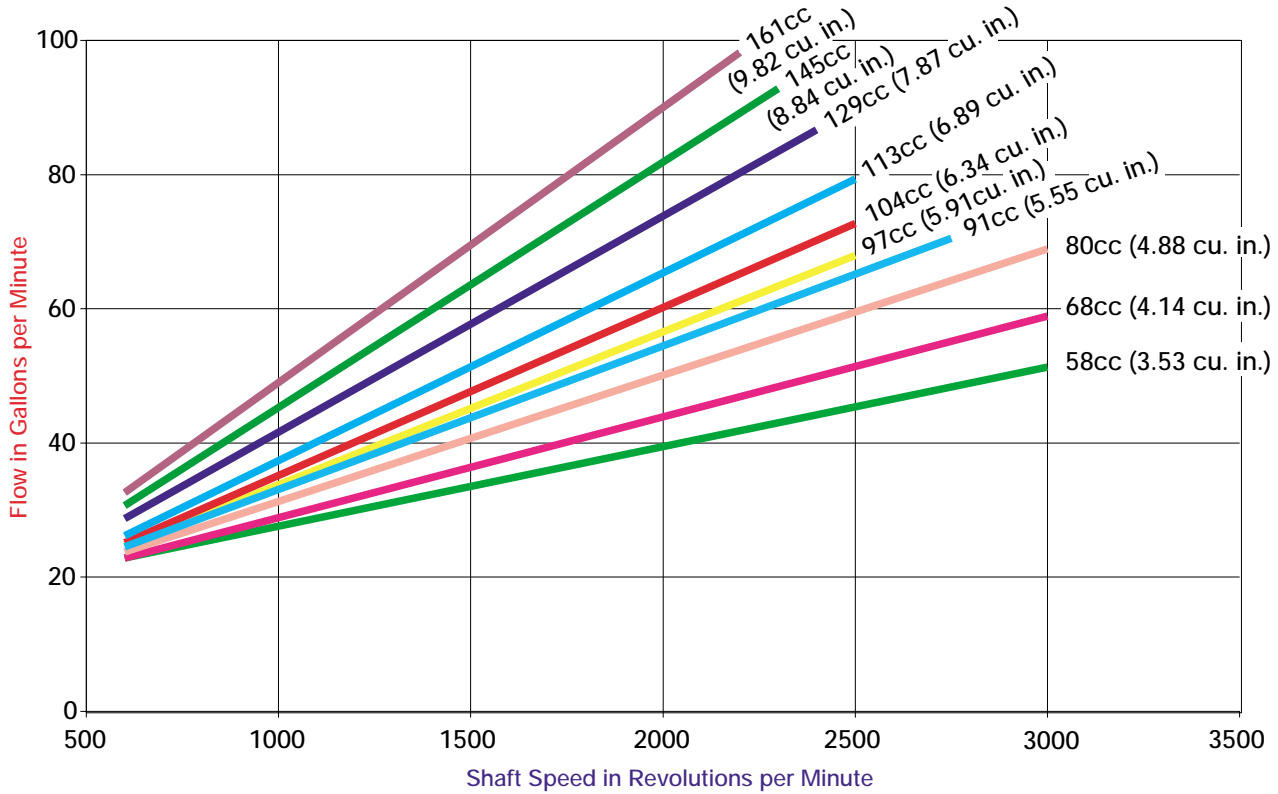

GM30 Pressure vs Torque at Maximum Speed and 120°F using ISO VG 32 Fluid

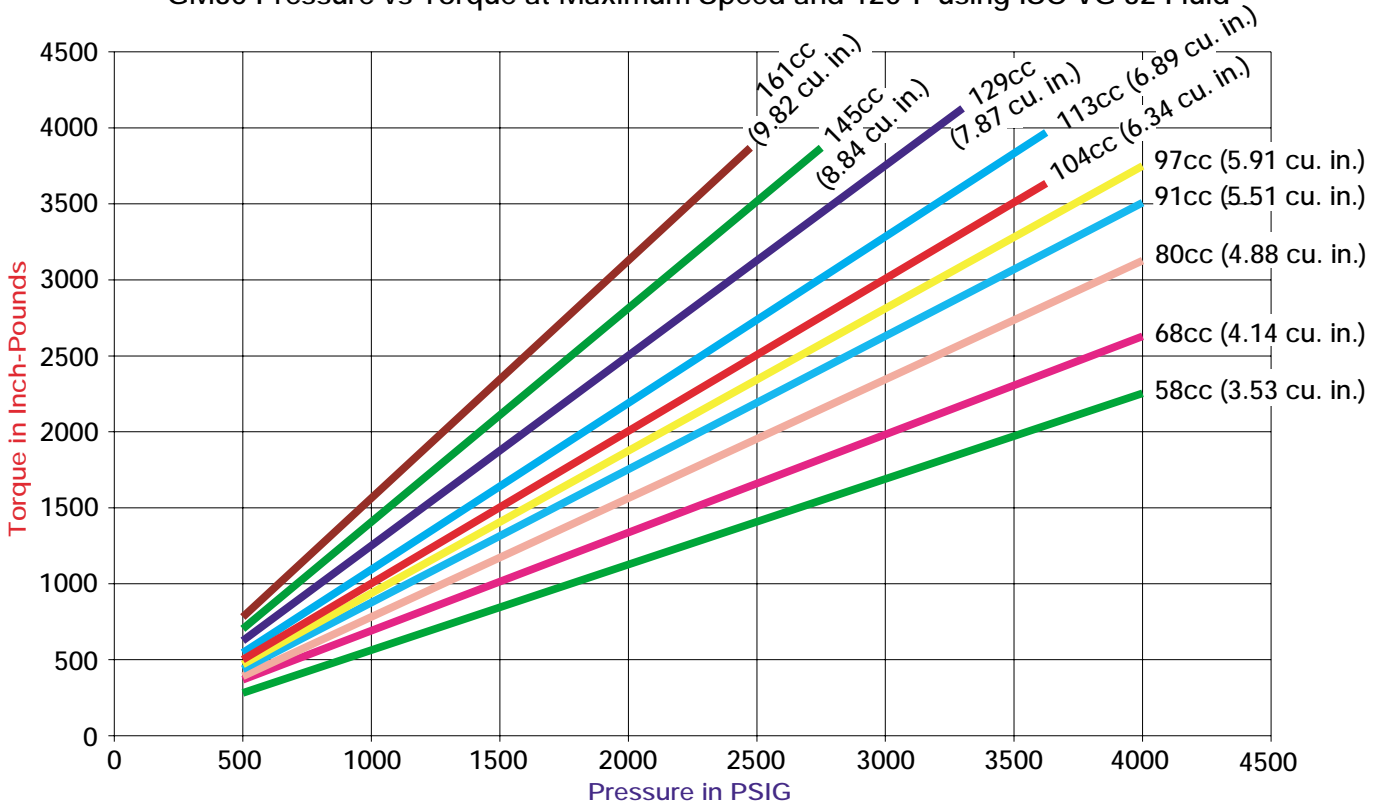

GM20 Axial/Radial Loads



Axial Loads for GM20

Consult representative if your application has axial loads.

MAXIMUM FLUID MOTOR RADIAL LOADS

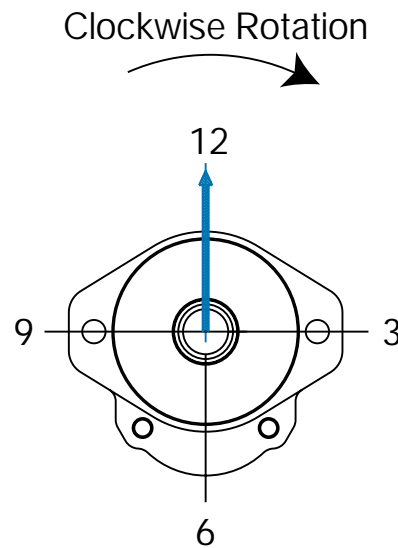

Pressure		Max. Radial Load at 12 O'Clock	
PSI	BAR	LBS	N
4000	275	430	1913

All values for 1" from mounting face.

For all other distances and angles, consult factory.

Higher radial loads may be allowable at lower operating pressures; consult factory.

GM20 Hydraulic Motor Pressure/Velocity Rating

Operation within the designed speed and pressure envelope will not exceed the pressure/velocity rating of the GM20 shaft seals.



GM30 Axial/Radial Loads

Axial Loads for GM30

Consult representative if your application has axial loads.

MAXIMUM FLUID MOTOR RADIAL LOADS

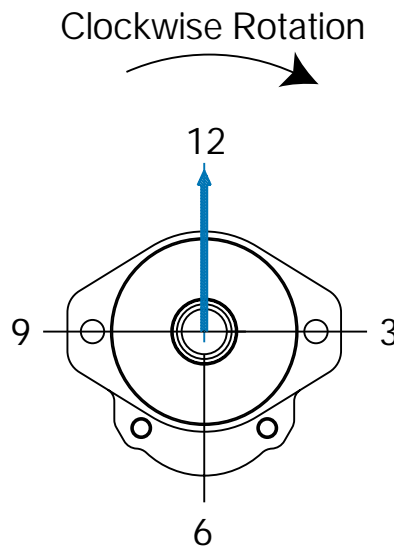

Pressure		Max. Radial Load at 12 O'Clock	
PSI	BAR	LBS	N
4000	275	710	3158

All values for 1" from mounting face.

For all other distances and angles, consult factory.

Higher radial loads may be allowable at lower operating pressures; consult factory.

GM30 Hydraulic Motor Pressure/Velocity Rating

Operation within the designed speed and pressure envelope will not exceed the pressure/velocity rating of the GM30 shaft seals.

GM20 Hydraulic Motor Order Code



Each option has been assigned an order code -- listed in the tables below -- for placement in the sequence shown at right.

1 (Special Seals)

Order Code	Description
F3	Viton Seal
Omit	Standard

2 (Series)

Order Code	Description
GM20	GM20 Series Unirotational Fluid Motor

3 (Mount Type)

Order Code	Description
D	Dry Mount Flange (shorter length, single shaft seal)
W	Wet Mount Flange (pilot diameter sealing and provides for optional double shaft seal)

4 (Front Cover)

Order Code	Description
1	SAE "A" 2-Bolt Mount
2	SAE "B" 2-Bolt Mount
6	SAE "B" 2/4-Bolt Combination Mount

5 (Inlet Port)

Order Code	Description
B	1.00", SAE 4-Bolt Split Flange
C	1.25", SAE 4-Bolt Split Flange
D	1.50", SAE 4-Bolt Split Flange
DM	1.50", 4-Bolt Metric Split Flange (M14 x 2.0 threads)
V	#16 SAE (1 5/16" - 12) Straight Thread
W	#20 SAE (1 5/8" - 12) Straight Thread
X	#24 SAE (1 7/8" - 12) Straight Thread

Contact factory for other requirements.

6 (Displacements)

Order Code	cm ³ /in ³	Order Code	cm ³ /in ³
7-23 cc,	1.41 in. ³ /rev.	17-55 cc,	3.33 in. ³ /rev.
9-29 cc,	1.79 in. ³ /rev.	19-62 cc,	3.77 in. ³ /rev.
11-36 cc,	2.18 in. ³ /rev.	21-68 cc,	4.13 in. ³ /rev.
13-43 cc,	2.60 in. ³ /rev.	24-77 cc,	4.71 in. ³ /rev.
15-48 cc,	2.94 in. ³ /rev.	27-87 cc,	5.30 in. ³ /rev.

7 (Outlet Port)

Order Code	Description
A	.750", SAE 4-Bolt Split Flange
B	1.00", SAE 4-Bolt Split Flange
BM	1.00", SAE 4-Bolt Metric Split Flange (M10 x 1.50 threads)
T	#12 SAE (1 1/16" - 12) Straight Thread
V	#16 SAE (1 5/16" - 12) Straight Thread

Contact factory for other requirements.

EXAMPLE:

F3-GM20-W-2-D-15-B-7-A-12-A-61-L

1	2	3	4	5	6	7	8	9	10	11	12	13
Special Seals	Series	Mount Type	Front Cover	Inlet Port	Displacements	Outlet Port	Rear Cover	Shaft Seal	Drive Shaft	Port Locations	Design	Rotation
F3	GM20	W	2	D	15	B	7	A	12	A	61	L

8 (Rear Cover)

Order Code	Description
1	Standard Single Pump Rear Cover (no options)
7	Case Drain Rear Cover

9 (Shaft Seal)

Order Code	Description
A	Single Shaft Seal
B	Double Shaft Seal

10 (Drive Shaft)

Order Code	Description
1	SAE "B" Straight Keyed, .875" diameter, 1.312" ext.
5	Tapered Keyless/Threaded (.625" - 18 UNC, 1.50" taper per ft)
7	Tapered Keyed/Threaded (.625" - 18 UNC, 1.50" taper per ft)
11	SAE "B" 13-Tooth Spline, Major Diameter Fit
12	SAE "B" 13-Tooth Spline, Flat Root - Side Fit
19	SAE "A" 9-Tooth Spline, Flat Root - Side Fit
21	SAE "BB" Straight Keyed, 1.00" diameter, 1.50" ext.

Contact factory for other requirements.

11 (Port Locations)

Order Code	Description
A	Side Inlet / Side Outlet
B	Side Inlet / Rear Outlet
C	Rear Inlet / Side Outlet
D	Rear Inlet / Rear Outlet

12 (Design Designation)

Order Code	Description
61	Standard (61 st Design)

13 (Rotation)

Order Code	Description
R	Clockwise Rotation
L	Counterclockwise Rotation



GM30 Hydraulic Motor Order Code

Each option has been assigned an order code -- listed in the tables below -- for placement in the sequence shown at right.

1 (Special Seals)

Order Code	Description
F3	Viton Seal
Omit	Standard

2 (Series)

Order Code	Description
GM30	GM30 Series Motor

3 (Mount Type)

Order Code	Description
C	Standard Designation

4 (Front Cover)

Order Code	Description
4	SAE "C" 4-Bolt Mount
6	SAE "B" 2/4-Bolt Combination Mount
7	SAE "C" 2-Bolt Mount
8	SAE "C" 2/4-Bolt Combination Mount

5 (Inlet Port)

Order Code	Description
D	1.50", SAE 4-Bolt Split Flange
DM	1.50", 4-Bolt Metric Split Flange (M14 x 2.0 threads)
E	2.00", SAE 4-Bolt Split Flange
EM	2.00", 4-Bolt Metric Split Flange (M14 x 2.0 threads)
W	#20 SAE (1 5/8" - 12) Straight Thread
X	#24 SAE (1 7/8" - 12) Straight Thread
Y	#30 SAE (2 1/2" - 12) Straight Thread

Contact factory for other requirements.

6 (Displacements)

Order Code	cm ³ /in ³	Order Code	cm ³ /in ³
18-	58 cc, 3.54 in. ³ /rev.	32-	104 cc, 6.30 in. ³ /rev.
21-	68 cc, 4.13 in. ³ /rev.	35-	113 cc, 6.88 in. ³ /rev.
25-	80 cc, 4.91 in. ³ /rev.	40-	129 cc, 7.86 in. ³ /rev.
28-	91 cc, 5.51 in. ³ /rev.	45-	145 cc, 8.84 in. ³ /rev.
30-	97 cc, 5.89 in. ³ /rev.	50-	161 cc, 9.82 in. ³ /rev.

7 (Outlet Port)

Order Code	Description
B	1.00", SAE 4-Bolt Split Flange
BM	1.00", SAE 4-Bolt Metric Split Flange (M10 x 1.50 threads)
C	1.25", SAE 4-Bolt Split Flange
CM	1.25", 4-Bolt Metric Split Flange (M12 x 1.75 threads)
D	1.50", SAE 4-Bolt Split Flange
DM	1.50", 4-Bolt Metric Split Flange (M14 x 2.0 threads)
W	#20 SAE (1 5/8" - 12) Straight Thread
X	#24 SAE (1 7/8" - 12) Straight Thread

Contact factory for other requirements.

EXAMPLE:

F3-GM30-C-4-D-18-B-7-A-12-A-32-L												
1	2	3	4	5	6	7	8	9	10	11	12	13
Special Seals	Series	Mount Type	Front Cover	Inlet Port	Displacements	Outlet Port	Rear Cover	Shaft Seal	Drive Shaft	Port Locations	Design	Rotation
F3	GM30	C	4	D	18	B	7	A	12	A	32	L

8 (Rear Cover)

Order Code	Description
2	Standard Single Pump Rear Cover (no options)
7	External Drain

9 (Shaft Seal)

Order Code	Description
A	Single Shaft Seal
B	Double Shaft Seal
C	None

10 (Drive Shaft)

Order Code	Description
1	SAE "C" Straight Keyed, 1.250" diameter, 1.875" ext.
5	Tapered Keyless/Threaded (1.0" - 14 NS, 1.50" taper per ft)
12	SAE "C" 14-Tooth Spline, Flat Root - Side Fit
18	SAE "B" 13-Tooth Spline, Flat Root - Side Fit (contact factory)
34	SAE "C" 14-Tooth Spline, Major Diameter Fit

Contact factory for other requirements.

11 (Port Locations)

Order Code	Description
A	Side Inlet / Side Outlet
B	Side Inlet / Rear Outlet
C	Rear Inlet / Side Outlet
D	Rear Inlet / Rear Outlet

12 (Design Designation)

Order Code	Description
32	32 nd Design

13 (Rotation)

Order Code	Description
R	Clockwise Rotation
L	Counterclockwise Rotation

GM25 Series Birotational Hydraulic Motors



GM25 Series hydraulic motors are designed for low noise, high efficiency birotational operation. Cast iron construction insures reliability and strength. A number of flange, shaft, seal and porting options are available.

GM25 Motor Dimensional Information

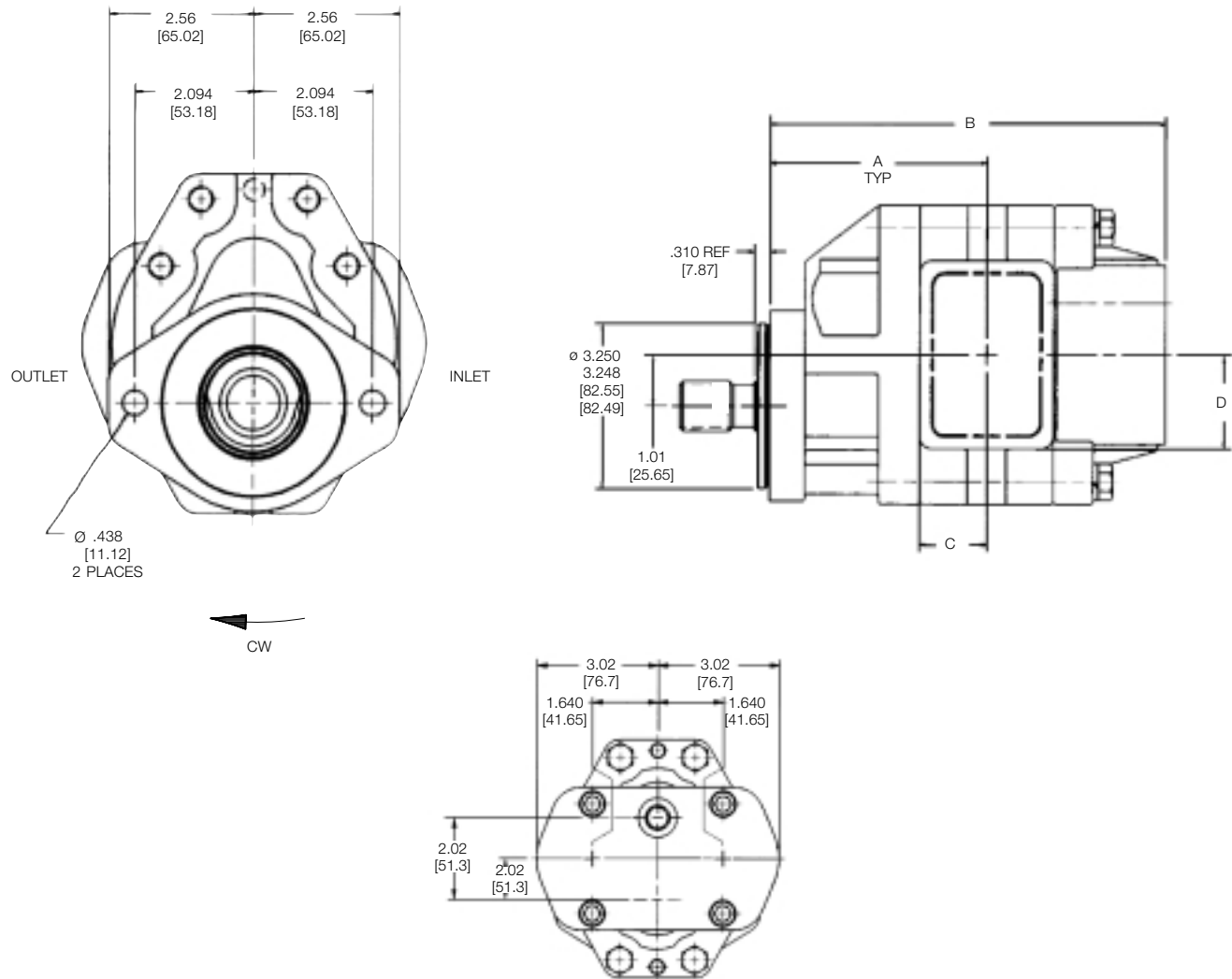

Model	"A" Inch (mm)	"B" Inch (mm)	"C" Inch (mm)	"D" Inch (mm)
GM25-23-**-**-**F*F*-20-*	3.57 [90.8]	6.44 [163.5]	.71 [18.0]	1.28 [32.5]
GM25-29-**-**-**F*F*-20-*	3.65 [92.8]	6.60 [167.6]	.79 [20.1]	1.28 [32.5]
GM25-36-**-**-**F*F*-20-*	3.74 [94.9]	6.76 [177.8]	.87 [22.1]	1.28 [32.5]
GM25-43-**-**-**F*F*-20-*	3.83 [97.2]	6.94 [176.3]	.96 [24.4]	1.28 [32.5]
GM25-48-**-**-**F*F*-20-*	3.90 [99.0]	7.08 [180.0]	1.03 [26.2]	1.38 [35.0]
GM25-55-**-**-**F*F*-20-*	3.98 [101.1]	7.25 [184.2]	1.11 [28.2]	1.56 [39.6]
GM25-62-**-**-**F*F*-20-*	4.07 [103.5]	7.44 [188.9]	1.26 [32.0]	1.56 [39.6]
GM25-68-**-**-**F*F*-20-*	4.15 [105.4]	7.58 [192.7]	1.28 [32.5]	1.85 [47.0]
GM25-77-**-**-**F*F*-20-*	4.27 [108.5]	7.83 [199.0]	1.41 [35.8]	1.85 [47.0]
GM25-87-**-**-**F*F*-20-*	4.40 [111.7]	8.08 [205.3]	1.53 [38.9]	2.00 [50.8]



GM25 Series Performance Data

Note: All displacements are cc/rev.

GM25 Speed vs Flow at 120°F using ISO VG 32 Fluid

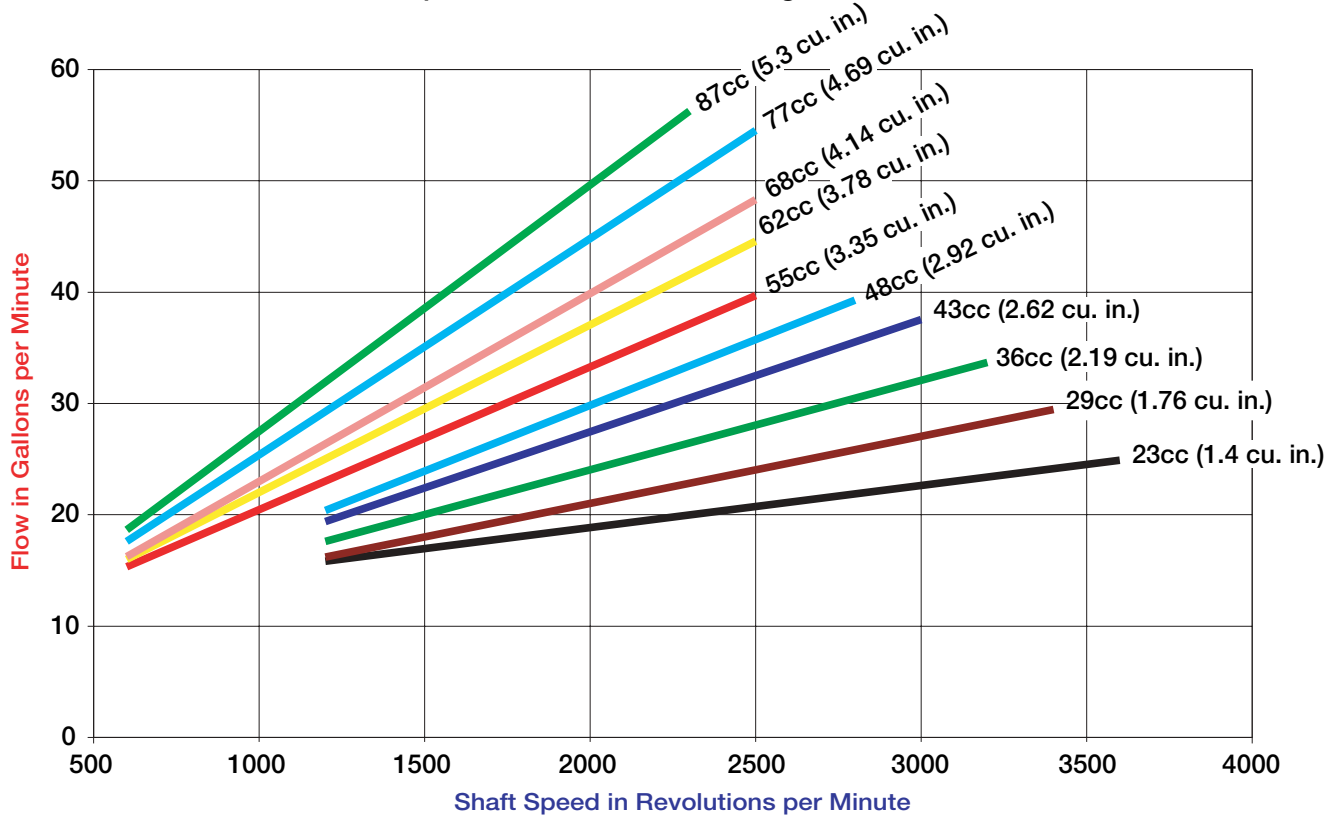

GM25 Pressure vs Torque at Maximum Speed and 120°F using ISO VG 32 Fluid

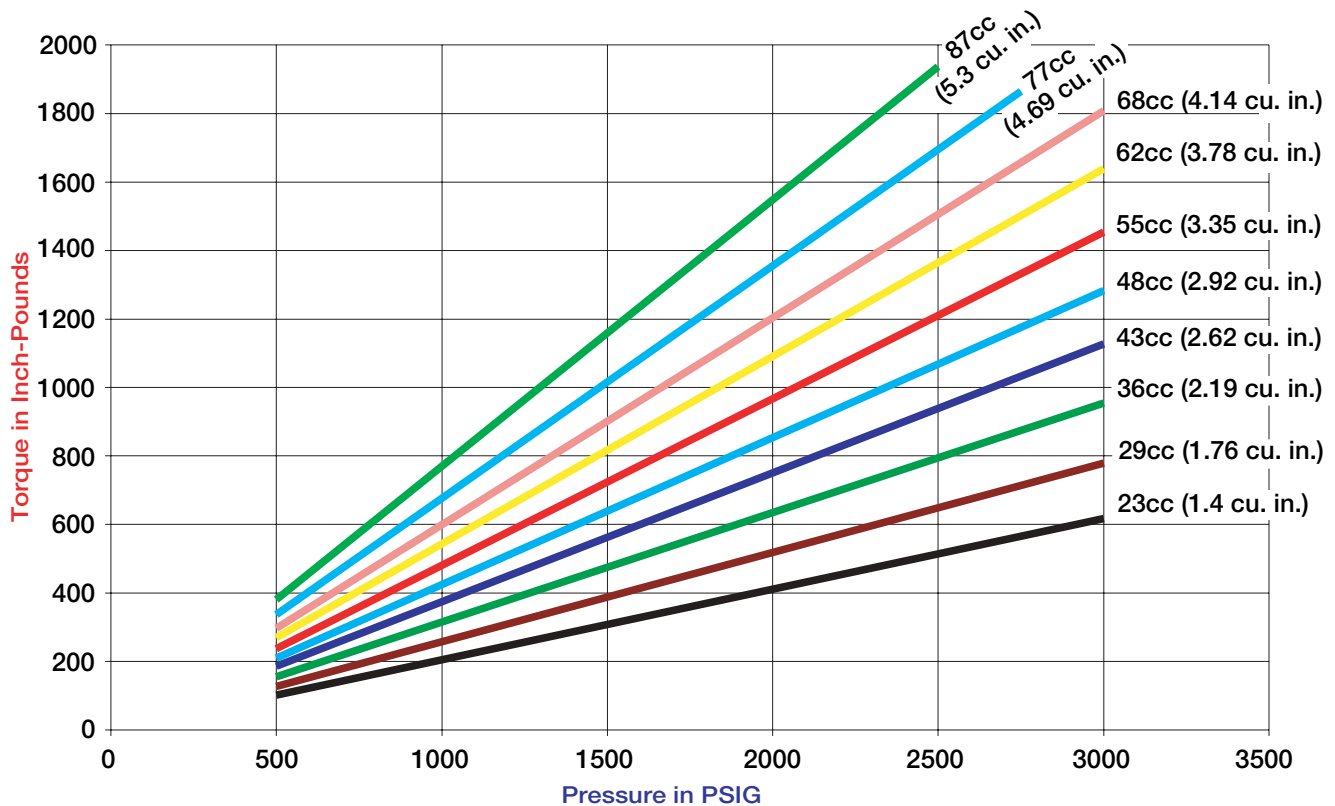

GM25 Series Motor Starting Characteristics



Note: All displacements are cc/rev.

GM25 Starting Torque
100°F using ISO VG 32 Fluid

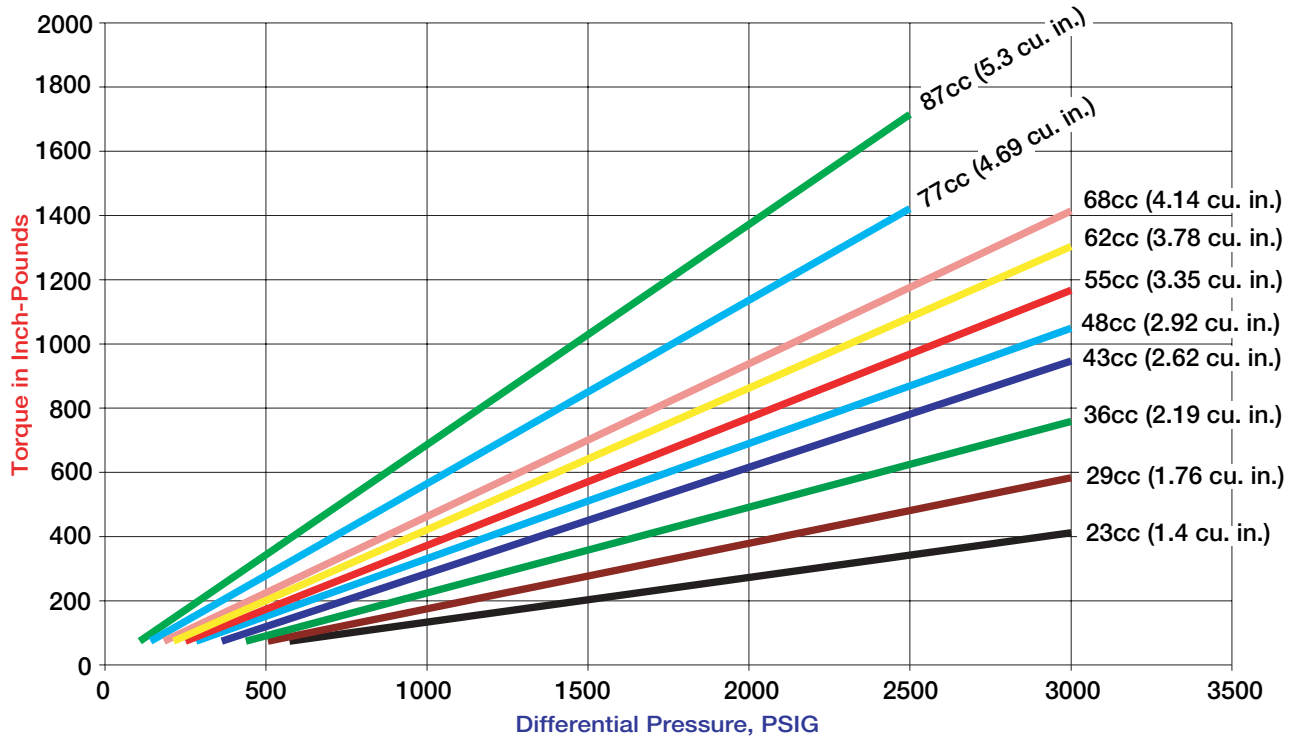

Mounting Flanges for GM25 Hydraulic Motors

See additional flange options on page 46.

Option 1 2-Bolt SAE "A"

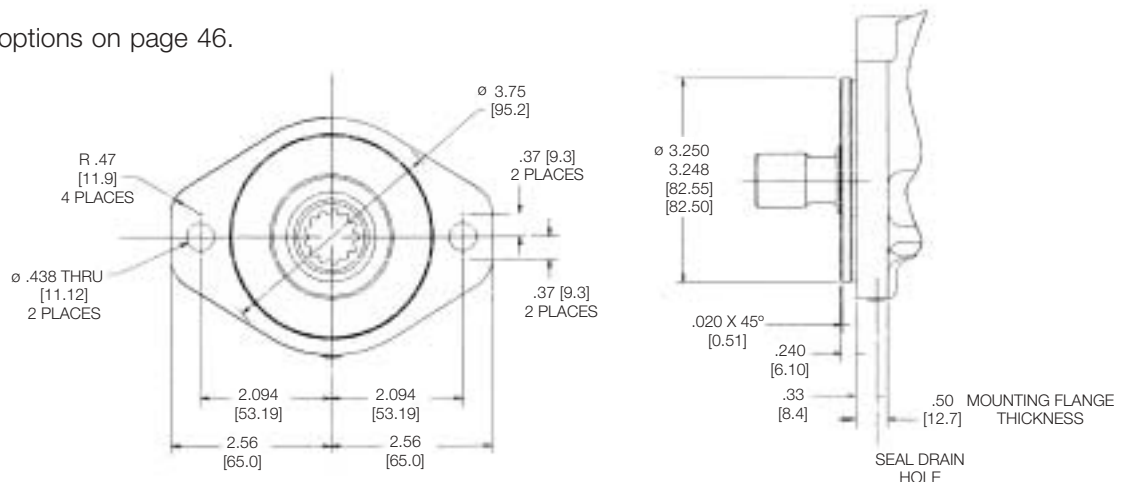



Mounting Flanges for GM25 Hydraulic Motors

Option 2 2-Bolt SAE "B"

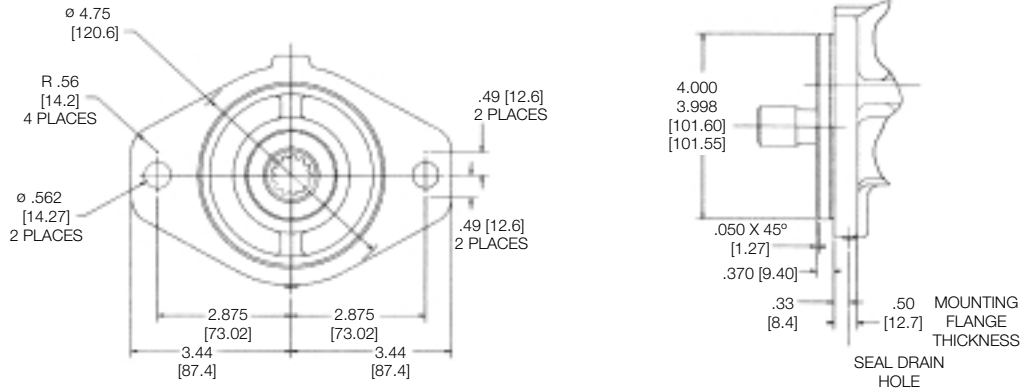

Drive Shafts for GM25 Hydraulic Motors

Shaft No. 1: SAE "B" Straight Keyed (.875" dia., 1.312" ext.)

292.6 Nm (2590 in. lb.) torsional capacity.*

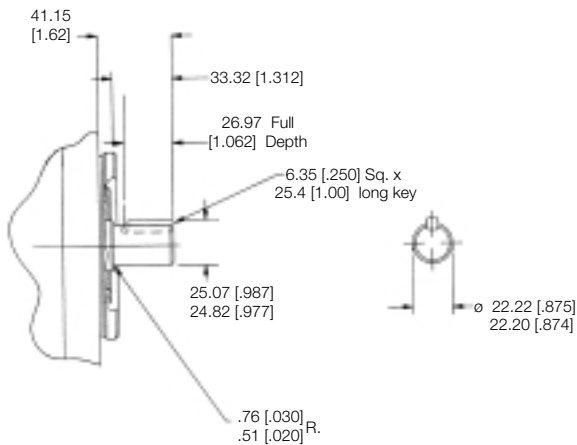

Shaft No. 12: SAE "B" 13 Tooth Spline (Flat Root - Side Fit)

279.6 Nm (2475 in. lb.) torsional capacity.*

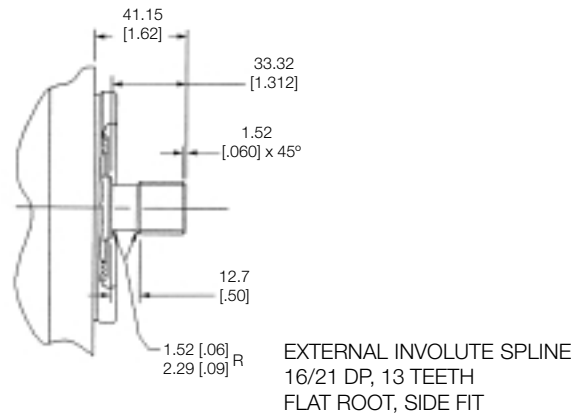

Shaft No. 5: Tapered Keyless/Threaded (.625"-18 UNC, 1.50" taper per ft)

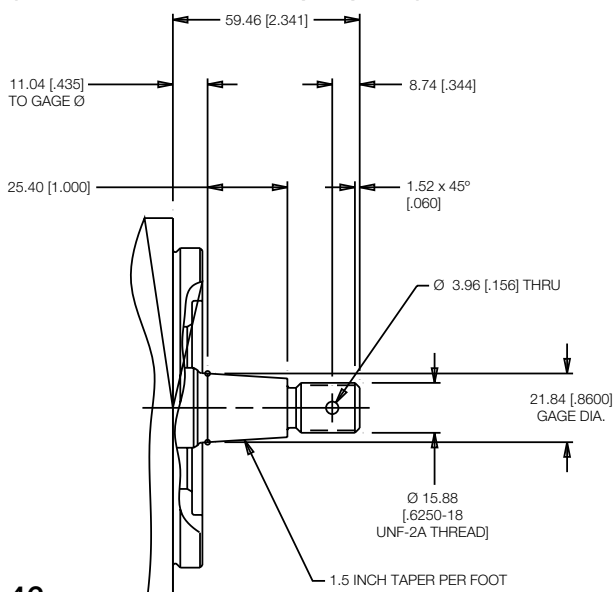

Shaft No. 19: SAE "A" 9 Tooth Spline (Flat Root - Side Fit)

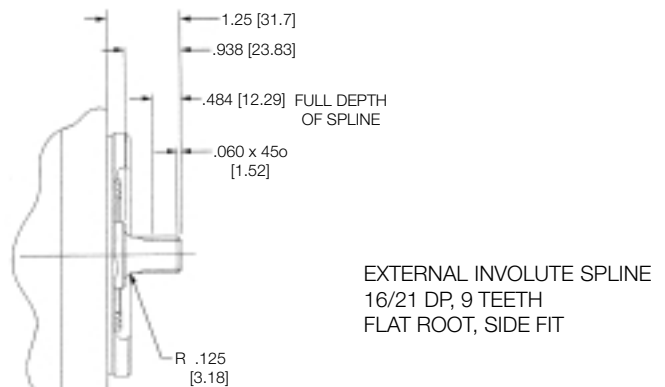

Drive Shafts for GM25 Hydraulic Motors (cont.)



**Shaft No. 21: SAE "BB" Straight Keyed
(1" dia., 1.50" ext.)**

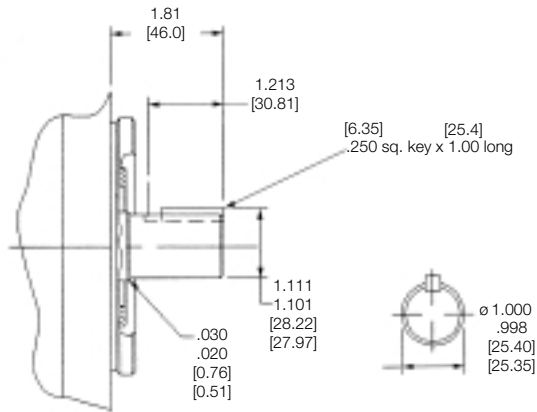

**Shaft No. 99: SAE "BB" 15 Tooth Spline
(Flat Root - Side Fit)**

451.9 Nm (4000 in. lb.) torsional capacity.*

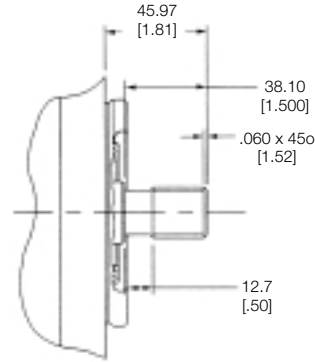

EXTERNAL INVOLUTE SPLINE
16/21 DP, 15 TEETH
FLAT ROOT, SIDE FIT

Port Size & Location Selection Guide

The chart below indicates the port styles and sizes available for a given displacement and port location.

Displacement	Side & Rear Inlet/ Side & Rear Outlet	Side Inlet / Side Outlet	Rear Inlet/ Rear Outlet	Port Description Key
23	K, Q	K, Q	A, AM, B, BM, C, CM, K, L, M, Q, S, T, U, V, W	A = 4-Bolt, .75" B = 4-Bolt, 1"
29	K, L, Q, S	K, L, Q, S	A, AM, B, BM, C, CM, K, L, M, Q, S, T, U, V, W	C = 4-Bolt, 1.25"
36	K, L, S	K, L, S	A, AM, B, BM, C, CM, K, L, M, S, T, U, V, W	D = 4-Bolt, 1.5"
43	K, L, M, S, T	K, L, M, S, T	A, AM, B, BM, C, CM, K, L, M, S, T, U, V, W	L = 1" NPTF
48	K, L, M, S, T, U, V	A, AM, K, L, M, S, T, U	A, AM, B, BM, C, CM, K, L, M, S, T, U, V, W	M = 1.25" NPTF
55	K, L, M, T, U, V	A, AM, B, BM, K, L, M, T, U, V	A, AM, B, BM, C, CM, K, L, M, T, U, V, W	Q = .75" - 12
62	K, L, M, T, U, V	A, AM, B, BM, C, CM, K, L, M, T, U, V	A, AM, B, BM, C, CM, K, L, M, T, U, V, W	S = .875" - 12
68	K, L, M, T, U, V, W	A, AM, B, BM, C, CM, K, L, M, T, U, V, W	A, AM, B, BM, C, CM, K, L, M, T, U, V, W	T = 1.0625" - 12
77	L, M, T, U, V, W	C, CM, D, DM, L, M, T, U, V, W, X	B, BM, C, CM, L, M, T, U, V, W	U = 1.1875" - 12
87	L, M, U, V, W	C, CM, D, DM, L, M, U, V, W, X	B, BM, C, CM, L, M, U, V, W	V = 1.3125" - 12
				W = 1.625" - 12
				X = 1.875" - 12



GM25 Hydraulic Motor Axial/Radial Loads

Axial Loads for GM25

Consult representative if your application has axial loads.

Maximum Fluid Motor Radial Loads

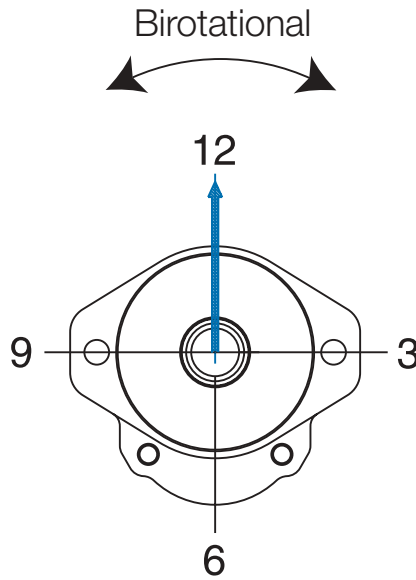

Pressure		Max. Radial Load at 12 O'Clock	
PSI	BAR	LBS	N
0-2250	0-155	500	2224

All values for 1" from mounting face.

For all other distances and angles, consult factory.

Higher radial loads may be allowable at lower operating pressures; consult factory.

GM25 Hydraulic Motor Pressure/Velocity Rating

Operation within the designed speed and pressure envelope will not exceed the pressure/velocity rating of the GM25 shaft seals.

GM25 Hydraulic Motor Order Code



ORDERING INFORMATION

Each option has been assigned an order code -- listed in the tables below -- for placement in the sequence shown at right.

1 (Pump Type)

Order Code	Description
GM	Gear Motor

2 (Pump Series)

Order Code	Description
25	G25 Series

3 (Shaft Seal Material)

Order Code	Description
B	Buna N
V	Viton

4 (Mounting Flange)

Order Code	Description
1	2-Bolt SAE "A"
2	2-Bolt SAE "B"

5 (Port Style & Size)

Order Code	Description
A	4-Bolt Flange, 0.75" Dia.
B	4-Bolt Flange, 1.00" Dia.
C	4-Bolt Flange, 1.25" Dia.
D	4-Bolt Flange, 1.50" Dia.
L	1.00" NPTF
M	1.25" NPTF
Q	.750" - 12 Straight Thread
S	.875" - 12 Straight Thread
T	1.0625" - 12 Straight Thread
U	1.1875" - 12 Straight Thread
V	1.3125" - 12 Straight Thread
W	1.6250" - 12 Straight Thread
X	1.8750" - 12 Straight Thread

6 (Displacement)

Order Code	Description
23	23 cc / 1.4 in. ³
29	29 cc / 1.76 in. ³
36	36 cc / 2.19 in. ³
43	43 cc / 2.62 in. ³
48	48 cc / 2.92 in. ³
55	55 cc / 3.35 in. ³
62	62 cc / 3.78 in. ³
68	68 cc / 4.14 in. ³
77	77 cc / 4.69 in. ³
87	87 cc / 5.3 in. ³

EXAMPLE:

GM25-B-2- T- 55-B-12-A-20-B- XXX

1	2	3	4	5	6	7	8	9	10	11	12
Pump Type	Pump Series	Shaft Seal Material	Mounting Flange	Port Size	Pump Displacement	Shaft Seal	Shaft Type	Port Locations	Design Series	Rotation	Special Design
GM	25	B	1	5	55	B	12	A	20	B	XXX

7 (Shaft Seal)

Order Code	Description
A	Single Seal
B	Double Seal
C	Single Seal with Outboard Bearing

8 (Shaft Type)

Order Code	Description
1	SAE "B" Straight Keyed, .875" dia., 1.312" ext.
5	Tapered Keyless/Threaded (.625" - 18 UNC, 1.50" taper per ft)
12	SAE "B" 13 Tooth Spline (Flat Root-Side Fit)
19	SAE "A" 9-Tooth Spline (Flat Root-Side Fit)
21	SAE "BB" Straight Keyed 1" dia., 1.50" ext.
99	SAE "BB" 15 Tooth Spline (Flat Root-Side Fit)

Contact factory for other options.

9 (Port Locations)

Order Code	Description
A	Side & Rear Inlet / Side & Rear Outlet *
B	Side Inlet / Side Outlet **
C	Rear Inlet / Rear Outlet **
D	Same as Option A, except with Case Drain
E	Same as Option B, except with Case Drain **
F	Same as Option C, except with Case Drain **

* NOTE: Port Location "A" not available with port size "X" on displacements "77" or "87" cc.

** Split flange option available on rear only or side only.

10 (Design Series)

Order Code	Description
20	Design Series

11 (Rotation)

Order Code	Description
B	Birotational

12 (Special)

Order Code	Description
xxx	Special Design Designation

Hydraulic Spindle Motors

Hydraulic Blade Drive Systems for Rotary Turf Mowers

Compared to Mechanical Drive Systems, hydraulic spindle motors have no belts to adjust or replace resulting in less down time, lower maintenance costs; excellent in wet conditions; no belt slippage; faster cutting; no belt stretching; allows for flexibility in mower design with no belts to accommodate; and fewer components make for a lighter weight system. Contact Haldex regarding your spindle motor application.

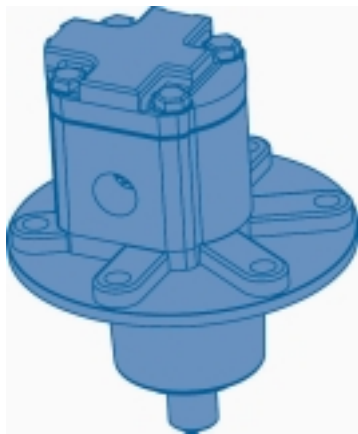
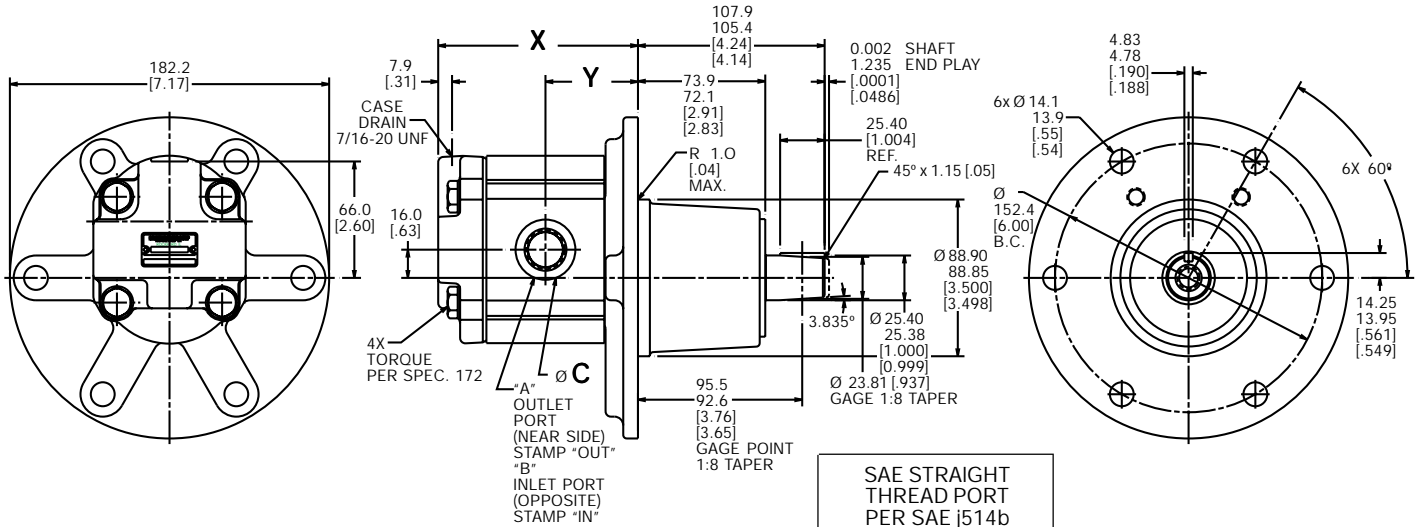

PATENT 6,010,321

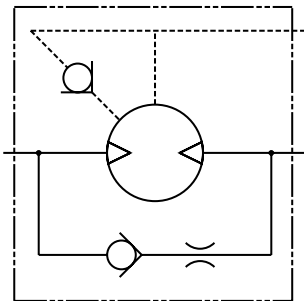

Order Code	Displacement		"A" Size	"B" Size	Ø C Min.	"X" Max.	"Y" Port Centerline	Approx. Wt./kg [lbs.]			
	cm ³	in ³									
06	6.0	0.37	3/4-16	3/4-16	30.18 [1.188]	98.58 [3.881]	44.63 [1.757]	5.30 [11.65]			
07	7.0	0.43				100.08 [3.940]	45.38 [1.786]	5.35 [11.76]			
08	8.0	0.49				101.58 [3.999]	46.13 [1.816]	5.41 [11.89]			
09	9.0	0.55				102.98 [4.054]	46.83 [1.844]	5.47 [12.03]			
10	10.0	0.61				104.48 [4.113]	47.58 [1.873]	5.53 [12.16]			
11	11	11.0				105.98 [4.172]	48.33 [1.903]	5.58 [12.27]			
12	12.0	0.74				107.43 [4.229]	49.15 [1.935]	5.64 [12.40]			
13	13.0	0.80				108.98 [4.290]	49.90 [1.965]	5.70 [12.53]			
14	14.0	0.86				110.48 [4.349]	50.65 [1.994]	5.76 [12.66]			
15	15.0	0.92				111.88 [4.405]	51.35 [2.022]	5.81 [12.77]			
16	16.0	0.98				113.38 [4.464]	52.10 [2.051]	5.87 [12.91]			
17	17.0	1.04				114.88 [4.523]	52.85 [2.081]	5.94 [13.06]			
18	18.0	1.10				116.38 [4.582]	53.60 [2.110]	5.98 [13.15]			
19	19.0	1.17				7/8-14	7/8-14	34.14 [1.344]	117.88 [4.641]	54.35 [2.140]	6.04 [13.28]
20	20.0	1.23							119.38 [4.700]	55.10 [2.169]	6.10 [13.41]
21	21.0	1.29	120.78 [4.755]	55.80 [2.197]	6.16 [13.54]						
22	22.0	1.35	122.28 [4.814]	56.25 [2.215]	6.21 [13.65]						
23	23.0	1.41	123.78 [4.873]	57.23 [2.253]	6.27 [13.79]						
24	24.0	1.47	1 1/16-12	1 1/16-12	41.27 [1.626]	125.28 [4.932]	57.98 [2.282]	6.33 [13.92]			
25	25.0	1.53				126.78 [4.991]	58.73 [2.312]	6.39 [14.05]			
26	26.0	1.60				128.28 [5.050]	59.48 [2.342]	6.44 [14.16]			
27	27.0	1.66				129.68 [5.105]	60.48 [2.381]	6.50 [14.29]			
28	28.0	1.72				131.18 [5.164]	60.93 [2.399]	6.56 [14.42]			

Only Haldex offers this extensive range of pumps, hydraulic motors, power units and flow dividers worldwide.

GC Series Hydraulic Pumps

Compact cast iron gear pumps with a wide variety of integrated options provide custom systems capability and high-efficiency performance. Displacements from 0.065 to 0.711 cu. in. (1.066 to 11.65 cc) per revolution. Pressures to 4,000 psi (275 Bar).

W Series Gear Pumps

Highly efficient pumps feature 4,000 psi continuous operation, speed range from 500 to 4,000 rpm, low noise operation and overall efficiency greater than 90%. Displacements from .183 to 3.05 cu. in. (3 to 50 cc) per revolution. Other features include SAE, ISO and DIN shafts, flanges and ports; integrated valves and multiple pump configurations.

G20-LS/G-30LS Load Sense Variable Discharge Gear Pumps

Offers the horsepower conservation of a load sense system and the low cost reliability of a gear pump. Featuring cast iron construction and 4,000 psi continuous operation for severe-duty applications. Displacements from 1.41 to 9.82 cu. in. (23 to 161 cc).

G20 & G30 Series Gear Pumps

Rugged cast iron pumps offer high performance for severe-duty applications. Available in single, multiple and through-drive versions. Displacements from 1.41 to 9.82 cu. in. (23 to 161 cc) per revolution. Pressures to 4,000 psi (275 Bar) continuous.

G20 / G30 Specialty Products

- G20-DM Pump/Motor Series, G20 series pump with direct mount motor options. Motor options --- 7.5 HP, 10 HP, and 15 HP and displacements from 1.41 to 2.94 cu. in. (23 to 48 cc) for pump/motor units. Integral manifold options also available.
- G20 / G30 PTO Pump Series. Specifically designed pump options and features for PTO (power take off) applications. Displacements from 1.41 to 9.82 cu. in. (23 to 161 cc).
- G20 / G30 two section flow dividers. Displacements from 1.41 to 9.82 cu. in. (23 to 161 cc) per section. Pressures to 4,000 psi continuous (275 Bar).

Gerotor Pumps

High-efficiency, low-maintenance design with quiet operation and uniform flow. Extremely tolerant of contamination. Displacements from 0.05 to 8.29 cu. in. (0.8 to 135.8 cc) per revolution. Pressures to 2,000 psi (136 Bar).

GC-9500 AC Hydraulic Power Units

AC power units offering the ultimate in design versatility and ordering flexibility. It can be ordered completely assembled or in kits. Standard options include: motors (1/2-5 hp, TEFC, open, and drip-proof); 4 reservoirs (5, 10, 15 and 20 gal.); and pumps (pressure balanced and high/low with flows to 28 gpm and pressures to 3500 psi).

HE Power Packs incorporating AC & DC Hydraulic Motors

Self-contained modular power systems in fully assembled or kit form; wide range of standard or high efficiency pumps, motors, switches, mounts, valves, and reservoirs. Custom options also available. Pressures to 4,000 psi (276 Bar). Flows from 0.20 to 7.0 GPM.

Hydraulic Motors

Available in the GC, W, G20, G25 and G30 Series in unidirectional and birotational configurations. Motors available with modular valve, bearing, seal and shaft options for maximum flexibility. Displacements from 0.065 to 9.82 cu. in. (1.06 to 161 cc) per revolution. Pressures to 4,000 psi (275 Bar).

Two-Stage Hydraulic Pumps

External gear pumps designed for high-speed positioning coupled with maximum working pressure. High-pressure displacements from 0.258 to 1.395 cu. in. (4.23 to 22.86 cc) per revolution. Pressures to 4,000 psi (275 Bar). Flows from 5 to 28 GPM.

Rotary Flow Dividers

Rotary-gear units up to four sections for synchronized operation of multiple cylinders or motors, proportional division of output or intensified flow. Single-section displacements from 0.065 to 0.813 cu. in. (1.0 to 13.32 cc) per revolution. Pressures to 4,500 psi (306 Bar).

Call us for more information

For application assistance or detailed literature on any Haldex product line, call us toll-free: 1-800-572-7867. Visit our web site: <http://www.hbus.haldex.com> E-mail us: sales@hbus.haldex.com





PRODUCT RANGE

He Power Packs

12/24/48 VDC 0.8 – 3.5 kW and
0.75 – 3 kW AC modular power
packs

Pressure Switches

5 - 350 bar, connecting/
disconnecting

He Classic Power Packs

12/24/48 VDC modular
powerpacks in weatherproof
boxes

W300 Hydraulic pumps

0.8 – 5.7 cc/section 230 bar

W600 Hydraulic pumps

4 – 12 cc/section 276 bar

WM600 Hydraulic motors

4 – 12 cc/section 276 bar

W900 Hydraulic pumps

5 – 31 cc/section 276 bar

WM900 Hydraulic motors

5 - 31 cc/section 276 bar

WQ900 The quiet pump

5 - 23 cc/section 230 bar

W1500 Hydraulic pumps

19 - 50 cc/section 276 bar

WM1500 Hydraulic motors

19 - 50 cc/section 276 bar

G25 Hydraulic pumps

23 – 87 cc/section 250 bar

GM25 Hydraulic motors

23 – 87 cc/section 250 bar

GPA Internal Gear pumps

1.7 – 63 cc/section 100 bar

GC Hydraulic pumps / fluid motors

1.06 – 11.65 cc/section 276 bar

II-Stage Hydraulic pumps

4.2 – 22.8 cc/section 276 bar

Rotary Flow Dividers

3.8 – 13.3 cc/section 300 bar

D Hydraulic pumps

3.8 - 22.9 cc/section 207 bar

G20/G30 Hydraulic pumps

23 – 161 cc/section 276 bar

GM20/GM30 Hydraulic motors

23 – 161 cc/section 276 bar

G20/G30 (LS) Hydraulic pumps

23 – 161 cc/section 276 bar

Transmission pumps

Fuel pumps

www.hbus.haldex.com



Haldex Hydraulics Corp.

2222 15th Street
ROCKFORD, IL 61104
USA
Tel: +1-815 398 4400
Fax: +1-815 398 5977
E-mail: sales@hbus.haldex.com

Haldex Hydraulics Corp.

214 James Farm Road
STATESVILLE, NC 28625
USA
Tel: +1-704 873 2587
Fax: +1-704 878 0530
E-mail: sales@hbus.haldex.com

Haldex Hydraulics AB

Box 95
SE-280 40 SK. FAGERHULT
Sweden
Tel: +46-433 32400
Fax: +46-433 30546
E-mail: sales@hbse.haldex.com

Haldex Hydraulics AB

Box 511
SE-195 25 MÄRSTA
Sweden
Tel: +46-8 591 288 50
Fax: +46-8 591 288 60
E-mail: sales@hbse.haldex.com

Haldex Hydraulics GmbH

Postfach 1507
D-95014 HOF
Germany
Tel: +49-9281 895-0
Fax: +49-9281 87133
E-mail: sales@hbde.haldex.com



Haldex is an innovator in vehicle technology supplying proprietary systems and components for trucks, cars and industrial vehicles, worldwide. With 4,100 employees and yearly sales exceeding 6 billion Swedish Kronor, Haldex is listed on the Stockholm Stock Exchange (www.haldex.com).