



Bray®

SERIES 20/21 Wafer/Lug
1"-12" (25mm -300mm)

BUTTERFLY VALVES
316 STAINLESS STEEL VALVE
FOR FOOD, BEVERAGE & CHEMICAL INDUSTRIES

1"-12" (25mm -300mm)

Bray Controls offers a new line of butterfly valves with two-piece 316 Stainless Steel bodies in wafer style and lug style.

1"-1½" valves are wafer bodies
 2"-12" valves are wafer and lug bodies
 1"-6" valves are investment cast bodies
 8"-12" valves are sand cast bodies
 This special line of valves has the specific advantage of a high integrity corrosion resistant exterior for use in aggressive environments.

DISC/STEM An important feature is the one-piece design. This design provides outstanding protection from the particle entrapment and bacterial growth. The thin disc profile allows a high flow capacity (Cv rating, up to 50% greater than most through -stem designs) and greater pressure recovery thus resulting in lower pressure drops and a more energy efficient valve. Disc/stems are offered as investment cast 316 Stainless Steel or fabricated 316 Stainless Steel.

FLANGE LOCATING HOLES
 Provide quick and proper alignment during installation, thus allowing the installer to center the valve in the pipeline between the flanges.

BRAY'S UNIQUE SEAT DESIGN is one of the valve's key elements. The resilient seat features a unique "tonque and groove" retention method which holds securely between either slip-on or weld-neck flanges and also allows simple and fast field replacement. This resilient seat features lower torque than many valves on the market today and provides complete isolation of flowing media from the body.

PRIMARY AND SECONDARY SEALS The Primary Seal is achieved by an interference fit of the molded seat flat with the disc hub. The Secondary Seal is an interference fit as a result of the stem diameter. These seals prevent line media from coming in contact with the stem or body.

ACTUATOR MOUNTING FLANGE AND STEM CONNECTION
 Designed for direct mounting of Bray power actuators and manual operators. This design meets ISO 5211. Extended neck allows easy access without interference with pipe flanges. No brackets or adapters are required.



FEATURES

A major design advantage of the Bray valve product line is international compatibility. These valves are compatible with most world flange standards – ANSI Class 125/150, BS 10 Table D and E, BS 4504 NP10/16, DIN ND 10/16, AS 2129 and JIS 10. In addition, the valves are designed to be able to comply with ISO 5752 face to face. Therefore, one valve design can be used in many different world markets. Bray's Series

20 valve is a wafer version with flange locating holes, and the Series 21 is the companion lug version for dead-end service and other flange requirements. All Bray valves are tested to 110% of full pressure rating before shipment.

STEM BUSHING is a non-corrosive, heavy duty acetal bushing which absorbs actuator side thrusts.

STEM SEAL The double "U" cup seal design is self-adjusting and gives positive sealing in both directions.

BODY BOLTS Standard material is 316 Stainless Steel.

VELOCITY LIMITS
For On/Off Services:

PRESSURE RATINGS

When valve is placed between flanges for b-directional bubble-tight shut off, disc in closed position:

Disc/Stems for Resilient Seated Valves

316 Stainless Steel and Hastelloy © C: 1"-12" (25mm-300mm) 150 psi (10 bar)

EPDM and Buna -N molded: 2"-12" (50mm-300mm) 150 psi (10 bar)

Disc/Stems for PTFE Seated Valves

316 Stainless Steel and Hastelloy © C: 2"-12" (50mm-300mm) 150 psi (10 bar)

PTFE molded: 2"-12" (50mm-300mm) 100 psi (7 bar)

For Dead-end Service Applications:

With *downstream flanges installed*, the dead-end pressure ratings are equal to

MATERIALS SELECTION

Body:

- 316 Stainless Steel per ASTM A351 Type CF8M
- 1"-6" Investment Cast 8"-12" Sand Cast

Seat:

- PTFE-Molded EPDM
- EPDM-Food Grade
- White Buna-N – Food Grade
- Chlorobutyl – Food Grade
- FKM*
- Buna-N Food Grade

DISC/STEM

- 316 Stainless Steel per ASTM A351 Type CF8M
- Hastelloy© C-22 per ASTM b494 Type CX2MW
- EPDM molded over 17-4 Stainless Steel per ASTM A747 Type CB7Cu-1 Heat Treated
- Buna-N molded over 17-4 ph Stainless Steel per ASTM A747 Type CB7Cu-1 Heat Treated
- PTFE molded over 17-4 ph Stainless Steel per ASTM A747 Type CB7Cu-1 Heat Treated
- Halar© molded over 17-4 ph Stainless Steel per ASTM A747 Type CB7Cu-1 Heat Treated

*FKM is the ASTM D1418 designation for Fluorinated Hydrocarbon Elastomers (also called Fluoroelastomers).
Hastelloy © is a registered trademark of Haynes International, Inc.
Halar © is a registered trademark of Ausimont U.S.A., Inc.

Cv VALUES - VALVE SIZING COEFFICIENT

Valve-Size	Disc Position (Degrees)										
	ins	mm	90°	80°	70°	60°	50°	40°	30°	20°	10°
1	25	61	56	36	21	11	5.6	2.7	.97	.07	
1 1/2	40	147	129	87	50	26	12.8	5.9	1.7	.25	
2	50	244	172	123	73	45	27	16	7	.89	
2 1/2	65	439	310	201	115	71	43	25	11	1.4	
3	80	691	488	290	165	102	62	35	16	2.01	
4	100	1282	906	515	294	182	110	63	28	3.57	
5	125	2070	1416	805	459	284	172	98	44	6	
6	150	2786	1873	1065	607	376	227	130	59	7	
8	200	5191	3402	1935	1147	714	427	244	106	13	
10	250	8238	5385	3062	1815	1130	675	387	168	21	
12	300	12102	7820	4448	2636	1642	981	562	245	31	

TEMPERATURE RANGE OF SEATS

TYPE	Max.	Min
EPDM	+250°F (121°C)	-40°F (-40°C)
Buna-N	+212°F (100°C)	0°F (-18°C)
FKM*	+400°F (204°C)	0°F (-18°C)
PTFE-Lined EPDM	+250°F (121°C)	-20°F (-29°C)

See Chart for Actuator Mounting Flange Drilling.

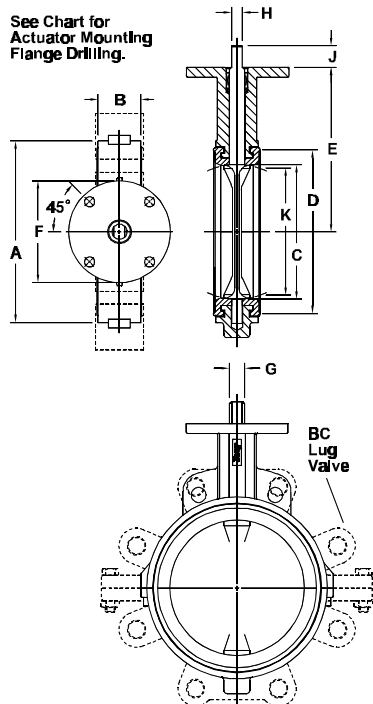

DIMEN- SERIES 20 Wafer

Valve Size		Mtg Flange Drilling												
ins	mm	A	B	C	D	E	F	BC	No. Holes	Hole Dia.	G	H	J	K
1	25	2.36	1.1	1.25	1.73	3.54	2.56	1.97	4	.28	.39	.32	1.00	.44
1 1/2	40	3.15	1.2	1.84	2.53	4.12	2.56	1.97	4	.28	.39	.32	1.00	1.35
2	50	3.69	1.6	2.00	2.84	5.50	3.54	2.76	4	.39	.55	.39	1.25	1.32
2 1/2	65	4.19	1.7	2.50	3.34	6.00	3.54	2.76	4	.39	.55	.39	1.25	1.91
3	80	4.88	1.7	3.00	4.03	6.25	3.54	2.76	4	.39	.55	.39	1.25	2.55
4	100	6.06	2.0	4.00	5.16	7.00	3.54	2.76	4	.39	.63	.43	1.25	3.57
5	125	7.12	2.1	5.00	6.16	7.50	3.54	2.76	4	.39	.75	.51	1.25	4.63
6	150	8.12	2.1	5.75	7.02	8.00	3.54	2.76	4	.39	.75	.51	1.25	5.45
8	200	10.50	2.5	7.75	9.47	9.50	5.91	4.92	4	.57	.87	.63	1.25	7.45
10	250	12.75	2.5	9.75	11.47	10.75	5.91	4.92	4	.57	1.18	.87	2.00	9.53
12	300	14.88	3.0	11.75	13.47	12.25	5.91	4.92	4	.57	1.18	.87	2.00	11.47

SERIES 21 Lug

Lug Bolting Data		
BC	No. Holes	Thrd s
-	-	-
-	-	-
4.75	4	5/8-11
5.50	4	5/8-11
6.00	4	5/8-11
7.50	8	5/8-11
8.50	8	3/4-10
9.50	8	3/4-10
11.75	8	3/4-10
14.25	12	7/8-9
17.00	12	7/8-9