



Torqaxis™

Two Speed Hydraulic Motor

SM Series Service Procedure

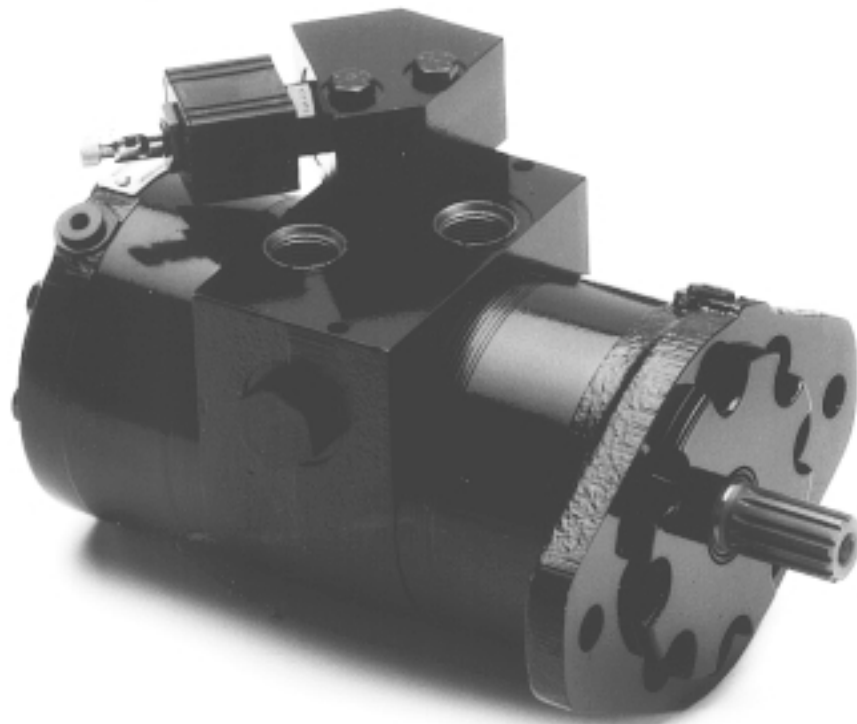

Table of Contents

	Page
Section 1 General Information	
Definitions	3
Introduction	3
Troubleshooting Guide	4
Troubleshooting Check List	5
Tools and Material Required for Servicing	6
Service Parts List Chart	7
Exploded Assembly View	8-10
Section 2 Repair	
Disassembly & Inspection	11-16
Assembly	17-22
Solenoid Assembly	23
Final Checks	24
Section 3 Maintenance	
Hydraulic Fluids	24
Filtration, Operating Temperature	24
Tips for Maintaining the system	25



WARNING

FAILURE OR IMPROPER SELECTION OR IMPROPER USE OF THE PRODUCTS AND/OR SYSTEMS DESCRIBED HEREIN OR RELATED ITEMS CAN CAUSE DEATH, PERSONAL INJURY, AND PROPERTY DAMAGE.

This document and other information from the company, its subsidiaries and authorized distributors provide product and/or system options for further investigation by users having technical expertise. It is important that you analyze all aspects of your application and review the information concerning the product or system in the current product catalog. Due to the variety of operating conditions and applications for these products or systems, the user, through its own analysis and testing, is solely responsible for making the final selection of the products and systems and assuring that all performance, safety and warning requirements of the application are met.

The products described herein, including without limitation, product features, specifications, designs, availability, and pricing are subject to change by the company and its subsidiaries at any time without notice.

Introduction

Service Manual for Series SM Two Speed High Torque Motor

This service manual has one purpose: to guide you in maintaining, troubleshooting, and servicing the SM Two Speed High Torque Motor. These motors provide long life while operating with low radial side loads.

Read the trouble shooting information to eliminate non-hydraulic causes and hydraulic system problems. The check list identifies hydraulic system and possible motor component problems.

The two column format of the Disassembly and Inspection, and Assembly sections make it easier to conduct major work on the motor. Column one explains the procedure in detail. Column two illustrates this procedure with photographs. Read all material carefully and pay special attention to the notes, cautions, and warnings.

The component part names and item numbers assigned on the exploded assembly views corresponds with names and item numbers (in parentheses) used in the disassembly and assembly procedures.

Service part number charts display exploded view item numbers and part numbers.

Obtain service parts from the Original Equipment Manufacturer or Ross Operations Distributor.

We welcome suggestions to make this manual clearer or more complete. If you are stuck, contact Ross. Don't second guess the manual. Following this safe and productive procedure results in restoring the reliable long-life operation engineered into the motor.

Definitions

WARNING:  **A WARNING REFERS TO PROCEDURES THAT MUST BE FOLLOWED FOR THE SAFETY OF THE EQUIPMENT OPERATOR AND THE PERSON INSPECTING OR REPAIRING THE MOTOR.**

CAUTION:  **A CAUTION refers to a mandatory procedure which avoids damage to the motor or other system components.**

NOTE: **A NOTE provides key information to make a procedure easier or quicker to complete.**

Troubleshooting Guide

NOTE: Before troubleshooting any system problem, check service literature published by the equipment and/or component manufacturers. Follow their instructions, if given, for checking any component other than the motor unit.

Preparation

Make your troubleshooting easier by preparing as follows:

- Work in a clean, well lighted area.
- Have proper tools and materials nearby.
- Have an adequate supply of clean petroleum - based solvent.
- Prior to any motor disassembly, plug the open ports and case drain.
- Clean all dirt from the outside of the motor.
- Prior to assembly lightly oil all seals, rollers, rolls and the threaded bolt ends.

**WARNING: SINCE SOLVENTS ARE FLAMMABLE, BE EXTREMELY CAREFUL WHEN USING ANY SOLVENT, EVEN A SMALL EXPLOSION OR FIRE COULD CAUSE INJURY OR DEATH.**

**WARNING: WEAR EYE PROTECTION AND COMPLY WITH OSHA AND OTHER MAXIMUM AIR PRESSURE REQUIREMENTS.**

Preliminary Checks

Hydraulic systems are often trouble free. Therefore check the following easy to check items first, such as:

- Parts damaged from impact that were not properly repaired, or that should have been replaced.
- Improper replacement parts used in previous servicing.
- Mechanical linkage problems such as binding, broken parts or chain , loose parts, or slipping belts.

Hydraulic Components

If the motor has low speed or torque, look at the check list on the next page first. Since these motors maintain volumetric and torque efficiencies during their useful life, the problem is usually elsewhere in the hydraulic system.

However, there are hydraulic system problems which can drastically reduce the long life designed into these motors. Three key areas to check are:

- Temperature: Do not exceed 180°F.
- Fluid: Viscosity at the maximum temperature must exceed 50 ssu.
- Filtration: A Beta 25 ratio of at least 2.

Troubleshooting Checklist

Trouble	Cause	Remedy
Oil leakage	1. Hose fittings loose, worn, or damaged.	Check & replace damaged "O" Rings. Torque to manufacturers specifications.
	2. Motor section seal rings (7) deteriorated by excess heat.	Replace oil seal rings. Correct heat problem.
	3. Tie bolt loose.	If bolts are loose because of excessive pressures as indicated by most or all being loose replace bolts & advise customer to correct the pressure regulation.
	4. Broken tie bolts.	Replace bolts.
	5. Internal shaft seal worn or damaged	Replace seal.
	6. Worn shaft and internal seal.	Replace shaft and seal.
Significant loss of speed under load	1. Lack of sufficient oil supply.	(a) Check for faulty relief valve and adjust or replace as required. (b) Check for and repair worn pump. (c) Check for and use correct oil for temperature of operation. Check reservoir fluid level.
	2. High internal motor leakage.	Replace worn IGR™ set.
	3. Excessive heat.	Locate excessive heat source (usually a restriction or lack of an oil cooler) in the system and correct the condition.
Low mechanical efficiency or undue high pressure required to operate motor	1. Line blockage	Locate blockage source and repair or replace.
	2. Internal interference	Disassemble motor, identify and remedy cause.
	3. Excessive binding or loading in system external to motor unit.	Locate source and eliminate cause.
Lack of pressure	1. Low flow output of pump	Repair or replace worn pump.
	2. Relief valve set incorrectly or not closing completely.	Reset relief, look for contamination, or replace.

CAUTION: Seals in the system will shrink, harden or crack if fluid temperatures exceed 180°F (82.2°C), resulting in loss of ability to seal.



Tools and Materials Required to Service the SM Series

- Clean, petroleum-based solvent
- Emery paper
- Vise with soft jaws
- Air pressure source
- Screwdriver
- Tape
- Breaker bar or impact wrench
- Torque wrench 50 ft. lbs
- Socket 1/2 inch
- 1/4 inch Allen wrench
- Adjustable crescent wrench or hose fitting wrenches

SM Service Parts List Chart

SERIES	EXPLODED VIEW							
	ITEM #	3	5	7	8	14	21	20
SM	DESCRIPTION	O-RING	CLIP	COMMUTATOR PLATE	CHECK BALL	BEARING	SEAL HIGH PRESSURE	SEAL DUST
	Service Part #	1046	1660	3190	1021	1156	2332	1141

SERIES	EXPLODED VIEW						
	ITEM #	12	13	15	16	25	19
SM	DESCRIPTION	PLUG, SPOOL PORT	SPRING	CHECK BALLS SOLENOID BLOCK	O-RING SOLENOID	SOLENOID BLOCK	HEX BOLT
	Service Part #	75013-10	1826	1320	032841	1823	021442

DISPLACEMENT GROUP	EXPLODED VIEW				
	ITEM #	6	1	4	17
	DESCRIPTION	SHAFT STANDARD	HEX BOLT	IGR SET REAR	IGR SET FRONT
07	Service Part #	2216-072	021363	2904-1	2917-1
11	Service Part #	2216-108	021428	2904-2	2917-2
14	Service Part #	2216-142	021356	2904-3	2917-3
18	Service Part #	2216-176	021306	2904-4	2917-4
21	Service Part #	2216-212	021382	2904-5	2917-5
26	Service Part #	2216-258	021437	2904-6	2917-6

HOUSING GROUP	EXPLODED VIEW		
	ITEM #	9	10
	DESCRIPTION	CENTER BLOCK	FRONT BEARING HOUSING/FLANGE
	Service Part #	PA-2534 (7/8-14 O-ring, Pilot Act.)	PA-2532-2 (1/4-19 BSPP)
	Service Part #	PA-2535 (7/8-14 O-ring Solenoid)	PA-2532-1 (7/16-20 O-Ring)
	Service Part #	PA-3106 (BSPP Pilot Act.)	
	Service Part #	PA-3111 (BSPP Solenoid)	
	Service Part #	PA-2817 (Manifold, Pilot Act.)	

OPTION GROUP	EXPLODED VIEW			
	ITEM #	2	18	11
	DESCRIPTION	COVER	SOLENOID	VALVE
	Service Part #	M110C-6 Standard	1824 with Manual Override 2891 without Manual Override	1825 Open Center 2792 Closed Center

SEAL KIT, COMPLETE	KIT # SK000137			
	Includes;	P/N	QTY	Description
		1046	6	Body O-rings
		1141	1	Dust Seal
		2332	1	High Pressure Seal
		032841	5	Solenoid Block O-Rings
		1156	1	Bearing



SM Exploded View - Typical Flange End

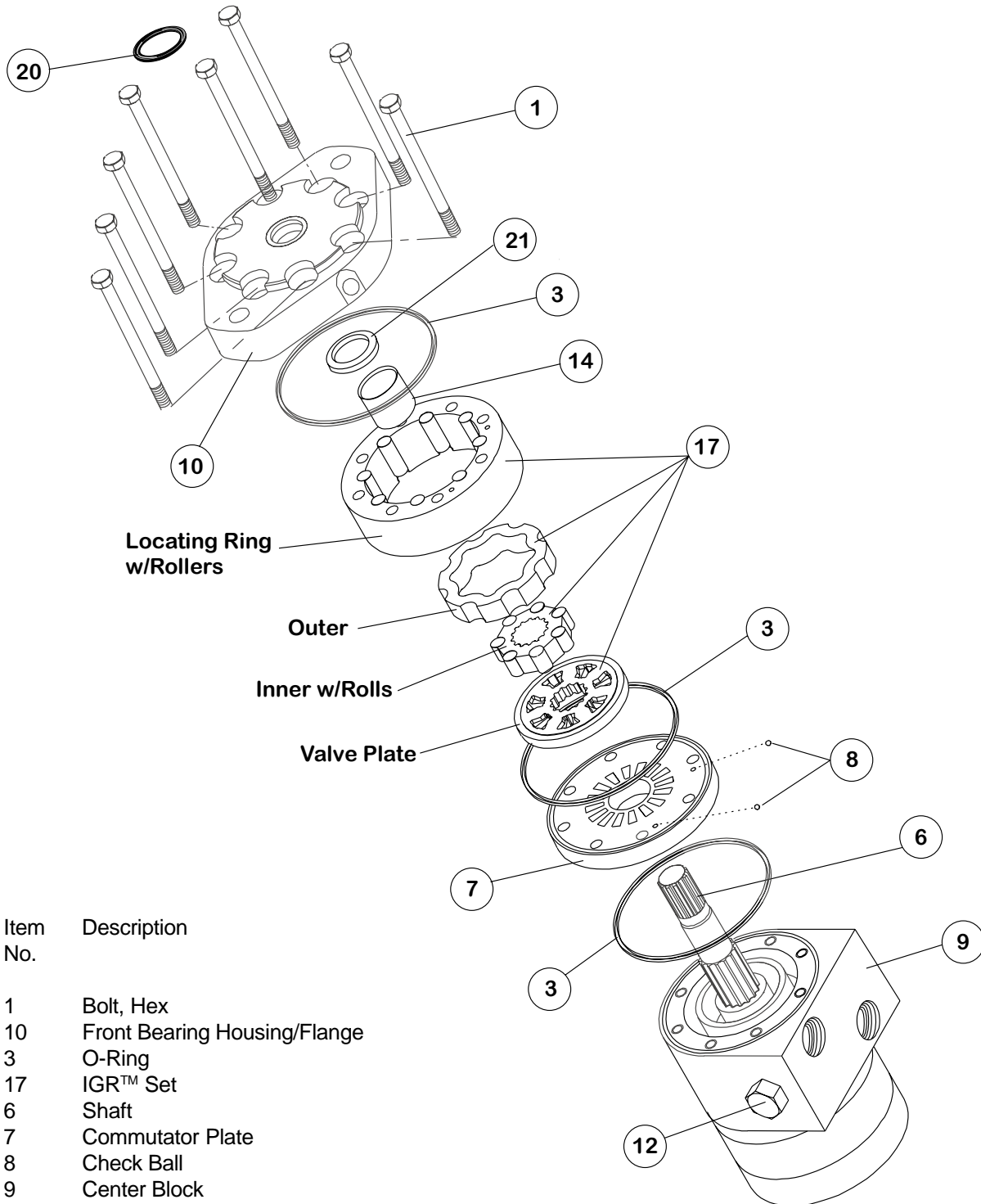

Item No.	Description
1	Bolt, Hex
10	Front Bearing Housing/Flange
3	O-Ring
17	IGR™ Set
6	Shaft
7	Commutator Plate
8	Check Ball
9	Center Block
12	Plug, Spool Port
20	Seal, Dust
21	Seal, High Pressure
14	Bearing

SM Exploded View - Typical Cover End

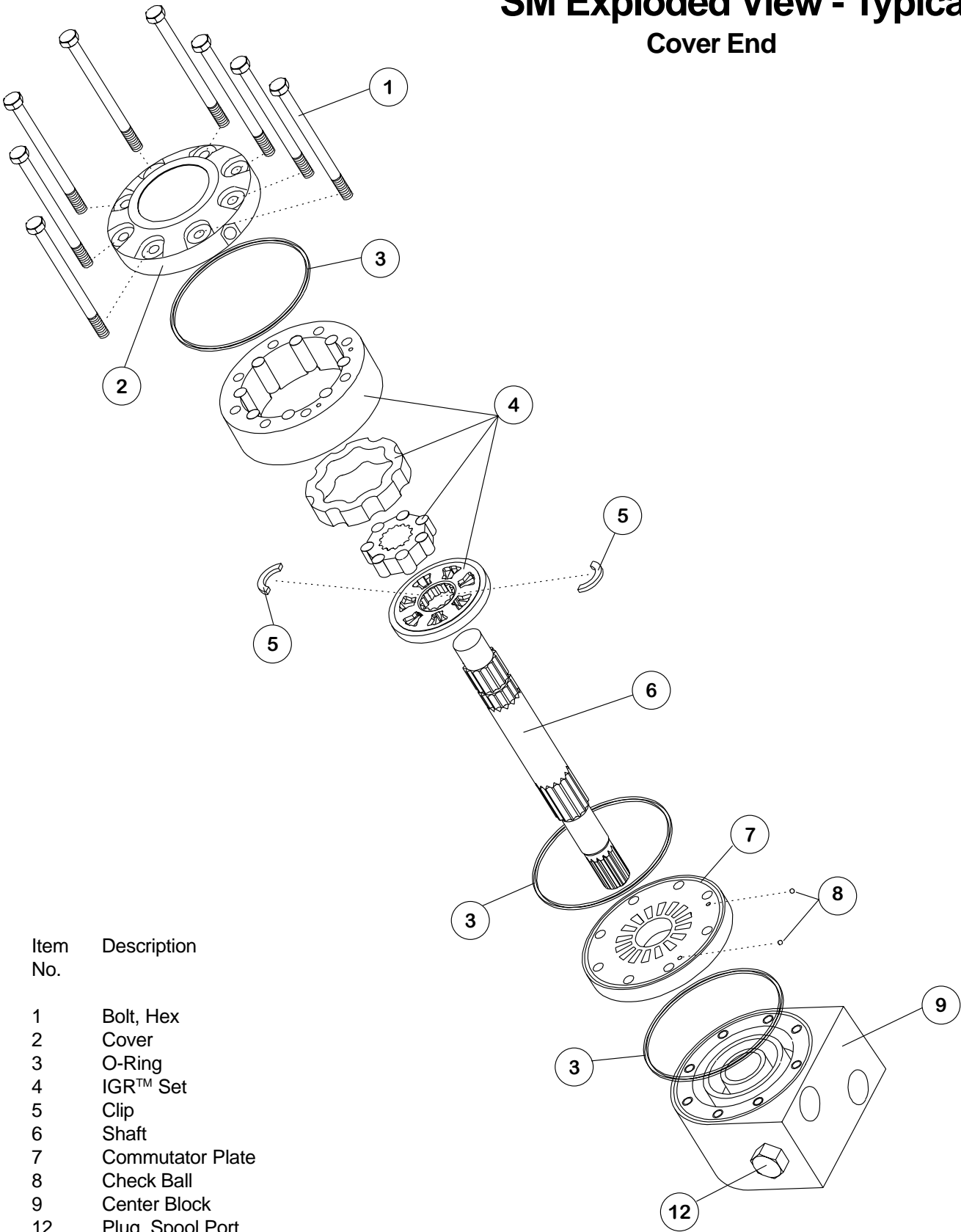

Item No.	Description
1	Bolt, Hex
2	Cover
3	O-Ring
4	IGR™ Set
5	Clip
6	Shaft
7	Commutator Plate
8	Check Ball
9	Center Block
12	Plug, Spool Port



SM Exploded View - Typical Optional Solenoid

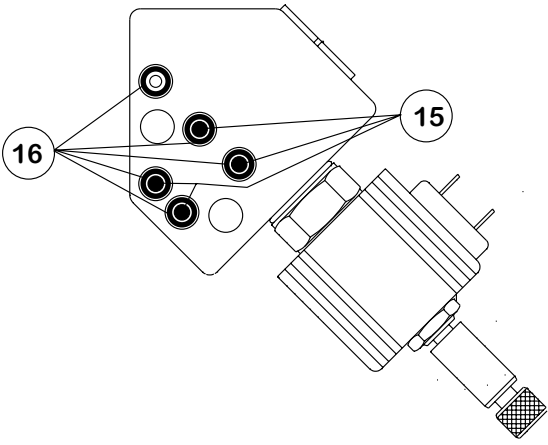
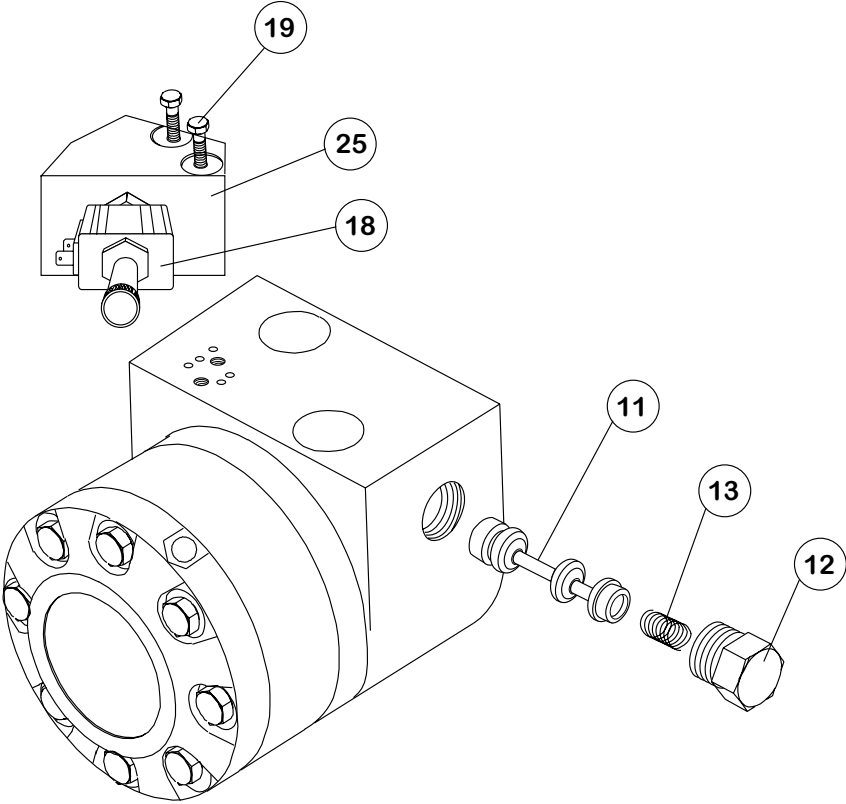

Solenoid Block
Bottom View

Item No.	Description
12	Plug, Spool Port
13	Spring, Valve
11	Valve
15	Check Ball, Solenoid Block
16	O-Ring Solenoid
25	Solenoid Block
18	Solenoid
19	Hex Bolt



Disassembly and Inspection

(Preparation Before Disassembly)

- Before you disassemble the motor unit or any of its components read this entire manual. It provides important information on parts and procedures you will need to know to service the motor.
- Refer to page four for tools and other items required to service the motor and have them available.
- Thoroughly clean off all outside dirt, especially from around fittings and hose connections, before disconnecting and removing the motor. Remove rust or corrosion from coupling shaft.
- Remove coupling shaft connections and hose fittings and immediately plug port holes and fluid lines.
- Remove the motor from system, drain it of fluid and take it to a clean work surface.
- Clean and dry the motor before you start to disassemble the unit.
- As you disassemble the motor clean all parts, except seals, in clean petroleum based solvent, and blow them dry.

WARNING: SINCE THEY ARE FLAMMABLE, BE EXTREMELY CAREFUL WHEN USING AND SOLVENT. EVEN A SMALL EXPLOSION OR FIRE COULD CAUSE INJURY OR DEATH.



WARNING: WEAR EYE PROTECTION AND BE SURE TO COMPLY WITH OSHA OR OTHER MAXIMUM AIR PRESSURE REQUIREMENTS.



CAUTION: Never steam or high pressure wash hydraulic components. Do not force or abuse closely fitted parts.



- Keep parts separate to avoid nicks and burrs.
- Discard all seals and seal rings, as they are removed from the motor. Replace all seals, seal rings and any damaged or worn parts with genuine Ross or OEM approved service parts.

Disassembly and Inspection (Reference Exploded Assembly View)

1. Mount the motor in a soft jawed vice, shaft up, clamping on the cover assembly. Remove manifold port o-rings if applicable. SEE FIGURE D1

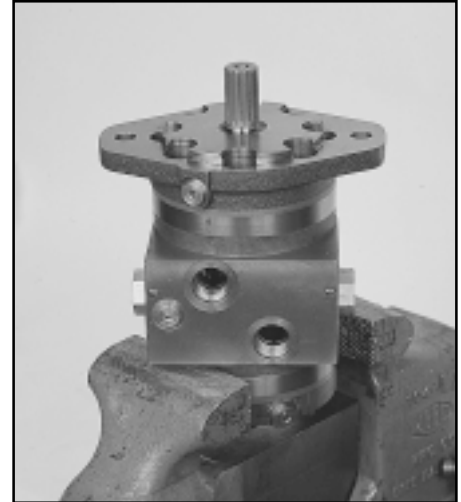

Figure D1

SEE FIGURES D3.

2. Remove the 8 5/16-24 bolts (1) SEE FIGURES D2.

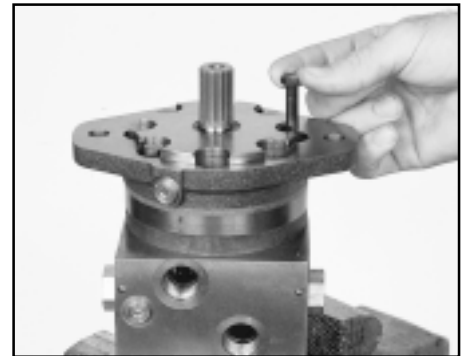

Figure D2

3. Lift front bearing housing/flange (10) by lightly tapping the flange up off the dowels with a soft hammer. Do not remove the dowel pins., SEE FIGURES D3.

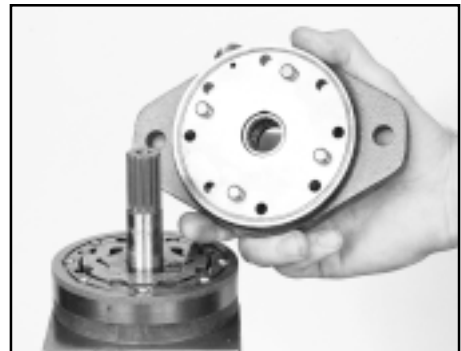

Figure D3

4. Remove the locating ring carefully to prevent rollers from falling or remove rollers with a magnet. SEE FIGURE D4.

Caution: The rollers & check balls will fall out so be ready to catch them to prevent damage and loss.



Note: The check balls may fall into the bolt holes or into the commutator ports.

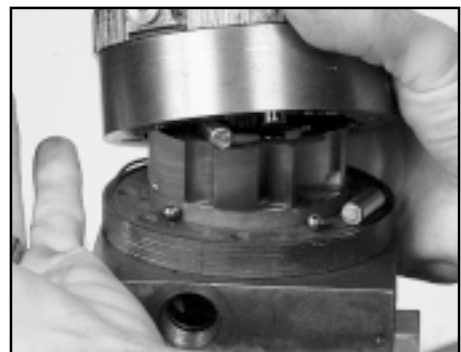

Figure D4

5. Remove outer, rolls, inner and valve plate. SEE FIGURES D5, D6, D7.

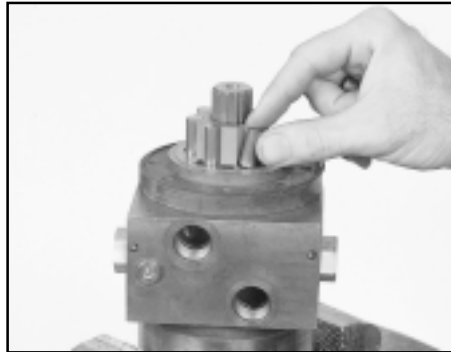

Figure D6



Figure D5

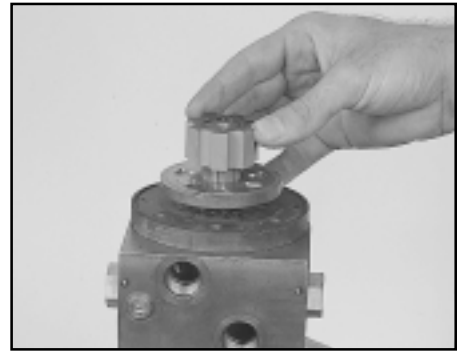

Figure D7

6. Remove commutator plate assembly (7) and seal (3). SEE FIGURE D8.



Figure D8

7. Turn motor assembly upside down and clamp center block (9) in vise. SEE FIGURE D9.

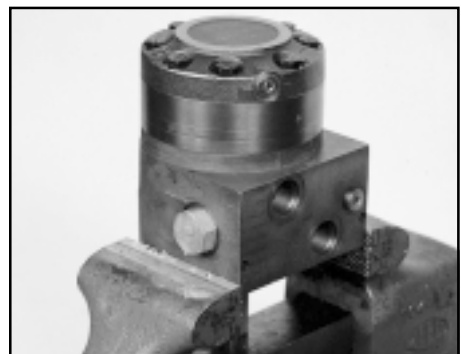

Figure D9

- Loosen and remove the 8 5/16-24 bolts (1), remove the cover (2), locating ring, check valve balls (quantity 2) (8) and rollers. SEE FIGURES D10 & D11.

CAUTION: The rollers will fall out so be ready to catch them to prevent damage and loss.



Figure D10

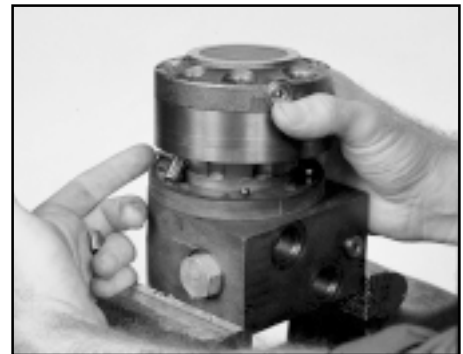

Figure D11

- Remove the outer, rolls, inner and valve plate. SEE FIGURE D12.

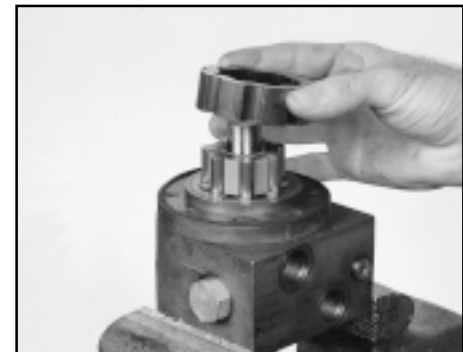

Figure D12

- Lift shaft (6) up a short distance, push the valve plate down and remove the 2 snap ring halves (5). SEE FIGURE D13.

Note: With the snap ring removed the shaft will fall out of the motor unless, you maintain a grip on the it.



Figure D13

11. Remove the valve plate. Lift and remove shaft (6). SEE FIGURE D14.
12. Remove commutator plate (7) and seal (3).
13. If the locating ring and front bearing housing (10) or the end cover (2), it can be separated by holding the locating ring by hand and tapping the cover with a soft nose hammer.

Caution: If placed in a vise, use minimal clamping force to prevent a permanent out of round condition.



Figure D14

SEAL REMOVAL

(700 Series Flange shown for illustration purpose only)

14. Remove dust seal (20) by leveraging it outward.
15. To remove the high pressure lip seal, the roller bearing must first be removed. Use a suitable bearing puller while taking care not to damage the flange. Once the bearing is removed, the seal can be pushed out of the flange using a blunt instrument. SEE FIGURE D15.

Caution: Do not scratch the flange seal area that would possibly create a leak path.

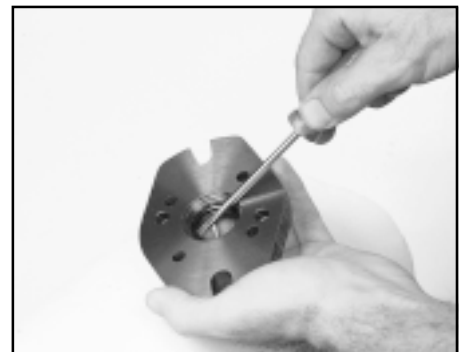

Figure D15

Pilot Option:

To change pilot from normally parallel to normally series or vice versa. Also valid for solenoid shift motors.

1. Remove the plugs (12) on the center block (9).
SEE FIGURE D16.
2. Remove the spool (11) and spring(13). SEE FIGURE D17.
3. Looking at the port surface, install the spool with ...
 - A) the “double” or "wide" land nearest the “pilot port” for **normally parallel** operation. SEE FIGURE D18.
 - B) the “double” or "wide" land opposite the “pilot port” for **normally series** operation. SEE FIGURE D19.
4. The spring is always located on the side, opposite the “pilot port”.
SEE FIGURE A23.

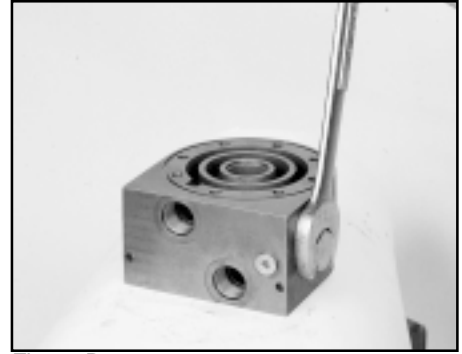

Figure D16

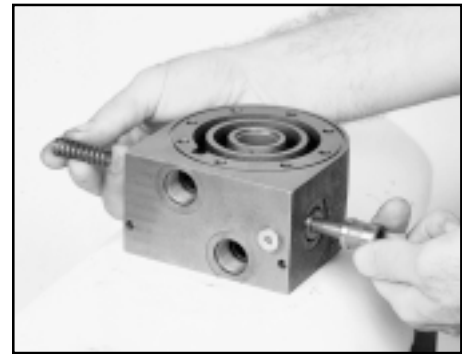

Figure D17

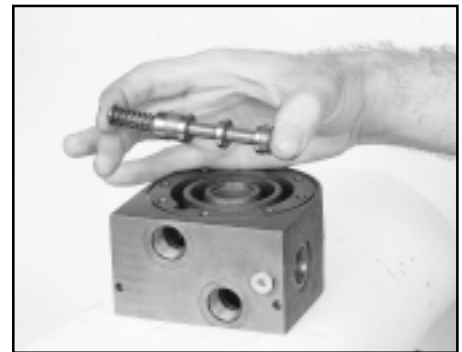

Figure D18



Figure D19

THE DISASSEMBLY OF THE MOTOR IS COMPLETED.

PARTS INSPECTION:

Inspect the shaft for a smooth polish in the bearing and seal areas.

If scratched, polish with fine emery paper in circumferential direction. If pitted, or if scratches are deep, replace shaft and check the rest of the motor for scratches, galling, or contamination damage. Replace parts as needed.

If your motor has a thru shaft option and the seals were leaking, the entire cover must be replaced. Thru covers contain no servicable parts.

MOTOR ASSEMBLY

Replace all seals and seal rings with new ones each time you reassemble the motor unit. Lubricate all seals and seal rings with oil or clean grease before assembly.

NOTE: Individual seals and seal rings as well as a complete seal kit are available. The parts should be available through most OEM parts distributors or Parker distributors. (Contact your local dealer for availability.)

NOTE: Unless otherwise indicated, do not oil or grease parts before assembly.

Wash all parts in clean petroleum-based solvents before assembly. Blow them dry with compressed air. Remove any paint chips from mating surfaces and from port and sealing areas.

WARNING: SINCE THEY ARE FLAMMABLE, BE EXTREMELY CAREFUL WHEN USING ANY SOLVENT. EVEN A SMALL EXPLOSION OR FIRE COULD CAUSE INJURY OR DEATH.



WARNING: WEAR EYE PROTECTION AND BE SURE TO COMPLY WITH OSHA OR OTHER MAXIMUM AIR PRESSURE REQUIREMENTS.



Procedure:

1. Before assembling the flange seals and bearing, visually inspect the flange bores for deep scratches, raised material or sharp edges that would interfere with assembly or cause leaks.
2. Using a suitable installation tool, press the high pressure lip seal (21) into the seal bore (the longer, internal bore) and bottom it against the shoulder. The seal must be installed with the inside lip pointing towards the inside of the motor. Using an arbor press and suitable bearing installation tool, the bearing (14) can then be pressed in after the seal .065" to .085" below the face of the flange.

3. Install the dust seal (20) using a suitable seal driver in the outside seal bore of the flange. The dust seal should be installed with the inside lip facing away from the flange and flush with the flange face.

4. Position the center block so the pilot port or solenoid ports are on your right and lock in the vise. SEE FIGURE A01.

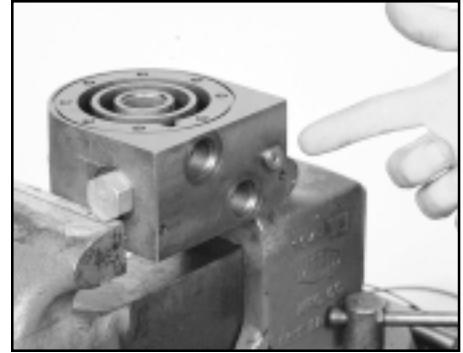

Figure A01

5. Place the o-ring (3) in center block seal gland. SEE FIGURE A02.

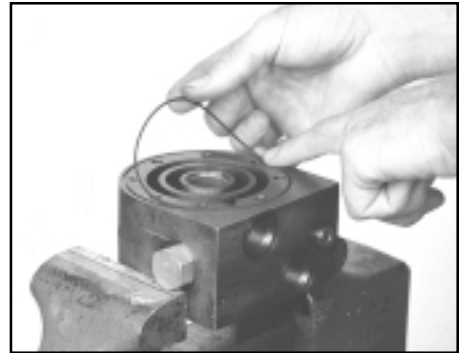

Figure A02

6. Place commutator plate (7) on the center block (9) with the square ring groove facing up. Align the 8 bolt holes in the plate with the 8 tapped holes in the body. (The holes will align in only 1 position). **Note:** Do not dislodge square ring seal (3) while positioning the commutator plate (7). SEE FIGURE A03

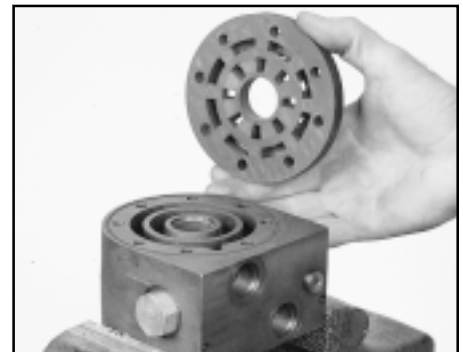

Figure A03

7. Insert the internal shaft through the commutator plate and center block with the spline snap ring groove "up". SEE FIGURE A04 Then place the counterbored (at the splines) valve plate on the shaft with the 7 port windows sharp edge facing the commutator plate. SEE FIGURE A05 Next put both snap ring halves (5) into the snap ring groove on the shaft (6). Hold the snap rings in place with pliers while gently tapping the shaft down, seating the snap rings into the counterbore. SEE FIGURE A05



Figure A04



Figure A05

7. Place the square cut seal (3) in the commutator plate (7) seal gland. SEE FIGURE A06.



Figure A06

8. Place the inner counterbored side down on the splines so that the semi-circular roll pockets are between the rotary valve port windows. SEE FIGURE A07.

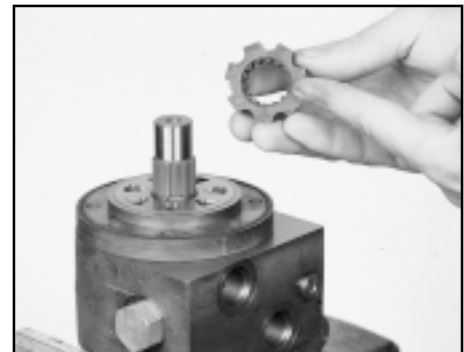

Figure A07

9. Place the outer over the inner and insert the rolls. The rolls should not block the ports in the valve plate. Place the check balls on their seats on the commutator plate. Assembly grease can be used to keep the check balls in place during assembly. SEE FIGURE A08.



Figure A08

10. Place the locating ring over the inner with the square ring groove up and the check ball counterbores over the check balls. Align the 8 bolt holes with the commutator holes. SEE Figure A09.
11. Alternate inserting long and short rollers between the outer and locating ring to match up with 4 dowels in the cover (2).

NOTE: The difference between rolls and rollers is that rolls have square ends and rollers have a radius on the end.



Figure A09

12. Place o-ring (3) in cover (2) seal groove. Assembly grease can be used to hold the o-ring in place during assembly. SEE FIGURE A10.

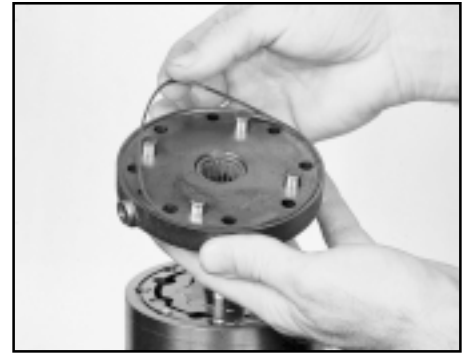

Figure A10

13. Place the cover (2) so the port markings (**IN**) (**IN**) are lined up with the corresponding ports. Also check the square ring seal (3) to verify that it hasn't dropped out. SEE FIGURE A11.



Figure A11

14. Install lubricated bolts (1) and torque diagonally to 15 ft lbs.
 - A. Increase torque diagonally 5 foot lbs on each bolt.
 - B. Rotate the shaft by hand through several rotations.
 - C. Repeat steps A & B until torque is 30 foot lbs.

SEE FIGURE A12

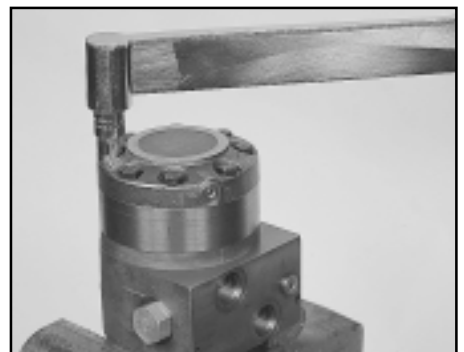

Figure A12

15. Turn motor right side up in the vice and install the square cut seal (3) in the center block seal gland. SEE FIGURE A13.

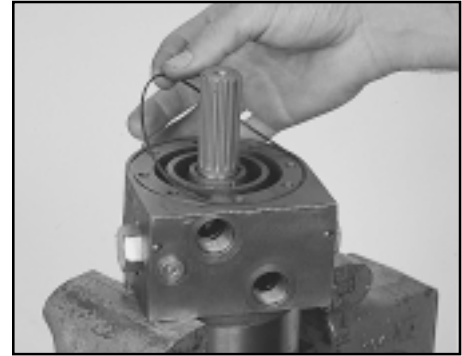

Figure A13

16. Place the commutator plate on the center block with the square ring groove facing up. Align the 8 bolt holes with the 8 tapped holes in the center block. SEE FIGURE A14

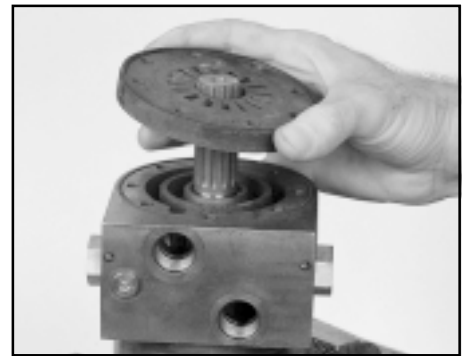

Figure A14

17. Place the valve plate, with the seven port window's sharp edge facing the commutator plate, over the splines of the shaft. The plate should be positioned one tooth off the opposite end valve plate when viewing valve plate port timing with respect to the commutator plate. SEE FIGURE A15.

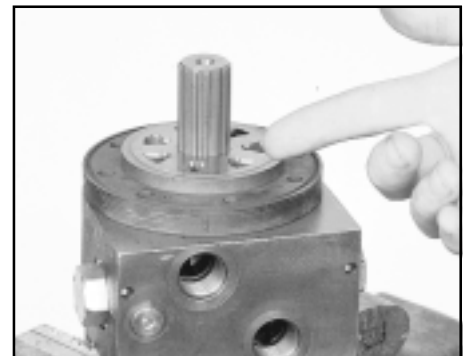

Figure A15

20. Install a o-ring into the grove in the commutator plate (7) then place the check balls (8) on their seats on the commutator plate. Assembly grease can be used to hold the check balls in place during assembly. SEE FIGURE A16

WARNING: DO NOT ROTATE THE LOCATING RING OR CHECK BALLS WILL DROP INTO BOLT HOLES.

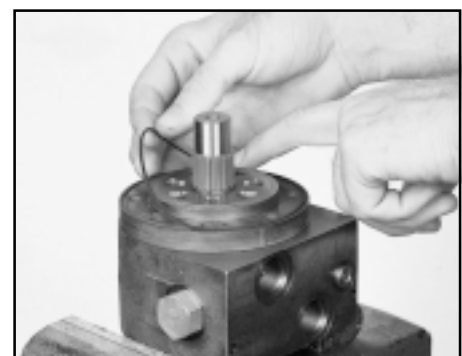

Figure A16

18. Place the inner over the splines of the shaft. Position the inner so the semi-circular roll pockets are between the rotary valve port windows. SEE FIGURE A17.
19. Place the outer over the inner and insert the rolls into the inner pockets.

NOTE: The difference between rolls and rollers is that rolls have square ends and rollers have a radius on the ends.

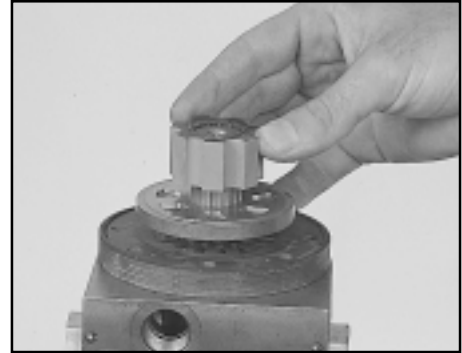

Figure A17

21. Place the locating ring section onto the commutator plate with the check ball counterbored facing downward over the balls. Align the 8 bolt holes with the commutator holes. Place the rollers in position alternating long and short to match up with the 4 dowels in the front bearing housing/flange (10). SEE FIGURE A18



Figure A18

22. Install a square ring seal (3) into the groove of the front bearing housing/flange (10). Place the front bearing housing w/ square ring over the shaft and onto the locating ring. Be sure to align the 4 dowels with the short dowels inside the locating ring and to align the bolt holes with the holes in the locating ring. (bolt hole pattern will only match one way.) SEE FIGURE A19

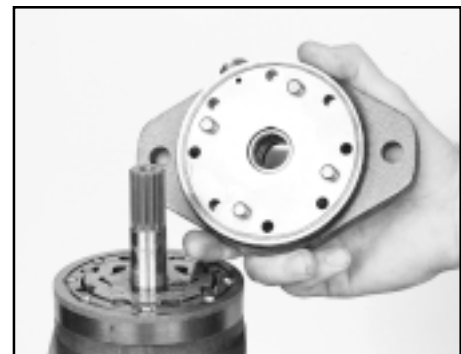

Figure A19

21. Install the 8 lubricated bolts and torque diagonally to 15 ft lbs.
 - A. Increase torque diagonally 5 foot lbs on each bolt.
 - B. Rotate the shaft by hand through several rotations.
 - C. Repeat steps A & B until torque is 30 foot lbs.

SEE FIGURE A20



Figure A20

Instructions for solenoid assembly

1. Place 4 check balls on their seats on the center block (15) SEE FIGURE A21

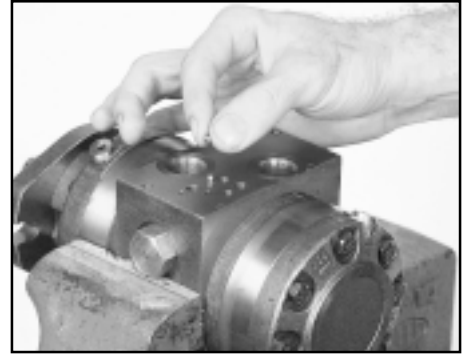

Figure A21

2. Place 5 O-rings (16) in the grooves on the solenoid block (17). SEE FIGURE A22

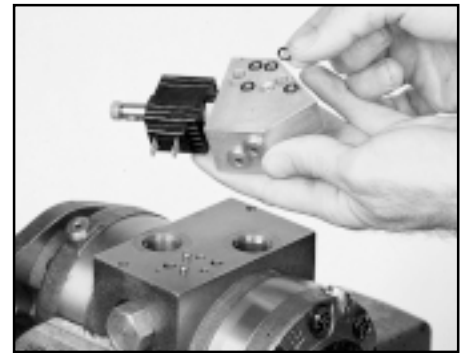

Figure A22

3. Place solenoid valve assembly on the center block, insert bolts and torque to 15 ft lbs. SEE FIGURE A23

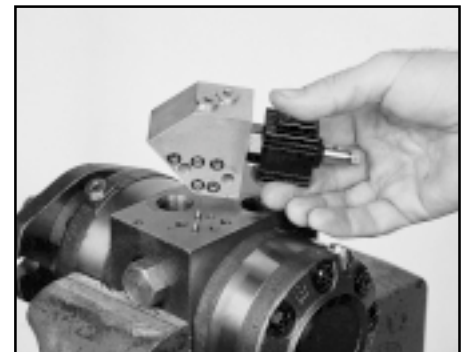

Figure A23

THE ASSEMBLY OF THE MOTOR IS NOW COMPLETE EXCEPT FOR KEYS, NUTS, ETC. AT INSTALLATION IF APPLICABLE. SEE FINAL CHECKS.

Final checks

- Pressurize the motor with 100 p.s.i. dry air or nitrogen and submerge in solvent to check for external leaks.
- Port with **IN** cast under it on housing (18) indicates shaft rotation.
- Check operation of the motor with a test stand.

Hydraulic Fluid

Keep the hydraulic system filled with one of the following:

- Hydraulic fluid as recommended by equipment manufacturer, with viscosity no less than 50 SSU.



CAUTION: Do not mix oil types. Any mixture, or a non approved oil, could deteriorate the seals. Maintain the proper fluid level in the reservoir. When changing fluid, completely drain old oil from the system. It is suggested also that you flush the system with clean oil, especially if there was a major hydraulic component failure. In addition run the system with no load for a period of time to allow the filters to clean up the oil. Then change the filters before returning the machine to service.

Filtration

- Recommended filtration: Beta 25 ratio of at least 2.

Oil Temperature

- Maximum operating temperature 180°

Tips for Maintaining the IGR™ Motor Hydraulic System

- Adjust fluid level in reservoir as necessary.
- Encourage all operators to report any malfunction or accident that may have damaged the hydraulic system or component.
- Do not attempt to weld any broken motor component. Replace the component with original equipment only.
- Do not cold straighten, or bend any motor part.
- Prevent dirt or other foreign matter from entering the hydraulic system. Clean the area around the filler caps before checking oil level.
- Investigate and correct any external leak in the hydraulic system, no matter how minor.
- Comply with manufacturer's specifications for cleaning or replacing the filter.

CAUTION: Do not weld, braze, solder, or in any way alter any motor component.



CAUTION: Maximum operating pressure must not exceed recommended motor pressure capacity.



CAUTION: Always carefully inspect any system component that may have been struck or damaged during operation or in an accident. Replace any component that is damaged or that is questionable.



CAUTION: Do not force any coupling onto the motor coupling shaft as this could damage the unit internally.



Ross Operation extends close technical cooperation and assistance. If problems occur which you cannot solve, please contact our Ross Technical Service Representative or local Ross Authorized Service Center Distributor. See the back cover of this manual for our address and our phone and fax numbers.



Ross Operation
2745 Snapps Ferry Road
Greeneville, TN 37745
Tel. (423) 639-8151
FAX. (423) 787-2418