

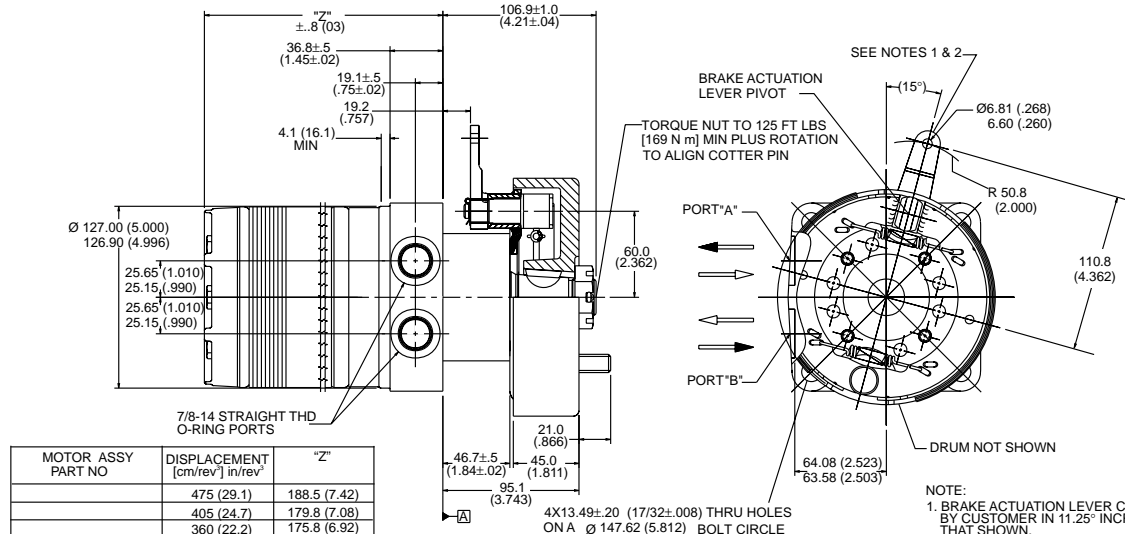

# Another brake/motor package from offers a low cost solution to your mechanical brake requirements.

## Mechanical Brake Motor with Optional Brake Drum



MOTOR ASSY PART NO	DISPLACEMENT [cm <sup>3</sup> /rev] in <sup>3</sup> /rev	"Z"
	475 (29.1)	188.5 (7.42)
	405 (24.7)	179.8 (7.08)
	360 (22.2)	175.8 (6.92)
	280 (17.1)	166.1 (6.54)
	240 (14.5)	161.3 (6.35)
	195 (12.0)	156.7 (6.17)
	170 (10.3)	153.4 (6.04)
	140 (8.6)	150.4 (5.92)
	130 (7.8)	148.6 (5.85)
	100 (6.1)	145.5 (5.73)
	080 (4.9)	145.5 (5.73)

NOTE:  
 DYNAMIC BRAKE HOLDING CAPACITY IS 4500 IN LBS [508 N m] WITH 450 IN LBS [51 N m] OF INPUT TORQUE AT LEVER PIVOT. BRAKE CAPACITIES ARE TYPICAL FOR FULLY BURNISHED BRAKE SHOES. O.E.M. TESTING REQUIRED TO VERIFY ACTUAL FIELD CONDITIONS.

- NOTE:
1. BRAKE ACTUATION LEVER CAN BE POSITIONED BY CUSTOMER IN 11.25° INCREMENTS FROM THAT SHOWN.
  2. BRAKE ACTUATION LEVER IS SHIPPED UNATTACHED.
  3. THE RADIAL LOAD OF UP TO 4000 LBS [1814 kg] MAY BE ALLOWABLE AT A DISTANCE OF 2.75 [69.9] FROM DATUM A. RADIAL LOAD IS CONSIDERED THE VECTOR SUM OF THE RADIAL FORCES ACTING ON THE SHAFT, SUCH AS: CHAIN PULL, GEAR FORCES AND OR WEIGHT ON A DRIVEN WHEEL. SEE SIDELOAD RATING CURVES FOR FURTHER DETAIL. CONTACT YOUR SALES ENGINEER FOR THIS COMPUTATION. ALL DIMENSIONS ARE FOR REFERENCE ONLY. NOTE: 2" BRAKE LEVER SHOWN. ALSO AVAILABLE IN 3.5" LEVER.

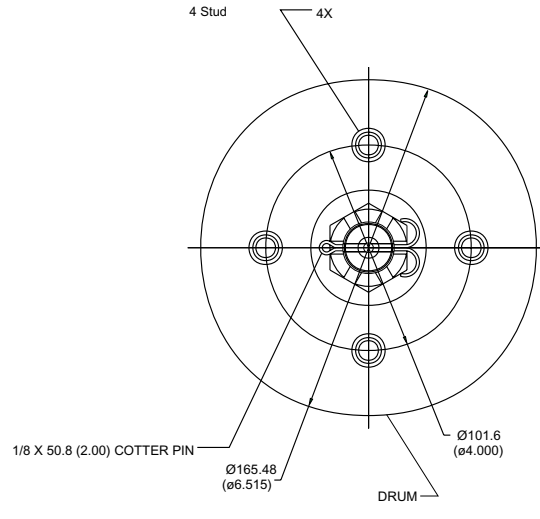
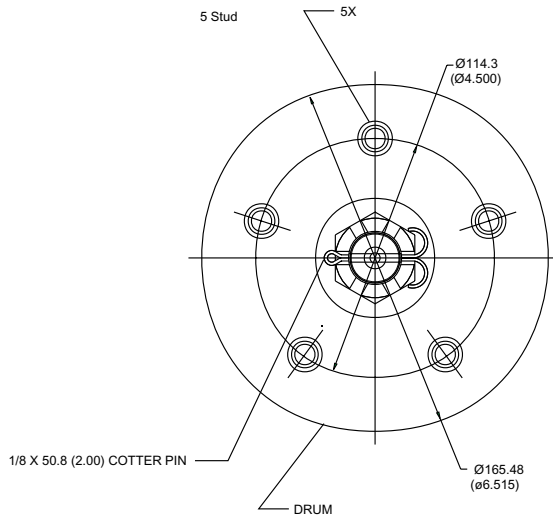

## **You asked for it, and we engineered it!**

The next innovation in brake motor technology from Ross is now ready for OEM manufacturers. As with our previous integrated brake, this new model offers a solution to the size, cost and reliability issues of old braking systems for hydraulic motors.

**This new mechanical brake is the perfect integration of a braking system for hydraulic motors that our customers wanted. Our goal was to create a truly integrated brake motor package perfect for smaller applications with the same reliability as our first brake motor. We did just that.**

This new version offers a cost effective, more compact solution for the turf and agricultural markets. Additionally, front

mounting enables the brake to operate safely even in the unlikely event of a motor failure.

Ross engineers designed the

This mechanically applied version of the brake motor is available in 16 motor displacements (4.9 to 58.5 cu./in.). Pressure capacities are up to 4,000 psi intermittent and 3,000 psi continuous. Flows up to 30 gpm and speed up to 799 rpm are available. Motor output torque up to 12,396 lb. in. intermittent and 9,239 lb. in. continuous is available.

system to provide up to 4,500 lb. in. of holding capacity. A 1.25-inch tapered shaft is standard on all brake motors. The mechanical brake motor is also very compact.

The integrated package reduces both assembly time and product inventory. Our new mechanical brake motor has made assembly

as simple as bolting it on. There is no need to assemble separate components, then perform adjustments and tests. By reducing assembly time and inventory, manufacturers can see lower overall costs. Also, the need to purchase individual components from different suppliers is eliminated.

**Ross's latest integrated motor is truly another innovation the market has been waiting for. The compact size, reliable holding capability and ease of installation makes this new mechanical brake motor the perfect choice for many turf or agricultural applications using hydraulics for wheel motors.**

Bulletin No. 2731-B1/USA

### **Ross Operation**

2745 Snapps Ferry Road  
Greeneville, TN 37744 USA  
Tel: (423) 639-8151  
Fax: (423) 787-2418

