

▼ Shown: PEJ-1401B



- Two-speed operation reduces cycle times for improved productivity
- Powerful .5 hp induction motor is submerged in the oil reservoir to run cooler, protect the motor, simplify the pump interface, save space and reduce noise
- Large 1.5 gallon reservoir allows operation of a wide range of cylinders
- 24 VDC remote pendant control on certain models for safer operation
- Externally adjustable relief valve allows control of operating pressure without opening the pump
- 40-micron internal return line filter keeps oil clean, promoting longer pump life
- Full length side tube for easy monitoring of oil level





◀ The Remote Jog Model of the Submerged Pump simplifies repair on this construction crane.

Best Performance for Mid-Range Cylinders and Tools

▼ SELECTION CHART

For more technical information see next page.

5 BASIC PUMP TYPES	
Select the model that suits your application. For special requirements see page 77 or contact your Enerpac office.	
PED-Series: with Dump Valve <ul style="list-style-type: none"> • Ideal for punching, crimping and cutting • For use when load holding is not required • Control pendant with 10 ft. cord controls valve and motor 	
PEM-Series: with Manual Valve <ul style="list-style-type: none"> • Ideal choice for most applications • Manual valve control, for both single-acting and double-acting applications • Manual motor control 	
PER-Series: with Solenoid Valve <ul style="list-style-type: none"> • Ideal for production and lifting • All valves are 3-position for Advance/Hold/Retract • Control pendant with 10 ft. cord for remote valve operation 	
PEJ-Series: with Remote Jog <ul style="list-style-type: none"> • For light production and lifting applications • Manual valve control for single-acting or double-acting cylinders • Control pendant with 10 ft. cord for remote motor operation 	
PES-Series: with Pressure Switch <ul style="list-style-type: none"> • Designed for maintaining pressure applications, such as clamping, workholding and testing • All versions include manual valves for directional control 	

* Contact Enerpac for details on VM style valves.

Submerged Electric Pumps



Submerged Pump Application

The Submerged pump is best suited to power small to medium size cylinders or hydraulic tools, or whenever a quiet, intermittent duty cycle is needed. With its low sound level and the addition of the optional oil cooler, the Submerged pump is suited to light production work as well.

Its lightweight and compact design also make it ideal for applications which require some transport of the pump.

For further application assistance see the "Yellow Pages" or contact your local Enerpac office.

Page: **104**

PE Series



Reservoir Capacity:

1.5 gal.

Flow at Rated Pressure:

20 in³/min.

Motor Size:

.5 hp

Maximum Operating Pressure:

10,000 psi

Pump Type	Used with Cylinder	Valve Function	Valve Type*	Usable Oil Capacity (gal)	Model Number 115 VAC, 1 ph	Weight (lbs)
	Single-acting	Advance/Retract	Dump	1.5	PED-1001B	55
	Single-acting	Advance/Retract	Manual VMP 10000D	1.5	PEM-1201B	53
	Single-acting	Advance/Hold/Retract	Manual VMF 10000D	1.5	PEM-1301B	53
	Double-acting	Advance/Hold/Retract	Manual VMC 10000D	1.5	PEM-1401B	53
	Single-acting	Advance/Hold/Retract	Solenoid (VEF-15500D)	1.5	PER-1301B	65
	Double-acting	Advance/Hold/Retract	Solenoid (VEC-15600D)	1.5	PER-1401B	65
	Single-acting	Advance/Retract	Manual VMP 10000D	1.5	PEJ-1201B	55
	Single-acting	Advance/Hold/Retract	Manual VMF 10000D	1.5	PEJ-1301B	55
	Double-acting	Advance/Hold/Retract	Manual VMC 10000D	1.5	PEJ-1401B	55
	Single-acting	Advance/Retract	Manual VMP 10000D	1.5	PES-1201B	62
	Double-acting	Advance/Hold/Retract	Manual VMC 10000D	1.5	PES-1401B	62

PE-Series, Submerged Electric Pumps

◀ For full features see page 74.

Submerged Pump Performance							
Motor Size	Pressure Rating		Output Flow Rate**		Motor Electrical Specifications*	Sound Level	Relief Valve Adjustment Range
	(psi)		(in ³ /min)				
	(hp)	1 st stage	2 nd stage	1 st stage			
0.5	1,000	10,000	150	20	13 @ 115-1-50/60 6.75 @ 230-1-50/60	62-70	1,000-10,000

* At bypass and maximum pressure. See matrix footnotes on next page for Hz limitations.

** All flow data at 60 Hz, 50 Hz data will be 5/6 th this number.

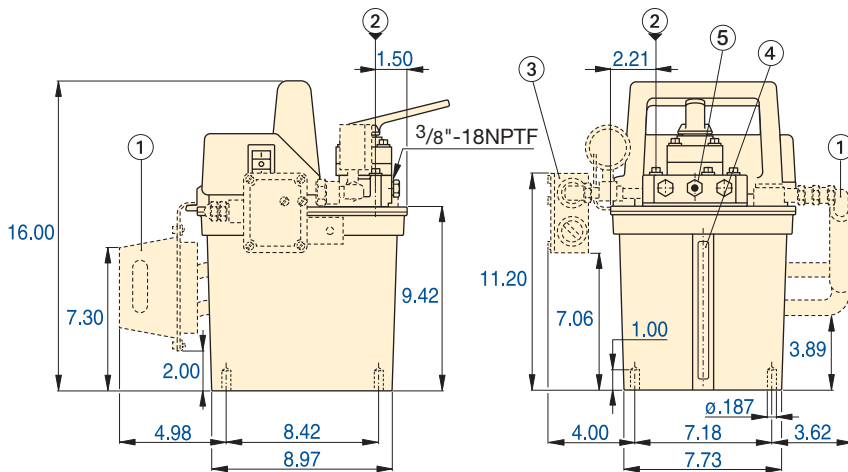
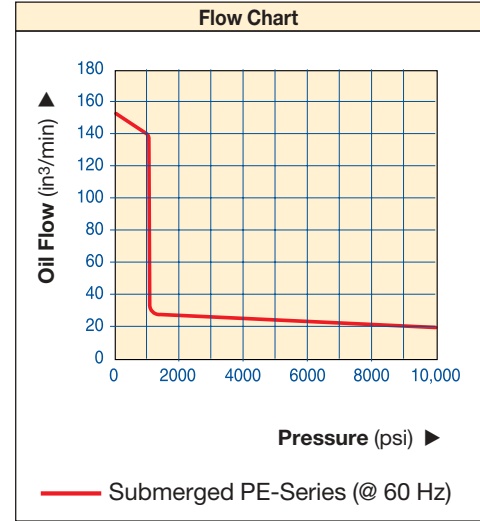

- ① Heat Exchanger (optional for all models)
- ② Fill Port
- ③ Pressure Switch (PES-Series, optional for other models)
- ④ Oil Level Indicator
- ⑤ Adjustable Relief Valve

i **Speed Chart**

To determine how a submerged pump will operate your cylinder, see the Pump/Cylinder Speed Chart in the “Yellow Pages”.

Page: **113**



◀ This PED-1001B Submerged pump quickly and quietly powers a hydraulic nut cutter in this bucket maintenance application.

Submerged Electric Pumps Ordering Matrix

CUSTOM BUILD YOUR SUBMERGED PUMP

If the Submerged Pump that would best fit your application cannot be found in the chart on page 75, you can easily build your custom submerged pump here.

▼ This is how a Submerged Pump Model Number is built up:



1	2	3	4	5	6	7
Product Type	Motor Type	Pump Type	Pump Series	Valve Type	Reservoir Size	Motor Voltage

1 Product Type

P = Pump

2 Motor Type

E = Electric motor

3 Pump Type

D = Dump

J = Jog

M = Manual

R = Remote (Solenoid) ¹⁾²⁾

S = Pressure switch

4 Pump Series

1 = .5 hp, 10,000 psi

5 Valve Type

0 = Dump

2 = 3-way, 2-position, normally open

3 = 3-way, 3-position, tandem center

4 = 4-way, 3-position, tandem center

6 Reservoir Size

01 = 1.5 gallon

7 Motor Voltage and Heat Exchanger

B = 115 V, 1 Ph, 60 Hz ¹⁾

D = 115 V, 1 Ph, 60 Hz ¹⁾
with heat exchanger

E = 230 V, 1 Ph, 50 Hz ²⁾

F = 230 V, 1 Ph, 50 Hz ²⁾
with heat exchanger

I = 230 V, 1 Ph, 60 Hz

¹⁾ Can also run at 50 Hz with manual valve

²⁾ Can also run at 60 Hz with manual valve

Ordering Example

Model Number: PER-1301B

The PER-1301B is a .5 hp, 10,000 psi, submerged electric pump, with 1.5 gallon usable oil capacity, a 3-way, 3-position modular, remote solenoid valve and a 115 V, 1 Phase, 60 Hz motor.

PE Series

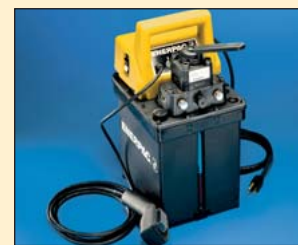

Reservoir Capacity:

1.5 gal.

Flow at Rated Pressure:

20 in³/min.

Motor Size:

.5 hp

Maximum Operating Pressure:

10,000 psi



Hoses

Enerpac offers a complete line of high-quality hydraulic hoses. To ensure the integrity of your system,

specify only genuine Enerpac hydraulic hoses.

Page: **116**



Gauges

Minimize the risk of overloading and ensure long, dependable service from your equipment. Refer to the

System Components section for a full range of gauges.

Page: **122**



The **PER-1301B**, **PER-1401B**, **PER-1301D** and **PER-1401D** include a Modular (solenoid) Valve and pilot operating check.

Page: **132**