

▼ Shown from left to right: VM32, VE33, VM33, VM43L, VE43-115



- Advance/Retract and Advance/Hold/Retract operation of single-acting and double-acting cylinders
- Manual or solenoid operation
- Pump mounting will retrofit on most Enerpac pumps
- Available “locking” option on VM Series valves for load-holding applications
- Standard “locking” feature on VE Series 3-position valves

▼ ZE4420SB-FH Z-Class pump is mounted next to an Enerpac H-frame press, includes VE43 electric valve to control cylinder operation.



For Reliable Control of Single and Double-Acting Cylinders



Valving Help

See Basic System Set-Up and Valve Information in our ‘Yellow Pages’

Page: **114**

Valve Operation	Used with Cylinder	Valve Type	
Manual	Single-acting	3-Way 2 Position	
Manual	Single-acting	3-Way 3 Position, Tandem Center	
Manual	Double-acting	4-Way 3 Position, Tandem Center	
Manual	Single-acting	3-Way 3 Position, Tandem Center, Locking	
Manual	Double-acting	4-Way 3 Position, Tandem Center, Locking	
Solenoid 24 VDC	Single-acting	3-Way 2 Position, Dump	
Solenoid 24 VDC	Single-acting	3-Way, 3 Position, Tandem Center	
Solenoid 115 VAC	Single-acting	3-Way, 3 Position, Tandem Center	
Solenoid 24 VDC	Double-acting	4-Way, 3 Position, Tandem Center	
Solenoid 115 VAC	Double-acting	4-Way, 3 Position, Tandem Center	

For remote valve applications, see page 133.

Pump Mounted Directional Control Valves



About the VM/VE Series

Enerpac's new line of VM and VE series valves include several new features and design improvements over competitive models.

All valves feature several gauge ports for "system", A port and B port pressure monitoring. User adjustable relief valves are included on all models to allow the operator to easily set the optimum working pressure for each application. VM33 and VE43 valves include "System Check" feature, for more precise pressure holding and improved system control. The VM33 has improved porting which provides faster cylinder retraction while motor is running.

All of the features make it easy to see that Enerpac is the only choice for high pressure hydraulic pumps and valves.

VM, VE Series



Flow Capacity:

4.5 gal./min.

Maximum Operating Pressure:

10,000 psi

Model Number	Hydraulic Symbol	Schematic Flowpath			Weight (lbs)
		Advance	Hold	Retract	
VM32					5.6
VM33					6.7
VM43					6.8
VM33L					10.7
VM43L					10.8
VE32D					8.7
VE33					20.3
VE33-115					20.3
VE43					20.3
VE43-115					20.3



Push-Button Control Station

VE33-115 and VE43-115 electric valves are supplied with IC400 control station. These valves include an 8 ft. power cord, and can be used on any Enerpac pump. They require a separate 115 volt power supply to operate.



Locking Valves

For applications that require positive load holding, VM Series valves (except the VM32 valve) are available with a pilot-operated check valve. This option provides hydraulic locking of the load until the valve is shifted into the retract position.

To order this feature, place an "L" at the end of the model number.



Pendants for VE-Series Solenoid Valves

When ordering Enerpac VE-Series solenoid valves, the pendant must be ordered separately for Z-Class pumps. Pendant connection to be plugged into electric box of pump.

To be used with solenoid valves:	Pendant Model Nr.
VE32D	ZCP-1
VE32, VE33	ZCP-3

▼ Shown from left to right: VC-20, VC-4L



VC Series



Flow Capacity:

4.5 gal/min.

Maximum Operating Pressure:

10,000 psi



Locking Valves

For applications that require positive load holding, VC and VM Series valves are available with a pilot-operated check valve. This option provides hydraulic locking of the load until the valve is shifted into the retract position.

- Advance/Hold/Retract operation for use with single-acting or double-acting cylinders

Valve Operation	Valve Type	Model Number	Hydraulic Symbol	Schematic Flowpath			Weight (lbs)
				Advance	Hold	Retract	
Manual	3-Way, 3 Position, Tandem Center	VC-3					6.4
Manual	3-Way, 3 Position, Tandem Center, Locking	VC-3L					10.3
Manual	3-Way, 3 Position, Closed Center	VC-15					6.4
Manual	3-Way, 3 Position, Closed Center, Locking	VC-15L					10.3
Manual	4-Way, 3 Position, Tandem Center	VC-4					6.4
Manual	4-Way, 3 Position, Tandem Center, Locking	VC-4L					10.3
Manual	4-Way, 3 Position, Closed Center	VC-20					6.4
Manual	4-Way, 3 Position, Closed Center, Locking	VC-20L					10.3

Return line kit included with remote valves

Directional Control Valves Dimensions

Valve dimensions in inches

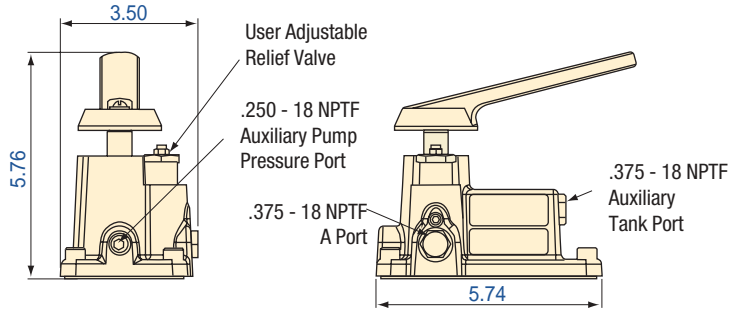

VM32

**VM,
VE
Series**



Flow Capacity:

4.5 gal./min.

Maximum Operating Pressure:

10,000 psi

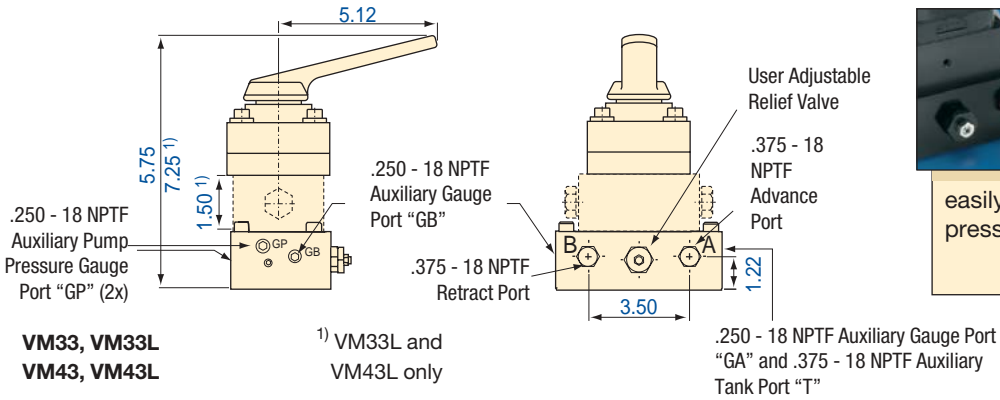

**VM33, VM33L
VM43, VM43L**

¹⁾ VM33L and VM43L only



User Adjustable Relief Valve

All VM- and VE-Series have a user adjustable relief valve to allow the operator to

easily set the optimum working pressure.

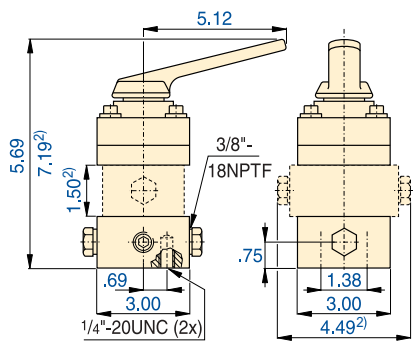

VC-3, VC-3L, VC-15, VC-15LVC-4, VC-4L, VC-20, VC-20L

²⁾ VC-3L, VC-15L, VC-4L and VC-20L only

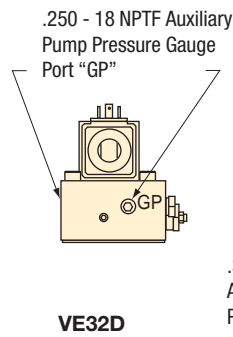

VE32D

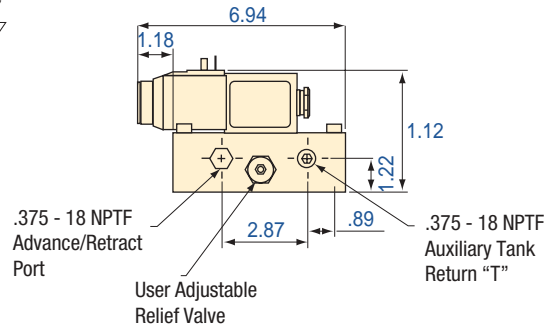

**VE33-115
VE43-115**

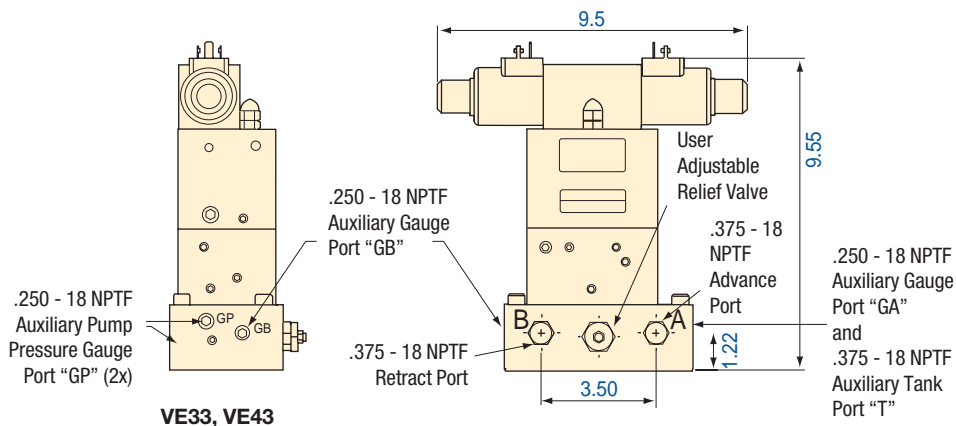

VE33, VE43

