

▼ Shown: EPHR-110



- Patented “Safety Cage” jaw retention system
- High force hydraulic system for effortless pulling of large components
- Slim tapered jaws for better gripping in tight spots
- Available in 2 and 3 jaw design
- More efficient pulling, as one man can do the job where normal pullers often require two operators



◀ An EPHR-116, 50-ton hydraulic Posi Lock® puller easily removes the main drive gear from this metal forming brake press.

## High-Tech Pulling



### Transport and Store

Conveniently store and transport hydraulic pullers and accessories. Order the **EPT-2550** Storage Cart and make your job easier to do!



### Long Jaws

Used to increase the reach and spread of pullers. They maintain the same pulling capacity as the standard jaws, but reduce clamping force to 25%.

Page: 163



Visit the **Products** section of our web site for more information and product selection charts regarding puller sets and individual puller component parts. [www.enerpac.com](http://www.enerpac.com)



### Application Tip

Because of the unique safety cage design, Posi Lock® pullers will grip on surfaces where normal pullers would slip off; e.g. tapered bearings.

Basic Pullers only, cylinder not included.

Number of Jaws	Max. Spread (in)	Capacity (ton)	Model Number*
2	12.00	10	EPH-208
3	12.00		EPH-108
2	15.00	15	EPH-210
3	15.00		EPH-110
2	18.00	25	EPH-213
3	18.00		EPH-113
2	25.00	50	EPH-216
3	25.00		EPH-116

\*Cylinder is not included.

# Posi Lock® Hydraulic Grip Pullers

## ▼ SETS SELECTION CHART

Style	Capacity (ton)	Basic Puller	Cylinder	Stroke (in)	Pump Set	Set Model Number	Weight (lbs)
2 Jaw Puller	10	EPH-208	RC-106	6	-	EPHR208	24
	10	EPH-208	RC-106	6	EP-1	EPHS208	60
	15	EPH-210	RC-1510	10	-	EPHR210	49
	15	EPH-210	RC-1510	10	EP-1	EPHS210	85
	25	EPH-213	RC-2514	14.25	-	EPHR213	98
	25	EPH-213	RC-2514	14.25	EP-1	EPHS213	118
3 Jaw Puller	50	EPH-216	RC-5013	13.25	-	EPHR216	192
	10	EPH-108	RC-106	6	-	EPHR108	26
	10	EPH-108	RC-106	6	EP-1	EPHS108	62
	15	EPH-110	RC-1510	10	-	EPHR110	52
	15	EPH-110	RC-1510	10	EP-1	EPHS110	88
	25	EPH-113	RC-2514	14.25	-	EPHR113	106
	25	EPH-113	RC-2514	14.25	EP-1	EPHS113	126
50	EPH-116	RC-5013	13.25	-	EPHR116	202	

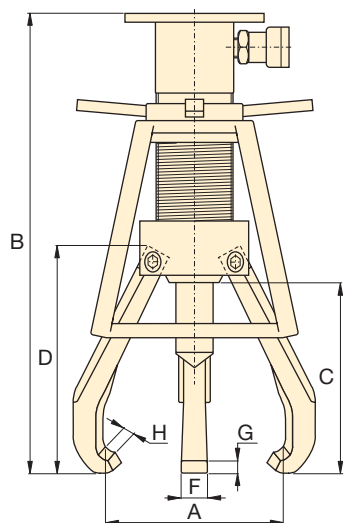

## EPH Series



Capacity:

**10-50 tons**

Maximum Reach:

**8.0-14.0 inches**

Maximum Spread:

**0.75-25.0 inches**

Maximum Operating Pressure:

**10,000 psi**



### Pump Sets

All Posi Lock Hydraulic Puller Sets that include 115 VAC pumps will feature the following components:

	EP-1 Pump Set
Pump	PUJ-1200B
Hose	HC-9210
Gauge	G-2535L

Components for 230 VAC pumps are available on request.



### ▼ \*Optional Accessory

Dimensions (in)							Weight (lbs)	Model Number	Accessories		
Spread Range	Overall Length	Reach (max.)	Jaw Length	Jaw Width	Tip Clearance	Tip Depth			Ram Point Sets	Lift Plates	*Long Jaws
A	B	C	D	F	G	H					
.75-12.0	19.61	8.00	9.34	.88	.29	.27	14	EPH-208	EPH-155	EPH-11052	EPH-11054
.75-12.0	19.61	8.00	9.34	.88	.29	.27	16	EPH-108	EPH-155	EPH-11052	EPH-11054
1.0-15.0	26.19	10.00	10.64	1.00	.441	.36	22	EPH-210	EPH-155	EPH-11052	EPH-11054L
1.0-15.0	26.19	10.00	10.64	1.00	.441	.36	25	EPH-110	EPH-155	EPH-11052	EPH-11054L
2.5-18.0	33.31	12.00	13.72	1.25	.508	.38	47	EPH-213	EPH-257	EPH-11352	EPH-11354L
2.5-18.0	33.31	12.00	13.72	1.25	.508	.38	55	EPH-113	EPH-257	EPH-11352	EPH-11354L
3.0-25.0	36.19	14.00	16.29	1.44	.598	.46	90	EPH-216	EPH-508	EPH-11652	EPH-21654L
3.0-25.0	36.19	14.00	16.29	1.44	.598	.46	100	EPH-116	EPH-508	EPH-11652	EPH-11654L

For full details on puller accessories see page 164.

\*Long Jaws are available as optional accessories.

## ▼ RAM POINT SETS SELECTION CHART

Fits Model Number	EPH-208 EPH-108 EPH-210 EPH-110	EPH-213 EPH-113	EPH-216 EPH-116
			
Set Number	EPH-155	EPH-257	EPH-508
Set Includes	Dia. x Length (in)	Dia. x Length (in)	Dia. x Length (in)
Flat Ram Point	1 x 1	1.5 x 2.25	2 x 3
	1 x 3	2 x 2.25	2.75 x 3
	–	2 x 4	2.75 x 5
Tapered Ram Point	1 x 1.5	1.5 x 2.5	2 x 3.75
	1 x 3.5	2 x 2.5	2 x 3.75
	–	2 x 4.5	2.75 x 5.5
Ram Point Adaptor	–	–	2.75 x 2.25



Always wear Safety Goggles and Gloves while using pullers.



Visit the **Products** section of our web site for more information and product selection charts regarding puller sets and individual puller component parts. [www.enerpac.com](http://www.enerpac.com)



## ▼ LIFT PLATE SELECTION CHART

Fits Puller Set Model Number	Model Number *	Thickness (in)	Diameter (in)
EPH-208	EPH-11052	.25	6
EPH-108	EPH-11052	.25	6
EPH-210	EPH-11052	.25	6
EPH-110	EPH-11052	.25	6
EPH-213	EPH-11352	.38	8
EPH-113	EPH-11352	.38	8
EPH-216	EPH-11652	.38	10
EPH-116	EPH-11652	.38	10



\* Mounting screws included. Lifting plates are standard included with EPH-Series Pullers.

◀ EPH-116 used to remove electric motor pulleys. Puller is positioned using the Lift Plate.

## ▼ LONG JAW SELECTION CHART

Model Number	Fits Models	No. Req.	Spread Dimensions (in)	Reach (in)	Weight (each) (lbs)
EPH-11054	EPH-208	2	2.25 - 15.0	9.7	2.5
	EPH-108	3			
EPH-11054L	EPH-210	2	1.5 - 22.0	15.8	5.5
	EPH-110	3			
EPH-11354L	EPH-213	2	1.5 - 30.0	20.0	10.5
	EPH-113	3			
EPH-21654L	EPH-216	2	2.0 - 38.0	25.0	16.5
EPH-11654L	EPH-116	3			



◀ **EPH-11054L**  
Long Jaws are used for added reach and spread. They have the same load capacity as standard jaws with 25% of the clamping force.